



UIT

THE ARCTIC
UNIVERSITY
OF NORWAY

Department of Electrical Engineering

Electric vehicles and vehicle-to-grid technology

How utilities can play a role

—

Moez Tahir (mta027)

Master's thesis in Electrical Engineering, June 2017



ELECTRIC VEHICLES AND VEHICLE-TO-GRID TECHNOLOGY: HOW
UTILITIES CAN PLAY A ROLE

By

Moez Tahir

A Thesis Submitted to Department of
Electrical Engineering of UiT – The Arctic University of Norway
in Partial Fulfillment of the Requirements for the Degree of

Master of Science

Department of Electrical Engineering
UiT- The Arctic University of Norway
Narvik, Norway

June, 2017

Acknowledgements

I would like to express my deepest gratitude to my thesis supervisor associate professor Bjarte Hoff of the department of Electrical Engineering at UiT – The Arctic University of Norway. The door to Hoff's office was never closed and his guidance along the way was valuable whenever I ran into a trouble spot or had a question about my research or writing. He consistently allowed this thesis to be my own work, but steered me in the right direction whenever he thought I needed it.

June 2017, Narvik, Norway

Moez Tahir

Abstract

Adverse effects of fossil fuel burning internal combustion engine vehicles has alarmed nations worldwide. With recent technological advancements in electric vehicle industry, governments throughout the world are promoting wider adoption of electric vehicles to mitigate environmental issues. However, increasing popularity of electric vehicles will pose a great threat to existing electric grids due to added load of electric vehicles in power systems distribution network. This study provides solution to stabilize electric grid health in the form of two objectives. First, to develop a fast charging station to reduce consumer anxiety problems related to slow charging stations. The charging setup designed in this study caters two issues; one, to charge EV batteries in minimum time and two, provide utilities with active and reactive power support using EV batteries and charging station, respectively. The second objective of this study is to develop smart charging strategy for the benefit of electric utilities and EV owners. The approach adopted in this study to develop smart charging schedule is based on optimization technique to minimize cost of charging for both, electric utilities and EV owners. This will essentially level utility load throughout the day by providing power to charge EV batteries during off-peak hours, and, on the other hand, utilities will take power from EV batteries for peak power shaving during peak power demand hours of the day. The optimization method adopted in this study is particularly quadratic programming to minimize cost of charging.

Contents

Acknowledgements.....	i
Abstract	ii
LIST OF TABLES	viii
LIST OF FIGURES.....	ix
LIST OF NOTATIONS	xii
Abbreviations.....	xii
Variables	xiii
Sets.....	xiv
Parameters.....	xiv
1 Introduction.....	1
1.1 Background	1
1.2 Purpose.....	4
2 Literature Review.....	8
2.1 Electric vehicle technology	8
2.1.1 Power train	9
2.1.2 Energy storage system	11

2.1.3	Charging infrastructure	13
2.2	Impacts of EVs on power system network.....	16
2.2.1	Load profile.....	16
2.2.2	System components	17
2.2.3	Phase unbalance and voltage profile.....	17
2.2.4	Harmonics.....	18
2.2.5	Stability.....	18
2.3	State-of-the-art V2G.....	19
2.4	Utilities and V2G	23
2.4.1	Optimization techniques	24
2.5	Conclusion.....	25
3	Design of V2G Infrastructure	27
3.1	State-of-the-art V2G infrastructure	27
3.2	DC Fast charging station.....	30
3.2.1	Bidirectional AC-DC power converter	30
3.2.2	Bidirectional DC-DC converter	32
3.3	Control mechanism	32
3.3.1	Grid side controller (GSC).....	32
3.3.2	Local controller.....	35
3.4	Method	41

3.4.1	Case study	41
3.4.2	Implementation	41
4	Utility's Role in V2G.....	42
4.1	System model and description	42
4.2	Problem statement	45
4.2.1	Optimization technique.....	46
4.3	Regional load control	47
4.3.1	Objective function.....	48
4.3.2	Constraints	48
4.3.3	Complete optimization problem	50
4.4	Area load control	51
4.4.1	Residential load scheduling	51
4.4.2	Industrial load scheduling.....	53
4.4.3	Commercial load schedule.....	54
4.5	Method	55
4.5.1	Case study	55
4.5.2	Implementation	56
5	Results and Discussion	57
5.1	V2G infrastructure results	57
5.1.1	Case A – V2G infrastructure.....	57

5.1.2	Case B – peak shaving	62
5.2	Optimization results	65
5.2.1	Case C – regional load control.....	66
5.2.2	Case D – residential load scheduling.....	71
5.2.3	Case E – industrial load scheduling.....	74
5.2.4	Case F – commercial load scheduling	77
5.3	Cost analysis.....	80
5.4	Discussion of results.....	81
6	Conclusion and Future Work.....	84
6.1	Conclusion.....	84
6.2	Future work	85
	References.....	87
	Appendix.....	91
A1	Regional load control	91

LIST OF TABLES

Table 2.1 Performance ratings of electric motors [14].	10
Table 2.2 Power density and specific power of electric motors [14].	11
Table 2.3 Comparison of NiMH and Li-ion cell types in EVs [14].	13
Table 2.4 SAE charging standards [19].	15
Table 5.1 TPTL description and simulation parameters [53]	58
Table 5.2 Battery parameters and specifications	60
Table 5.3 Simulation parameters of case study A.	61
Table 5.4 Simulation parameters and specifications.	65
Table 5.5 Parameters and values used in optimization	68
Table 5.6 Parameters used in case study D.	71
Table 5.7 Parameters and values used in case study E	74
Table 5.8 Values and parameters for commercial load scheduling	77
Table 5.9 Cost reduction after smart scheduling strategy.	81

LIST OF FIGURES

Figure 1.1: Optimization models (a) regional load control (b) area load control	6
Figure 2.1: Schematic diagram of BEV power train.....	9
Figure 2.2: Timeline of battery technology development [15].....	12
Figure 2.3: Block diagram of DC fast charging station	14
Figure 2.4: Schematic framework of V2G.....	21
Figure 3.1: An overview of V2G infrastructure.....	29
Figure 3.2: Three-phase three-level AC-DC converter [51].....	31
Figure 3.3: Grid side converter Simulink block diagram [51].....	35
Figure 3.4: Algorithm for local controller	40
Figure 4.1: Regional load profile	47
Figure 4.2: Residential load profile	52
Figure 4.3: Industrial load profile	54
Figure 4.4: Commercial load profile.....	54
Figure 5.1: User signal.....	59
Figure 5.2: Utility reference signal	59
Figure 5.3: Utility demand signal	60
Figure 5.4: EV battery status after simulation	61
Figure 5.5: Power provided to utilities	61

Figure 5.6: Utility demand signal after V2G	62
Figure 5.7: Load profile of building	63
Figure 5.8: Collective SOC of EV batteries.....	63
Figure 5.9: Power stats of EV batteries involved in V2B.....	64
Figure 5.10: Data after V2B simulation.....	64
Figure 5.11: Utility load profile	66
Figure 5.12: Collective state of charge of EVs in different areas of region	69
Figure 5.13: Collective charging currents in different areas of region	69
Figure 5.14: Collective charging powers of different areas in region	70
Figure 5.15: Optimization results of regional load control.....	70
Figure 5.16: Collective SOC of EVs in residential area	72
Figure 5.17: Collective charging current of EVs in residential area.....	72
Figure 5.18: Collective charging power of EVs in residential area.....	73
Figure 5.19: Optimization results of residential load scheduling	73
Figure 5.20: Collective SOC of EVs in industrial area.....	75
Figure 5.21: Collective charging current of EVs in industrial area	75
Figure 5.22: Collective charging power of EVs in industrial area	76
Figure 5.23: Optimization result of industrial load scheduling	76
Figure 5.24: Collective SOC of EVs in commercial area.....	78
Figure 5.25: Collective current of EVs in commercial area	78

Figure 5.26: Collective charging power of EVs in commercial area..... 79

Figure 5.27: Optimization results of commercial load scheduling 79

LIST OF NOTATIONS

Abbreviations

R&D	research and development	EMI	electromagnetic interference
GHG	greenhouse gas	GSC	grid side controller
CO ₂	carbon dioxide	VSI	voltage source inverter
DER	distributed energy resource	VSC	voltage source converter
DES	distributed energy source	PLL	phase lock loop
DR	demand response	PWM	pulse width modulation
ESS	energy storage system	PI	proportional integrator
DC	direct current	Off-peak	low power demand
AC	alternating current		
EV	electric vehicle		
HEV	hybrid electric vehicle		
PHEV	plug-in hybrid electric vehicle		
PEV	plug-in electric vehicle		
BEV	battery electric vehicle		
ICEV	internal combustion engine vehicle		
G2V	grid-to-vehicle		
V2G	vehicle-to-grid		
V2H	vehicle-to-house		
V2B	vehicle-to-building		
V2V	vehicle-to-vehicle		
(dis)charging	charging and/or discharging		
SOC	state of charge		
IPM	interior permanent magnet		
THD	total harmonic distortion		
PV	photovoltaic		
ILP	integer linear programming		
AC-DC	alternating current to direct current		
TPTL	three-phase three-level		

Variables

T_s	sample time	$P_{threshold}$	active power threshold
V_{dc}	direct current voltage	Q_{demand}	reactive power demand
i_d	direct axis current	$Q_{reference}$	reactive power reference
i_q	quadrature axis current	$Q_{required}$	required reactive power
v_d	direct axis voltage	\mathbf{A}	identity matrix
v_q	quadrature axis voltage	\mathbf{B}	battery capacity vector
v_{sa}	phase-a voltage	I	current
v_{sb}	phase-b voltage	P_{grid}	grid power
v_{sc}	phase-c voltage	$P_{load\ profile}$	power demand profile
P	active power (real power)	$P_{charging}$	charging/discharging power
Q	reactive power	\mathbf{x}	state vector
i_d^*	direct axis reference current	\mathbf{x}^T	state vector transpose
i_q^*	quadrature axis reference current	\mathbf{H}	weight matrix
P_{ref}	active power reference	\mathbf{f}	weight vector
Q_{ref}	reactive power reference	\mathbf{l}_b	lower bound vector
k_{ip}	controller gain	\mathbf{u}_b	upper bound vector
k_{iq}	controller gain		
k_{pd}	proportional constant		
k_{pq}	proportional constant		
d_q	quadratic axis duty ratio		
d_d	direct axis duty ratio		
D_a	phase-a axis duty ratio		
D_b	phase-b axis duty ratio		
D_c	phase-c axis duty ratio		
U	user input		
P_{demand}	active power demand		
P_{load}	active power load		

Sets

U	set of aggregated vehicles, index $i = 0, 1, 2, \dots$
T	set of time intervals, index $t = 1, 2, 3, \dots$

Parameters

P_t	utility power in time interval t
$p_t^{residential}$	residential power demand in time interval t
$p_t^{industrial}$	industrial power demand in time interval t
$p_t^{commercial}$	commercial power demand in time interval t
$I_{i,t}^c$	charging and/or discharging current of i^{th} vehicle in interval t
$I_{i,t-1}^c$	charging and/or discharging current of i^{th} vehicle in interval $t-1$
$I_i^{c,min}$	maximum discharging current of i^{th} vehicle
$I_i^{c,max}$	maximum charging current of i^{th} vehicle
b_i	battery capacity of i^{th} vehicle
$S_{i,t}$	state of charge of i^{th} vehicle in time interval t
$S_{i,t-1}$	state of charge of i^{th} vehicle in time interval $t-1$
S^{min}	minimum allowed state of charge
S^{max}	maximum allowed state of charge
S_i^{min}	minimum allowed state of charge of i^{th} vehicle
S_i^{max}	maximum allowed state of charge of i^{th} vehicle
$S_{i,t}^{desired}$	desired state of charge of i^{th} vehicle in time interval t

$t^{desired}$	desired time interval
$C_{i,t}$	charging and/or discharging power of i^{th} vehicle in interval t
C_i^{min}	maximum discharging power of i^{th} vehicle
C_i^{max}	maximum charging power of i^{th} vehicle

1 Introduction

Concerns about growing fossil fuel consumption have been circulating in research and development (R&D) community since late 1900s. Increased consumption of fossil fuels is causing environmental hazards, such as, greenhouse gas (GHG) emission and energy independence. This has lead governments throughout the world to come up with policies to address these issues. Transportation sector contributes to a large amount of CO₂ in the atmosphere. Recently, electrification of transportation sector has caught attention worldwide as potential and promising solution for aforementioned problems. Many countries in Europe have decided and started to implement a policy of electrification of on surface transportation system in near future. Among these countries, despite its small population, Norway is one of the biggest consumer of electric vehicles in the world. According to Fred Lambert, Editor in Chief and main writer of electrek, Norway has reached a tipping point for electric vehicles as Norway's market share in electric vehicles reaches record breaking 37% [1]. This increasing trend of 'road electrification' calls for effective fast charging stations to avoid customer anxiety and smart charging strategies for utilities and owners of electric cars to benefit from it.

1.1 Background

Pollution caused by combustion engines besides the depletion of fossil fuel reserves has caught attention of research community ever since 1900s. Many solutions have been studied and experimented with in the past to address this issue. However, recent advances in technology associated with batteries and power electronics have enabled researchers to shift their focus, in recent decades, to introduction, planning and implementation of electric vehicles (EVs) [2]. Electrification of transportation sector, or as they call it '*road electrification*', promises to address the environmental issues, as we all, allows electric utilities to minimize consumer costs.

Electric vehicles (EVs) have gained an immense popularity in recent years and this trend seems to keep growing in near future until the day most of transportation sector is comprised of EVs, as per the new policies initiated by several governments worldwide [3]. Electrification of transportation sector appears to be a feasible solution to reduce GHG emission caused by combustion engines, as well as, electric utilities to improve power quality by employing EV batteries as distributed energy resource (DER).

As the trend of EVs on road grows rapidly, it creates new challenges to facilitate its development. Implementation of fast charging stations to avoid customer anxiety and increased load on electric grid are among the most important challenges. To address these problems and facilitate development in order to utilize this increasing trend towards the betterment of electric utilities and EV owners does not only require development in technical areas but also needs strategies in regulatory and management systems to enable an effective integration of EVs with electric grid [4].

In the past, research was mostly carried out in the area of grid-to-vehicle (G2V), unidirectional, flow of power. However, Vehicle-to-grid (V2G) is the latest attraction in field of EVs and their integration with electric grid. According to this phenomenon, bidirectional flow of electric power is taken into consideration, that is, power can be taken from grid to charge EV batteries during off-peak hours and power can be provided to grid during peak hours from EV batteries to reduce utility load.

A big portion of vehicles are expected to be parked during most part of the day. This idea can be used to facilitate V2G technology. During these idle times, plugged-in EVs can be used to support bidirectional power flow between utilities and EV batteries. These plugged-in EVs can provide ancillary services for utilities, such as, peak shaving, power quality improvement, and frequency and voltage regulation [5]. Various studies have been carried out in this area and different algorithms have been proposed for demand response (DR) management. S. Shao, M. Pipattanasomporn, and S. Rahman propose DR algorithm with user choice [6]. M. Pipattanasomporn, M. Kuzlu, and S. Rahman, propose a home energy management solution with DR analysis [7]. M. Ansari, A. T. Al-Awami, E. Sortomme, and M. A. Abido, propose a

coordinated bidding strategy using fuzzy logic for the ancillary services provided with V2G operation [8].

As the number of EVs has increased manifolds in northern Europe, due to incentive and green policies, potential realization of V2G seems practical in the region. EVs can be considered as distributed energy sources (DES) which can further enhance renewable energy integration in this region. In this scenario, batteries of EVs are taken as added energy storage systems(ESS). According to Hedegaard, Ravn, Juul, and Meibom's article, "*effects of electric vehicles on power systems in Northern Europe*", there is an increased investment in wind power in Northern Europe due to increased number of EVs integrated in power system network [9].

At the present moment, there are charging stations available for EVs but they allow unidirectional power flow, that is, from grid to vehicle to charge EV batteries. With increasing number of EVs throughout the world, the realization of V2G technology seems feasible. However, to implement V2G technology effectively there is a need of efficient bidirectional charging stations, as charging equipment plays a vital role in V2G development. There are different modes of charging that are researched and implemented [10], but to avoid consumer rage and anxiety as EV market expands, direct current (DC) fast charging stations appear to be most efficient solution.

The second challenge with V2G realization, as EV fleet increases manifolds in near future, is charging and discharging strategies. To fully tap into full potential of V2G, as well as, to avoid unwanted and adverse effects on electric grid, utilities are bound to devise smart charging and discharging strategies [4]. Once these two critical issues, efficient bidirectional charging stations and smart (dis)charging strategies, are resolved, utilities and EV owners can benefit from advantages of V2G technology. Some of the aspects of smart integration of EVs into grid include, load leveling, peak shaving, valley filling and minimizing utility costs and simultaneously minimizing charging costs for EV users.

Another factor that is important in V2G realization is the presence of a new entity in energy market referred to as aggregator in V2G application [4]. Aggregator serves as an intermediary between utility and EVs. The tasks related to control and management of EV (dis)charging schedule along with responsibility of coordination of electric market participation of EVs in an electric power distribution network are handled by this entity, called aggregator. Finding cost effective charging

schemes in a given area is also expected to be one of the main roles of aggregators as V2G makes sense in aggregated scenarios, that is, large fleet of EVs is integrated in power system network for added energy storage [4].

As mentioned before, smart charging strategies builds the core foundation of V2G implementation in energy market. In recent years, charging strategies has tugged the interest of many researchers and engineers in electric power field. Many algorithms, models and solutions have been proposed for smart charging strategies that are economically beneficial for EV owners and electric utilities. One method to find an optimal charging schedule is to formulate a mathematical optimization problem with design and other constraints. This method, helps to achieve most cost-effective strategy for (dis)charging schedule [4].

Yifeng He, Bala Venkatesh and Ling Guan present an optimization model based on global optimal scheduling solution and distributed scheduling solution in order to minimize total cost [11]. Another optimization model is presented by Kevin Mets, Tom Verschueren, Filip De Turck, Chris Develder, where they achieve peak shaving and reduce variability of household load by integrating EV battery (dis)charging schedule [12]. Finally, a comparison is done by Kevin Mets, Reinhilde D'hulst, Chris Develder between three different (dis)charging scheduling techniques using quadratic programming. They have introduced two methods, one based on a classical optimization approach using quadratic programming, and second based on market based coordination, a multi-agent system which uses bidding on virtual market to achieve an equilibrium price that satisfies demand and supply [13]. However, after analysis, quadratic programming optimization appears to be most promising solution to minimize total cost of (dis)charging schedule.

1.2 Purpose

Due to increasing market of EVs in transportation sector, the motivation to investigate potential solutions for EV (dis)charging forms the foundation of this study. There are two main objectives of this study, first, to build a working bidirectional fast charging station for EVs to profit from vehicle-to-grid (V2G) application. Second, to develop a programming problem for aggregator, in order to find optimal charging scheme which benefits EV owners and electric utilities.

The first objective expands over a MATLAB simulation model of complete bidirectional fast charging station which is integrated with electric utility/grid. The charging station supports two-way flow of electric power between EVs and utilities and is based on DC fast charging mode. The simulation model includes grid side converter, EV side control, EV battery, a local controller acting as aggregator and a utility block. The overall model is studied and implemented to charge EV battery when users desire. It also provides active power from EV battery and reactive power from grid side converter to utility/grid for peak shaving, valley filling and load leveling. In addition, EV owners' will to participate in V2G is given the highest priority, that is, when EV owners want to charge it is not allowed for aggregator to take power from EV batteries.

Second objective of this study is to formulate a centralized optimization model based on quadratic programming. This optimization model minimizes overall grid power and manages smart (dis)charging schedule for aggregator. The outcome of optimization is to participate in V2G by providing maximum power for charging EV batteries when electric power is available to satisfy EV owners' demand, as well as, provide power from EV batteries to utility for peak shaving, load leveling and valley filling profiting both EV owners and electric utilities.

In this study, the basic optimization strategy is centralized, that is, aggregator is responsible for charging and discharging schedules based on some forecasts available. However, there are two models proposed in this study for optimization. One model optimizes overall regional utility power. This model takes into account all EVs available and connected in all sectors; industrial, residential and commercial. In simple terms, first model optimizes overall utility power under one control. The second model is based on area-wise distributed load of utility. In this model, each aggregator optimizes load of a given area in utility's distribution network based on number of EVs connected in that particular area. For instance, EVs in residential area will participate in load management of residential area. Similarly, EVs in commercial and industrial areas participate in power optimization of their respective areas. This model, takes three optimization controls for three different major areas in a distribution network of utility and optimizes overall grid power by leveling load in each area separately. The two models for optimization are presented, in Figure 1.1(a) and 1.1(b) respectively, for better understanding of the concept.

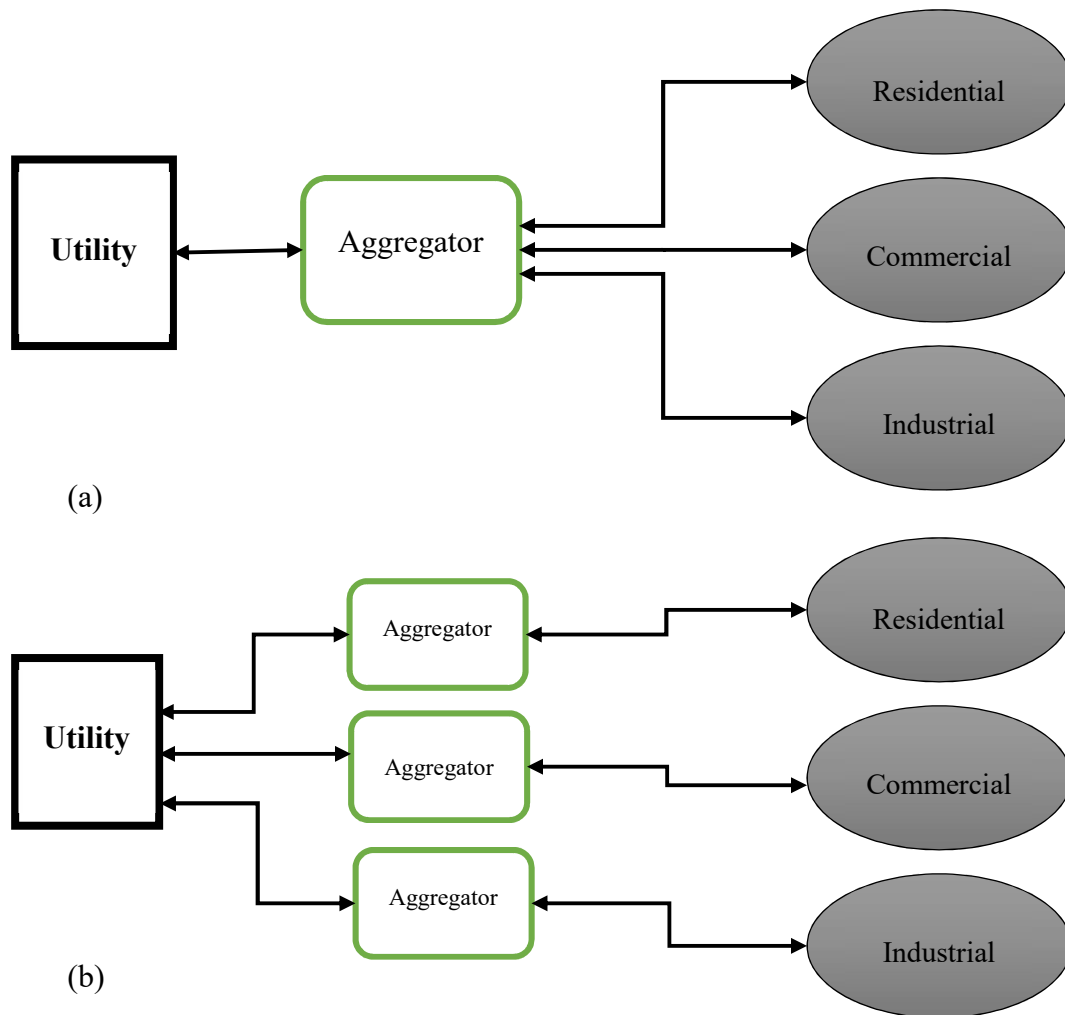

Figure 1.1: Optimization models (a) regional load control (b) area load control

For this study, it is assumed that all EVs available in an area are participating in V2G, that is, charging and discharging for best economic measures provided by aggregator. Secondly, the aggregator responsible for EV interaction with utility is in place. It can control and manage charging and discharging of EVs with respect to consumers' requirements. It is also assumed that, necessary communication between EVs and aggregator are present and running the system smoothly.

To sum it up, the purpose of this study can be briefed as a complete system for V2G application, which can participate in charging and discharging schedules without technical barriers, and with

minimum cost of charging for EV owners and electric utilities. The study will conclude how utilities role in V2G scenario can improve electric grid conditions in today's growing EV market.

2 Literature Review

Considerable share of electric vehicles (EVs) in automotive market and growing concerns regarding hazardous pollutants in environment, have tugged the interest of research and development centers worldwide. Concurrently, expanded integration of EVs with electric grid raises concerns regarding electric grid health due to added load. Utilities will need to install smart systems to manage this extra load without causing problems on generation and distribution level. However, the recent advances in EV technology have encouraged electric utilities to participate in EV market, where EVs can provide ancillary services for electric utilities. Although, the idea of utility involvement is in its early stages practically, the potential of using growing number of EVs to facilitate electric utilities is encouraging. This concept is known as vehicle to grid (V2G) technology. Utilities can participate by providing power to EV batteries during off-peak hours and take power from EV batteries during peak load hours. To implement this idea, utilities will have to devise smart charging strategies for peak shaving, valley filling and load leveling which in turn will improve overall grid conditions. This chapter of study presents a review on EV technologies, impact of EVs on power system network, state of the art V2G and how utilities can play their role in this concept.

2.1 Electric vehicle technology

Electric vehicles (EVs) have gone through a tremendous technological development in recent decades. The continuous development in EV technology is vital to compete with existing internal combustion engine vehicles (ICEVs). As a result of series of technological advances, EVs have taken over a considerable share of automotive market throughout the world. This huge market share has been promoted by offering different incentives by many governments worldwide to overcome greenhouse gas (GHG) emission. For instance, in Norway there are tax certain tax

exemptions in addition to free parking for EVs in several areas, which lead to a tipping point of 37% market share of EVs in Norway [1].

As EV market expands, continuous research and development is required for large scale penetration of EVs in future [14]. There are different types of EVs available in market, such as, hybrid electric vehicle (HEV), plug-in hybrid electric vehicle (PHEV), plug-in electric vehicle (PEV) and battery electric vehicle (BEV). However, for this study, most effective and efficient EVs are plug-in electric vehicles (PEVs) which operate entirely on battery power, that is, battery electric vehicles (BEVs). BEVs have higher battery capacity resulting in higher range and support with electric grid integration, for V2G application. The main areas of focus in EV development are power train, energy storage system (ESS) and charging infrastructure for future V2G scenarios [15].

2.1.1 Power train

Power train is a series of mechanism which provides drive from engine of automotive to axle. As mentioned previously, BEVs operate exclusively on battery power and propel through electric motor. Therefore, power train of BEVs constitute of battery, electric motor and transmission. Power train of a basic BEV is shown in Figure 2.1.

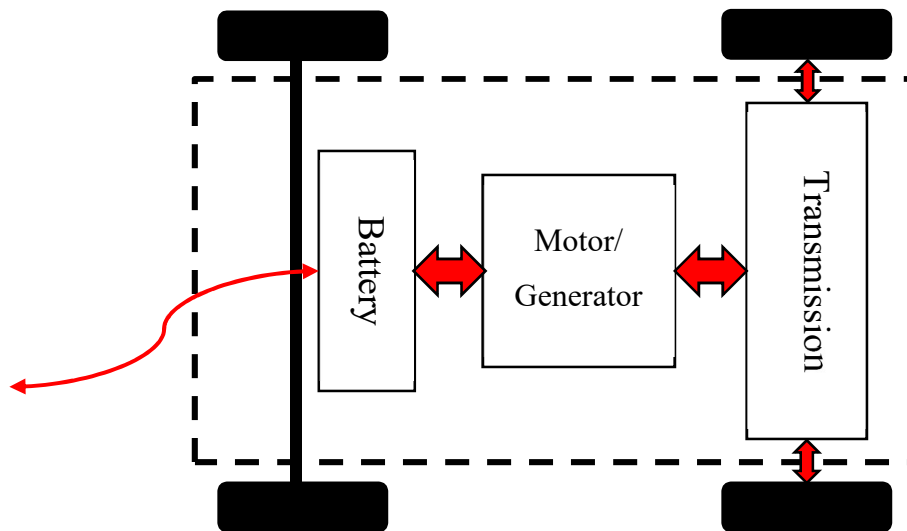

Figure 2.1: Schematic diagram of BEV power train

BEVs can be charged with external power source, that is, power from electric grid and regenerative braking [16]. In this study, only external charging is considered for charging EV batteries, that is, there is no generation for battery charging through regenerative braking in model used for this study.

There are several motor technologies that are used in different EVs. However, most of automobile industry producing EVs and hybrid electric vehicles (HEVs) use interior permanent magnet (IPM) machines [14]. Performance ratings of electric motors for some EVs available in market are given in Table 2.1, whereas, Table 2.2 gives an overview of specific power and power density of IPM used in EVs and HEVs.

Table 2.1 Performance ratings of electric motors [14].

Parameter	2004 Prius	2006 Accord	2007 Camry	2008 LS600h	2010 Prius	2011 Sonata	2012 Leaf	2014 Accord	Chevy Volt
Peak power[kW]	50	12.4	70	110	60	30	80	124	111
Peak torque[NM]	400	136	270	300	207	205	280	N/A	368
Rotational speed[r/min]	6,000	6,000	14,000	10,230	13,500	6,000	10,400	N/A	N/A
Cooling	Heat sink with water/glycol loop	Air-cooled heat sink	Heat sink with water/glycol loop	Double sided, water/glycol loop	Direct cooled, single side water/glycol loop	Heat sink with water/glycol loop	Heat sink with water/glycol loop	N/A	N/A

Table 2.2 Power density and specific power of electric motors [14].

Parameter	2004 Prius	2006 Accord	2007 Camry	2008 LS600h	2010 Prius	2011 Sonata	2012 Leaf
Peak power density [kW/L]	3.3	1.5	5.9	6.6	4.8	3.0	4.2
Peak specific power [kW/kg]	1.1	0.5	1.7	2.5	1.6	1.1	1.4
Magnet mass [kg]	1.232	N/A	0.928	1.349	0.768	N/A	1.895

2.1.2 Energy storage system

The most important and core component of BEV is its energy storage system (ESS), that is, battery. Battery is the sole propulsion source in BEVs and at present, it is one of most expensive component in BEV technology. There are some restraints in battery technology, which has been a major hindrance in wider EV adoption in transportation sector. The key elements that attract EV users are range, acceleration, and cost [15]. These specifications are directly, or indirectly, dependent on battery technology of EVs.

Energy density [Whr/L]/specific energy [Whr/kg], and volume of battery affect range and acceleration of EVs [14]. However, low energy density is a major factor that influences range of all electric drive vehicles. Besides, volume of battery pack also plays a key role since, there is a limited space available in EVs for battery packs. Therefore, utilizing same space for a higher capacity battery pack holds a significant value in EV technology. There are some concerns regarding safety features and life cycle as well. Although there are limitations regarding battery technology, it is still in its early stages of development and it does embrace potential to mature in future with higher energy, lower cost and compact size [15].

The present durable, safe, cost effective and higher energy batteries have flourished as a result of series of development over past decades. From lead-acid (Pb-acid) batteries in previous

generations to current lithium-ion (Li-ion) battery, battery technology has gone through tremendous development. Figure 2.2 shows a timeline of technical improvements in the field of battery technology.

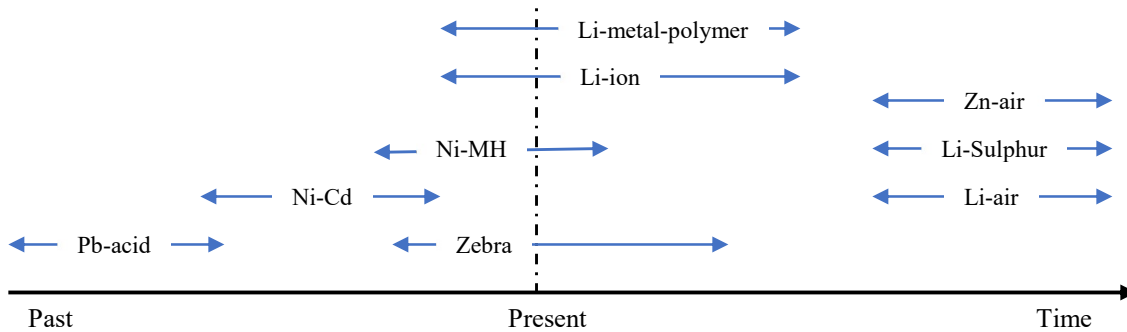

Figure 2.2: Timeline of battery technology development [15]

After continuous research and experiments, most feasible batteries used in EV technology available in market are nickel-metal-hydride (NiMH) batteries and lithium-ion (Li-ion) batteries. Although NiMH batteries were used until recent past, introduction of Li-ion batteries have put EV technology in a new era of long range and more powerful EVs to compete with traditional ICEVs [15].

Most of major EV manufacturers in present market use Li-ion batteries because of its long range, higher energy density, low cost and non-toxic behavior. However, most important feature of Li-ion batteries is acceptance of fast charge [15]. This feature holds a high value for consumers as it combats anxiety of charging EVs over long periods. Nissan Leaf, Mitsubishi i-MiEV, Tesla Model S and Chevrolet Volt are among the top choices of EV users and they all come with Li-ion battery as energy storage system. Table 2.3 compares cell types of NiMH and Li-ion batteries used in BEVs.

Given the advantages of Li-ion batteries, there are some drawbacks of Li-ion batteries as well. The most noteworthy drawback is, battery malfunction can lead to fire risk and explosion [17]. This technology is not fully mature but it definitely promises to be a perfect battery solution for future EVs [15].

Table 2.3 Comparison of NiMH and Li-ion cell types in EVs [14].

	NiMH BEV	Li-ion Plug-in Hybrid EVs - BEVs
Nominal cell voltage [V]	1.2	3.3-3.8
Energy density [Wh/l]	250	200-400
Specific Energy [Wh/kg]	100	120-200
Power density [W/l]	500-800	800-2200
Specific power [W/kg]	200-400	500-1200

2.1.3 Charging infrastructure

BEVs are charged through an external source, that is, from electric grid. BEV battery is charged from grid using a charger. Charger is rather necessary for charging BEV battery as power supplied by grid is in alternating current (AC) form and the battery is in direct current (DC) form. Charger is designed in order to rectify AC power level from electric grid to appropriate DC power level for charging BEV battery.

Typical EV charger is constructed using an AC-DC converter, or rectifier, for necessary conversion. For fast charging stations, an additional DC-DC converter is added in design for better energy conversion. Chargers can be installed either on-board or off-board depending on configuration and charging level.

On-board chargers have particular design specifications. They need to be compact and light weight for efficient EV propulsion. However, on-board chargers have a drawback of low power rating and they are usually employed for slow charging levels. On the other hand, off-board chargers are installed on dedicated locations as they are rather bulky because of added DC-DC converter for fast charging inside charger [15].

In addition to charger design, there are some set standards accepted internationally regarding EV charging. These include society of automotive engineers (SAE), international electromechanical commission (IEC) and CHAdeMO EV standards [18]. Table 2.4 shows SAE charging levels with reference to SAE electric vehicle conductive charge coupler standard [19].

However, for wider spread of EVs, it is necessary that consumer anxiety related to charging time is minimized as much as possible. For this purpose, DC fast charging topology for charging stations is most effective and efficient solution, since, they only take couple of minutes to charge the battery as compared to AC charging topologies. Typically, DC fast charging stations are designed to supply, as much as, 50 kW power for charging EV battery [20]. For such design, the unit becomes bulky. At the same time, EV performance is highly depended on weight. Therefore, it is appropriate to have these charging stations off-board and on dedicated locations. A general block diagram of a DC fast charging station is shown in Figure 2.3.

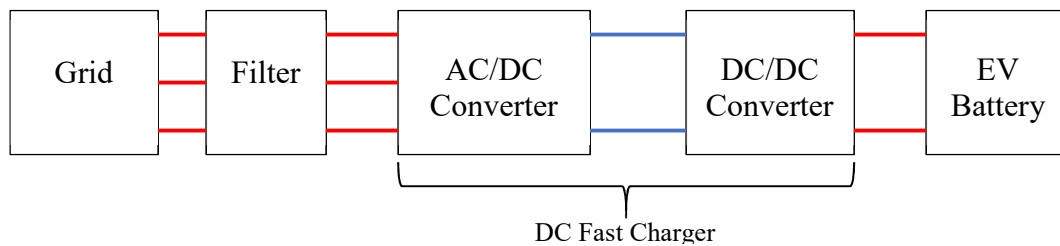

Figure 2.3: Block diagram of DC fast charging station

It can be seen from Table 2.4 that; DC fast charging systems allow consumers to charge in less than 1 hour to approximately 10 minutes of charging time. Currently, there are two configurations proposed for DC fast charging system based on direction of power flow, that is, from grid to vehicle and vice versa.

The first configuration is known as unidirectional DC fast charger. This configuration only allows the charger to draw power from grid to charge EV batteries. The advantage of this configuration is that it doesn't deteriorate battery life since, number of cycles are limited [21]. The disadvantage is that, unidirectional chargers can't participate in V2G systems, that is, power can't flow from EV battery to grid. Conversely, bidirectional DC fast chargers allows the operation of power flow in

both directions. It operates on two modes, charge and discharge. This is helpful for implementing V2G system and benefit from wider EV spread. However, this configuration affects battery life because of large number of cycles [21].

Table 2.4 SAE charging standards [19].

Charging level	Charge rating	Charge time	Remark
AC level 1	120 V, 1.4 kW (12 A) 120 V, 1.9 kW (16 A)	PHEV: 7 h (SOC–0% to full) BEV: 17 h (SOC–20% to full)	On-board charger
AC level 2	240 V, up to 19.2 kW (80 A)	For 3.3 kW charger: PHEV: 3 h (SOC–0% to full) BEV: 7 h (SOC–20% to full) For 7 kW charger: PHEV: 1.5 h (SOC–0% to full) BEV: 3.5 h (SOC–20% to full) For 20 kW charger: PHEV: 22 min (SOC–0% to full) BEV: 1.2 h (SOC–20% to full)	On-board charger
AC level 3	> 20 kW, single phase and three-phase	To be determined	To be determined
DC level 1	200–450 V _{DC} , up to 36 kW (80 A)	For 20 kW charger: PHEV: 22 min (SOC–0% to 80%) BEV: 1.2 h (SOC–20% to full)	Off-board charger
DC level 2	200–450 V _{DC} , up to 90 kW (200 A)	For 45 kW charger: PHEV: 10 min (SOC–0 to 80%) BEV: 20 min (SOC–20 to 80%)	Off-board charger
DC level 3	200–600 V _{DC} , up to 240 kW (400 A)	For 45 kW charger: BEV (only): <10 min (SOC–0 to 80%)	Off-board charger

2.2 Impacts of EVs on power system network

Along with many advantages that EV development holds, there are some raised concerns regarding electric grid conditions due to wider spread of EV market in future. Integrating large fleet of EVs into power system network for charging EV batteries, negative impacts on electric grid and utilities are inevitable. These impacts must be considered in design and application of V2G system. The impacts concerning electric grid due to large number of EVs in distribution network include voltage drop, phase unbalance, power demand, harmonics, overloading and stability of power system network [15]. This section of literature highlights potential threats to utilities and electric grid due to large number of EVs integrated with electric grid.

2.2.1 Load profile

Integration of EVs in power distribution network adds an additional load on electric grid. The supply of power is a set criteria based on demand. When EVs are connected with grid for charging batteries, it has an extra demand that electric utilities must supply to consumers. If EVs are charged without any planning, that is, uncontrolled charging, EV owners can charge EV batteries any time of the day as their mood dictates. This has a potential threat of increasing load on peak load hours. Increased peak power require more generation to satisfy demand, which can be likely problem for electric utilities.

There are several studies presented in area of increased peak load due to uncontrolled EV charging, in present and future scenarios. Claire Weiller describes in article, “Plug-in hybrid electric vehicle impacts on hourly electricity demand in the United States”, impacts of EV charging on hourly load profile of United States of America (USA) [22]. Similarly, impacts of EV charging on German grid are presented in, “Impact of different utilization scenarios of electric vehicles on the German grid in 2030”, as Germany takes a huge step of electrifying most on road transportation in near future [23]. According to this study, load will be doubled if EV charging is not controlled.

The results of major studies show that, without any management and planning of charging schedules, additional load due to large EV fleet integrated with electric grid will compromise grid reliability.

2.2.2 System components

System components in a power distribution network are designed and implemented as per some set criteria. These criteria are determined using demand and supply of electric power. Adding large numbers of EV in distribution network calls for additional demand from generation side. This additional power is supplied using same system components in distribution network. Overloading of existing system components can easily occur because they are not designed to carry this extra power for EV charging.

Investigations have been carried out by several personnel in field regarding impacts of EV charging on overhead distribution [15]. For instance, in [24], analysis is done on impacts of EV charging on distribution network. It concludes that, increased penetration of EVs has negative influence on transformer lifespan.

It can be said that, without proper network planning and load management strategies for future wider spread of EVs overloading of components in distribution network is unavoidable.

2.2.3 Phase unbalance and voltage profile

As described previously, there are several charging levels available for EV charging. Single phase AC charging originates phase unbalance in electric grid [15]. In addition to phase unbalance, it is also suspected that higher integration of EVs in electric grid will cause voltage drop and voltage deviation in interconnection points of EV charger [15]. However, Csaba Farkas, Gergely Szűcs and László Prikler have concluded in their study that voltage drop in entire network, due to EV charging, is within acceptable limits [25]. Similarly, in [26], it is determined that EV charging has a slight impact in loading of components and doesn't violate voltage limits.

There are many other studies presented on voltage drop and deviation since EV technology came into being. Some studies predict significant impacts while other predict that impacts are rather insignificant. The difference in conclusions is expected because of different system configuration and operation factors which influence results.

2.2.4 Harmonics

Charger plays a vital role in EV systems, as it has been established before. The composition of EV charging stations include power electronics. During operation, switching in power electronics of EV charging system can cause negative impacts on power quality of electric grid due to the generated harmonics [15].

The paper on, “Residential harmonic loads and EV charging”, concludes that voltage total harmonic distortion (THD) caused by EV charging process is less than 1%, which means harmonics injected will not affect power quality [27]. [28] also supports this idea, using Monte-carlo based simulation based method for simulation, that impacts on electric grid due to harmonics during EV charging are acceptable. However, "Harmonic distortion mitigation for electric vehicle fast charging systems", shows that if fast charging is employed for EV charging, the harmonics injected into electric grid are significant.

Again, different outcomes of different studies are because of several factors that influence the study. Nevertheless, the solutions are available to compensate for harmonics injected. For example, filtering devices.

2.2.5 Stability

Stability of power system is defined as, “*the quality of electric grid to bring back operation into steady state after a disturbance*” [15]. Stability holds a high value in reliability of power supplied by electric grid. EVs are relatively new load for electric grids and stability concerns have alarmed many researchers to investigate the impact of EV charging on power system stability.

"Grid interactions and stability analysis of distribution power network with high penetration of plug-in hybrid electric vehicles" presents that, larger penetration of EVs into electric grids, overall system becomes more vulnerable to disturbances and it takes longer time to return to steady state [30]. This is further supported by [31], which states that characteristics of EV charging systems involve absorption of reactive power and injection of current harmonics.

On the contrary, Diyun Wu, K. T. Chau and Chunhua Liu in their research on "Transient Stability Analysis of SMES for Smart Grid with Vehicle-to-Grid Operation" show that EV integration can rather increase stability of power grid, if managed [32].

It can be concluded from above literature on impacts of EV charging on electric grid that, unidirectional power flow in EV charging, that is, direction of power from electric grid to EV batteries, can cause major issues within electric grid and power system networks. However, if planned properly and implemented, V2G system, that is, bidirectional power flow, can mitigate these problems and can enhance power quality of electric grid. Therefore, with increasing market of EVs, realization of vehicle-to-grid technology is not just an advantage but rather necessity of future stable power distribution and operation.

2.3 State-of-the-art V2G

Advances in smart grid technology have matured enough to allow more opportunities to deploy new applications in electric grid. Among all improvements, smart grids have encouraged electric utilities around the world to work towards and realize benefits of integrating electric vehicles with smart grids.

The integration of EVs with smart grids have gone through tremendous development. Previously, only unidirectional power flow, that is from electric grid to EV batteries, was researched and experimented. The reason behind this was that, realization of unidirectional power flow didn't cost a lot in terms of development because of existing standard EV chargers with added communication [33]. The idea was to manage load using load shifting control. Meaning, electric vehicles were charged during off-peak hours. More services from EV batteries required more advanced equipment, such as, bidirectional chargers.

However, recently bidirectional power flow between EV batteries and electric grid have gained popularity. The concept is known as vehicle-to-grid (V2G) technology. Using this concept power can be exchanged between electric vehicles and electric grids. EVs charge during off-peak hours and provide power during peak load hours. In addition, more opportunities were realized with bidirectional V2G which encouraged the industry and electric utilities to promote V2G concept. Figure 2.4 shows a schematic framework for V2G technology. V2G can be categorized into different types depending on mode of employment. For instance, vehicle-to-home (V2H), vehicle-to-vehicle (V2V), vehicle-to-building (V2B) and vehicle-to-grid (V2G). All these types utilize EV battery power to support power network. In V2H, battery of EVs are used to supply power for a home during peak hours and similarly for any other building/area this concept is applied to compensate peak power demands. Among all, V2G has widest scale of opportunities as it supports grid power and in turn, stabilizes power demand for distribution network.

Despite benefits of realization two-way power flow in V2G, smart strategies are required to benefit from this technology. Seen from grid perspective, it has been mentioned before that EVs are an additional load on electric grid besides daily power demand. The planning of EV charging schedule is vital to disperse load in a manner that it doesn't add extra load on electric grids during peak-load hours and minimize negative impacts. Therefore, EV charging must be strategized to achieve gains like, peak shaving and valley filling. The charging control is therefore known as ordered or controlled charging [34].

There are two major methods of realizing V2G control, which are the heart of most studies and research carried in this area. First method is known as centralized controlled. In centralized controlled, collective energy of EVs available in a region are scheduled/controlled to charge and discharge depending on electric grids' demand. There are management strategies applied by electric utilities using aggregator in this method to achieve peak shaving and valley filling. Second method is known as distributed control. In distributed control, there is no central controller to manage charging and discharging of EV batteries [34]. Instead, EV owners build their own charging profile based on their will and demand. There are merits and demerits to both methods. However, in this study the method employed is centralized control for charging. It allows optimal charging schedule in contrast to decentralized charging control where only part of EV information is available which makes charging schedule suboptimal [35].

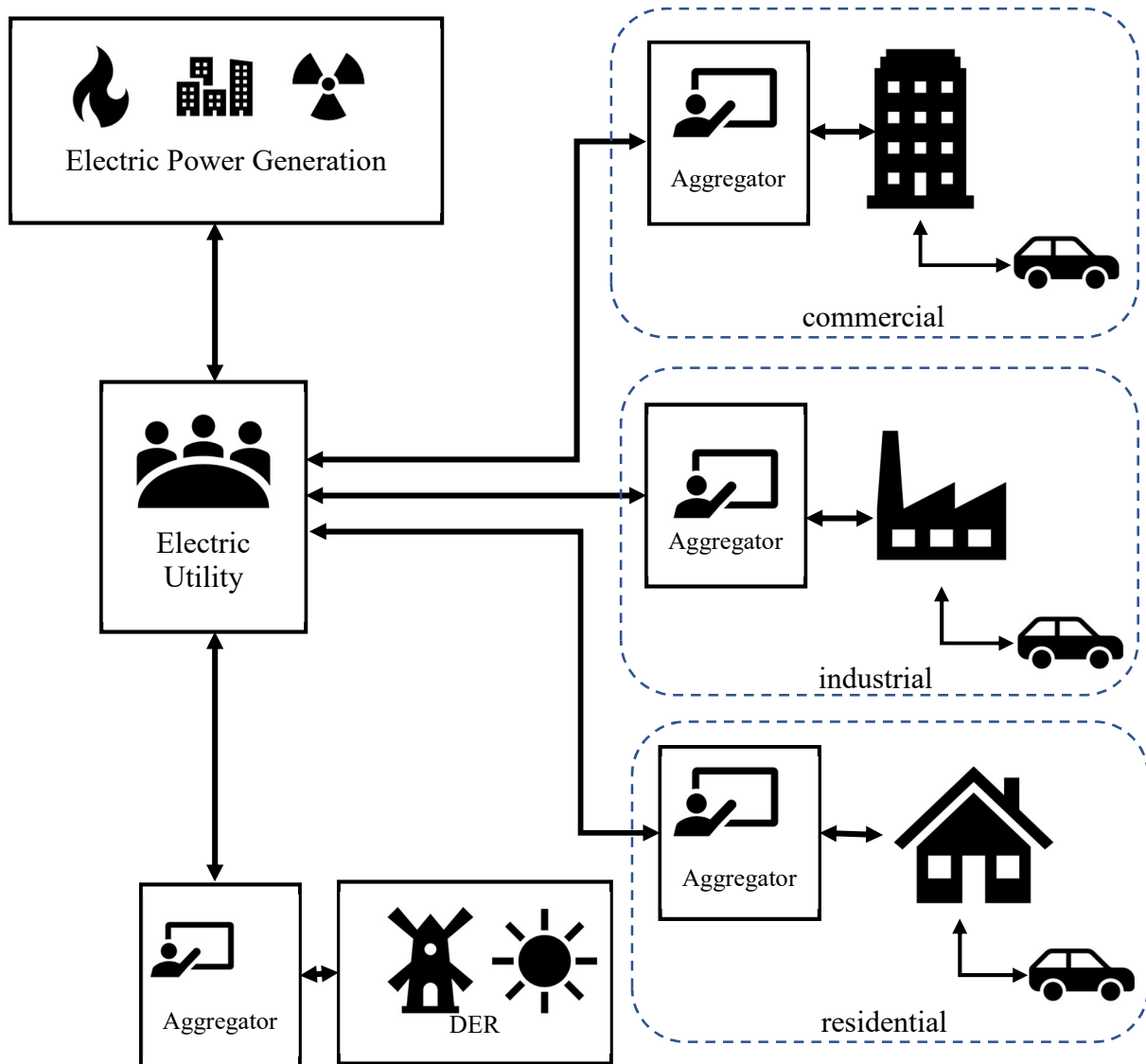

Figure 2.4: Schematic framework of V2G

Once the control method is decided, next phase of planning and managing EV charging and discharging schedule takes place. The most effective way is by using appropriate optimization algorithms for charging schedule. It allows electric vehicles to participate in a wide range of services that can be provided to electric utilities in exchange for incentives given to EV owners for services. Of course, type of service offered by an optimization model is dependent on predefined objective function of optimization technique deployed [35]. Some of the services EVs can provide to electric utilities are briefed in this section.

- *Spinning reserve*: spinning reserve is additional power available to increase the capacity of power generation units. This power is supplied to electric grid in hours of need. V2G serve as spinning reserve service in this scenario. The energy stored in grid connected EVs provide additional generation capacity and can compensate for generation outage [33]. Generation units always have backup generation capacity in case of outage or fault. V2G technology has the potential to support failure recovery and minimize backup generation capacity [33] and reduce cost for utilities.
- *Peak load shaving and load leveling*: it is common observation in distribution network that industrial, commercial, and residential loads have only a short span of peak power demand. For energy efficiency, economic benefits, avoiding electric grid overloading and aging, it is highly desirable to reduce this peak power demand and level load. V2G technology can provide stored energy in EV batteries to electric grid during peak load hours and charge EV batteries during off-peak hours. This technique will reduce peak load on electric grid and level load achieving desirable results [36].
- *Voltage regulation*: voltage regulation and power efficiency are vital factors that need to be regulated for electric grid operation and reliability. The conventional method to achieve voltage regulation is through static volt-ampere reactive compensator [37]. However, with V2G technology, voltage regulation and power correction can be achieved using bidirectional chargers for EVs. DC-link capacitor in charger has the ability to provide reactive power through appropriate switching control [38]. This phenomenon can achieve reactive power support for electric grid.
- *Harmonics*: there are many non-linear power loads connected with modern electric grids. These non-linear loads inject current harmonics into electric grid compromising power quality. EV chargers are also among non-linear loads that inject harmonics into electric grid. However, with appropriate control of EV chargers, they can be used as an active filter to filter out harmonics generated by EV chargers and other non-linear loads connected with grid [39].
- *Support for renewable energy resources*: integration of renewable energy resources with electric grid is limited by energy storage systems available. This causes intermittency issue within renewable energy resources connected with electric grid. When energy generation from renewable resources is more than required or can be stored, additional energy is

wasted because of limited capacity. V2G can solve the intermittency issue of renewable energy sources. EVs can be charged when there is excess generation by renewable energy resources and discharged when renewable energy resources do not generate enough power [40]. Since, V2G can solve energy storage problem, more renewable energy resources can be integrated in electric grids reducing environmental threats and achieving a sustainable power system [15].

2.4 Utilities and V2G

V2G technology has many promising benefits that can improve power quality and improve overall electric grid health. As mentioned earlier, the said prospects of V2G utilization for betterment highly rely on charging and discharging schedules. This is where electric utilities play their role. If utilities can manage EV loads using rate incentives or direct signals, EVs can provide a smooth load curve for utilities, in addition to reliability and frequency regulation [41]. Again, this is exceedingly dependent on smart charging strategies provided by utilities.

Since, EV market has been growing rapidly over the span of last few years, realization of V2G technology has become more feasible. However, with increasing trend of EVs on road, complexity of providing power to charge EV batteries without causing negative impacts on electric grid and problems for electric utilities has caught a great deal of attention. There are many strategies proposed to this date, however because of margin in improvement there is still a lot of focus on producing even better smart charging schedules.

Finding smart charging schedule is vital to implementation of V2G in practical world. Among many studies proposed so far, some of them are beyond the scope and strategy adopted for this study. This section of literature review surveys different approaches taken by researchers to provide a solution for scheduling problem. The survey of studies has helped to formulate a problem definition and mathematical model to solve scheduling problem, which is later discussed in this study.

Among all the strategies, the most common method adopted worldwide to solve (dis)charging problem is through optimization models. This study also uses optimization techniques to provide

a better solution according to requirements of utility, as well as, EV owners. The advantage of using optimization technique is that it uses mathematical formation of problem, which provides most cost-effective solution for optimal charging schedule [4].

2.4.1 Optimization techniques

Several optimization techniques have been used to verify an effective and cost-efficient method of charging and discharging EVs. Some studies focus on user perspective, some studies focus on electric grid point of view and some studies focus on creating a model that can provide a particular service using V2G technology. At the moment, most efficient strategy is a model that is suitable and advantageous for both electric grid, correlating electric utilities, and EV owners.

Alexandros-Michail Koufakis, Emmanouil S. Rigas and Nick Bassiliades in their study on “Towards an optimal EV charging scheduling scheme with V2G and V2V energy transfer” propose a scheme for optimal EV charging control [42]. Their schemes efficiently utilize energy and satisfy customer demands in a scenario where only energy source is electric grid using real-life data from Belgian photovoltaic (PV) panels. In this model, mixed integer programming is used to optimally schedule EV charging in three different cases: (i) no extra energy from electric grid, (ii) additional energy from electric grid and (iii) additional energy from battery pack storage and electric grid [42].

A scheme based on autonomous scheduled charging is proposed in [43]. This model integrates both renewable energy resources and EVs with distribution network, where both sources are treated as distributed energy sources. Considering driving patterns, this study aims to mitigate adverse effects on electric grid due to EV charging by utilizing control signals from aggregator for energy and global power management.

[44] presents a study on optimally charging and discharging EVs according to adaptable scheduling schemes. This study proposes a scheme for charging/feedback of EVs based on either parking mode or mobile mode. Mobile mode focuses on minimizing delay in charging. Whereas, parking mode minimizes charging cost and peak-to-average ratio of grid power. The model is then verified using data from electric load profile of a city in China. However, focus of this study is on

residential electric appliances' demand and supply and integer linear programming (ILP) is used to solve scheduling problem.

Recently, a study has verified that if V2G is applied to a medium building scenario, using a coordinated scheme 14.3% in energy cost reduction is expected in a predetermined building load profile [45]. This model integrates photovoltaic generation and battery energy storage system in the charging station of a medium sized building. Number of EVs visiting charging station is known and the problem is then reduced to ILP for optimization. With vehicle-to-building (V2B) scenario, this study focuses on providing load distribution and demand response services using basic V2G technique, which in this case is referred as V2B.

Dongqi Liu, Yaonan Wang and Yongpeng Shen study and analyze a dynamic optimal scheduling algorithm for EV charging and discharging integrated with wind-thermal system [46]. The system uses multi-objective particle swarm optimization and fuzzy decision-making algorithm to implement an optimal (dis)charging schedule of EVs. The algorithm aims to minimize global cost of grid operation, CO₂ productions, wind restriction, and EV users. The model also promises to equalize demand and supply of active power, as per grid conditions.

Furthermore, [47] studies a charging schedule using heuristic algorithms for active and reactive power support using V2G technology. The studies that were found relevant according to method and strategy adopted in this study are presented in [12] and [13]. These studies focus on achieving a target curve based on quadratic optimization technique. This concept is similar to the one used to derive problem definition and mathematical model of (dis)charging schedule for utilities, in order to achieve peak shaving and load leveling.

2.5 Conclusion

The literature provided in this chapter has helped to form a thorough understanding of latest trends in technology that have emerged over last years of research and development in electric vehicle industry. The literature has provided an insight on present and future requirements regarding fast charging infrastructure to satisfy EV users, in order to promote wider adoption of EVs for utilities' advantage. It has also provided a review of difficulties and challenges that arise from integrating

EVs into distribution network without an appropriate management system and what is required of utilities to mitigate these adverse effects and turn them into positive impacts, that is, deployment of smart charging schedules. From the foundation that has been developed about techniques and technology through this literature, next chapters of this study form a working model of fast charging station for integrating EVs into electric grid and also propose a potential optimization model for smart EV (dis)charging schedule, which can benefit electric utilities and EV owners.

3 Design of V2G Infrastructure

Recently, there is an increased trend of electric vehicle (EV) adoption all over the world. Due to this increasing market, vehicle-to-grid technology has gained wide attention worldwide. There is significant research available on integration of electric vehicles into power systems network. However, advances in technology has enabled researchers to work towards integration of EVs into distribution network for various advantages, especially power system stability and reliability. One noteworthy positive aspect of V2G is that, EVs can be treated as a specific electricity load, meaning they can be used as a mobile storage device to participate load adjustment in electric grid and to provide a platform for renewable energy sources coordination [34]. In this chapter of study, a successful V2G model is created which yields bidirectional power flow between EVs and electric grid/utility. The developed model in this part of study also specifies that penetration of V2G, in fact, establishes an opportunity for implementing smart power distribution through offering two-way communication, and injecting reactive and active power back into electric grid [48].

3.1 State-of-the-art V2G infrastructure

The actual operational efficiency of current power grid is unsatisfying due to high cost and heavy energy waste, which is brought by daily load demand fluctuations and regulation of voltage and frequency from power grid [49]. When demand of energy surpasses capacity of base power plant, peak load power plant must be put in operation to compensate for this demand, concurrently, when power demand is less than produced power, this extra power is wasted [34]. In addition, the control and regulation of voltage and frequency due to this fluctuating load demand adds significant digits to operational cost of power plants [34]. The concept of vehicle to grid (V2G) technology can resolve these problems and serve beneficially for both, EV owners and power companies. The main idea is to use batteries of electric vehicles (EVs) as an intermediate source. During peak

hours, most EVs are idle as per statistical analysis. The stored energy of idle vehicles, and AC-DC converter, can be used to level load demand of power grid by injecting active and reactive power back to grid. During off-peak hours, when load demand is low, owners of EVs can take power from grid to charge their EV batteries. This is a beneficial technology for both consumers and power system operators because not only consumers will pay less to charge during off-peak hours, they will also earn money for supplying power to grid during high demand hours. As for power grids, they don't have to spend extra operational costs for running additional power plants to supply extra power during high demand hours, that is, if V2G technology is implemented successfully.

The implementation of this model requires a charging station or setup where EVs are plugged in, be it a residential charger or a public space with chargers. Charging station provides power to EV batteries from power grid when required, or according to EV owner's needs. on the other hand, when load demand is high these chargers in station provide power back to electric grid. Hence, a bidirectional power flow model.

The wider adoption of EVs require a charging setup where consumers don't have to face anxiety regarding charging periods. A charging station with ability to charge EV batteries in minimum time is vital to the whole phenomenon. The general idea is to use chargers to store energy just like fuel is filled in conventional ICEVs. This study proposes a charging station strategy to charge EVs using DC fast charging technology. DC fast chargers have the ability to charge EV batteries in smallest time interval possible, approximately as minimum as 15 minutes.

DC fast charging station includes an additional DC-DC converter for efficient energy conversion. Due to this added DC-DC converter, charger becomes bulky and can compromise EV performance. To eradicate this issue, DC fast charging stations are installed off-board and on dedicated sites. A general block diagram of DC fast charging station is presented in previous chapter, in Figure 2.3.

Charging stations are vital to V2G technology. However, in addition to charging station topology, control mechanism for converters used in charging station are also very important to control charging and discharging of EVs. The two control mechanisms discussed and implemented in this study are grid side controller (GSC) and local controller. The grid side controller controls the operation of AC-DC converter connected with electric grid and local controller serves as the

aggregator in V2G scenario. Local controller controls the operation of DC-DC converter as per signals received from EV users and electric utilities. Local controller allows EV owners to charge EV batteries whenever they desire, simultaneously, it receives signals from electric utilities to adjust charging schedule to level load and contribute to electric utilities' smooth operation.

In summary, the state-of-the-art model of V2G infrastructure created and implemented in this study include grid connected AC-DC converter, controlled current source acting as DC-DC converter, GSC, local controller and signals from utilities. Each element of said model is further discussed in detail, explaining design and modelling, in coming sections of this chapter. An overview of V2G model created in this study is presented in Figure 3.1.

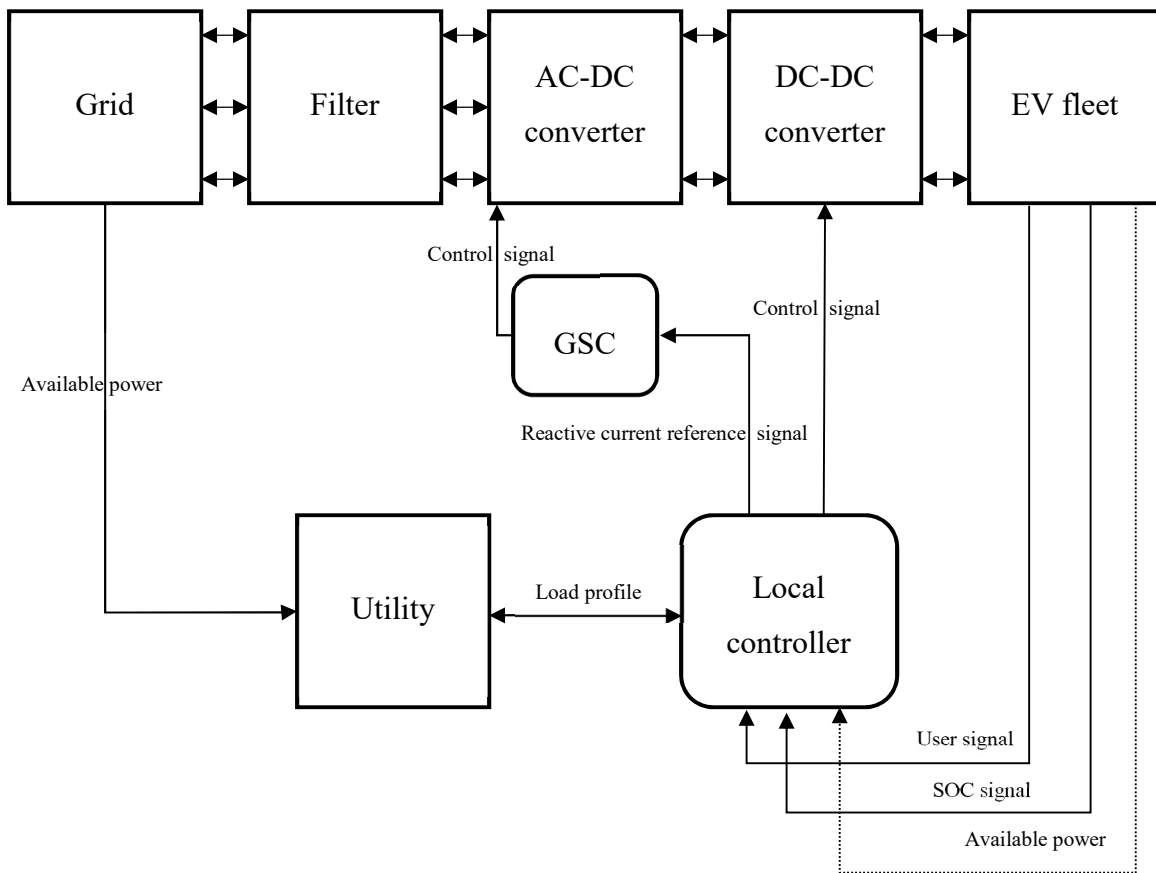

Figure 3.1: An overview of V2G infrastructure

3.2 DC Fast charging station

Charging stations provide energy to EV batteries from electric grid in the form of high voltage AC or DC. There are different topologies available for charging stations, such as, level 1, level 2 and level 3 chargers. This study focuses on off-board EV charging setup, which means conversion of high voltage AC into DC and conversion of high voltage DC to low voltage DC is done in charging station and charger. This method results in fast charging of battery and saves cost, instead of implementing on-board power converters for each EV.

Off-board fast charging stations are a key factor in increasing trend of EV adoption. Off-board chargers extend time/miles that an EV uses with battery power, which helps customers overcome range anxiety for PEVs [50]. The new advances in battery technology has enabled them to accept fast charge, resulting in a faster charging time as compared to older technologies. At DC fast charging stations, AC voltage is converted into DC voltage off the vehicle, and vehicle is DC coupled with charging station [50].

As established, charging station play a vital role in V2G technology. The conversion of currents and direction of flow of power is determined in charging station. The main elements of charging station are two power converters, namely AC-DC and DC-DC converter. The converters perform conversion tasks and determine amount of power and direction of power flow, that is, to be delivered to EV battery or taken from it based on some set standards and algorithm implemented in control strategy. However, in this study a different approach is taken for second phase of conversion. Controlled current source is used instead of DC-DC converter, because it provides same results with additional ability to integrate local controller.

3.2.1 Bidirectional AC-DC power converter

The first stage in off-board EV charging is conversion of high voltage AC to DC for battery charging. AC-DC converters can be implemented both for unidirectional flow and bidirectional flow. Due to requirements of V2G, two-way flow of power in this study, bidirectional three-phase three-level AC-DC converter is explored and implemented for EV charging and discharging.

Among different three-phase AC-DC conversion options, three-phase bidirectional multilevel converters are recommended for high-power charger systems despite supplementary complexity of control circuitry and additional components [51]. These converters are characterized by a high level of power quality at AC input mains with reduced total harmonic distortion (THD), higher power factor, reduced electromagnetic interference (EMI) noise, and additionally provide a ripple-free regulated DC output voltage insensitive to both supply and load disturbances [51]. Additional advantages of this type of converters include, lower switch voltage stress and utilization of smaller passive devices, such as capacitors and inductors [51]. These advantages make three-level bidirectional AC-DC converters more suitable for EV charging station application.

The bidirectional AC-DC power converter is the main link between electric grid and EVs. In charging mode, this converter acts as rectifier to convert high voltage AC from utility to DC bus voltage. In discharging mode, V2G mode, this converter acts as an inverter and inverts DC voltage back into AC to be fed back to electric grid. Based on diode clamped scheme, three-phase three-level (TPTL) voltage source inverter (VSI) is used and modelled in order to reduce total harmonic distortion (THD) of inverter mode [51]. Figure 3.2 shows the circuit diagram of TPTL AC-DC converter used for modeling in this study. Filter connected with grid can overcome current harmonics injected due to switching. The neutral point in TPTL also allows voltage formation besides positive and negative DC bus voltages. For this reason, all power semiconductor switching devices face only half of line voltage; which reduce power switching losses approximately by a factor of two [51].

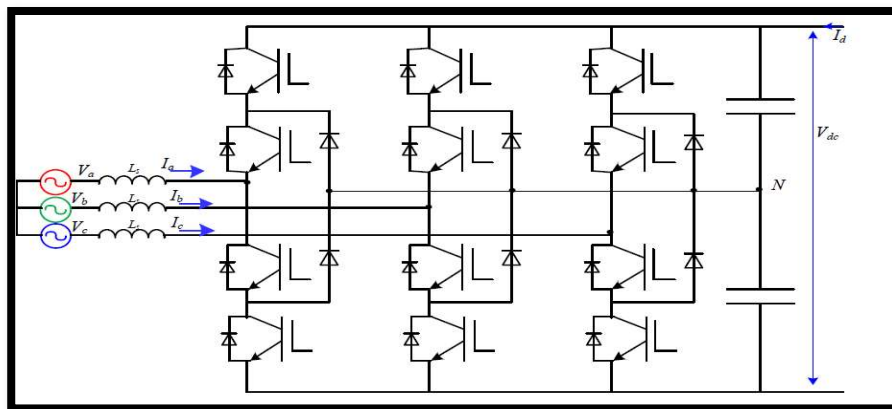

Figure 3.2: Three-phase three-level AC-DC converter [51]

3.2.2 Bidirectional DC-DC converter

The second link between power grid and EVs after AC-DC converter is a bidirectional DC-DC converter which performs both operations, buck conversion, and boost conversion. DC voltage obtained at the output of bidirectional AC-DC converter is higher for charging EV battery and must be converted into a lower value. Similarly, when EV is supplying power to utilities, voltage at battery terminal is lower than the output of AC-DC converter, and again it must be converted to a higher value for high voltage DC-AC inversion. For this purpose, a bidirectional DC-DC converter is required between AC-DC converter and EV battery.

3.3 Control mechanism

Two control strategies employed in this study to implement V2G technology regulate power flow between EV batteries and electric grid. One controller is dedicated to switching control of AC-DC converter to provide active power for charging EVs and supply reactive power to grid. The second controller is a local controller to control power flow between EV batteries and grid.

3.3.1 Grid side controller (GSC)

There are two objectives of grid side controller. First, to provide surplus power for charging EV batteries. Second, to provide reactive power support whenever utilities request. The block diagram of Simulink GSC used in this study is shown in Figure 3.3. It can be seen from figure that, GSC consist of V_{dc} regulator, current regulator and phase lock loop (PLL) & measurements [51]. Regulator uses I_d and I_q (reactive current) reference currents for calculating and setting voltage reference. For power flow from grid to EV battery, I_q reference current is always set to zero. However, if utility requests reactive power support, in V2G mode of operation, reactive current reference is allotted a specific value depending on reactive power demand. In addition, PLL is added in modeling for synchronization with grid and measurements block is added for current and voltage measurements [51].

GSC can supply grid with reactive power support by injecting reactive power at common coupling point. Reactive power controller produces reference q-axis current. However, common coupling point voltage controller generates reference q-axis current [51]. The reactive power support can be requested by utility at any time and GSC should respond immediately by adjusting q-axis current. The reference signal for reactive power support is generated by local controller and sent to GSC to supply reactive power support for utility.

The technique implemented in this study for control scheme of GSC is derived from the study in [51]. This technique uses direct-quadrature-zero transformation equations, active and reactive power calculations and PLL algorithm to maintain utility grid voltage synchronization. Using the Park transformation technique, phase currents and utility voltages are converted from a-b-c coordinate system to d-q coordinate system. In addition, ωt is achieved from PLL. The equations used for d-q transformation are given below.

$$\begin{bmatrix} v_d \\ v_q \end{bmatrix} = \sqrt{\frac{2}{3}} \begin{bmatrix} \sin(\omega t) & \sin\left(\omega t - \frac{2\pi}{3}\right) & \sin\left(\omega t + \frac{2\pi}{3}\right) \\ \cos(\omega t) & \cos\left(\omega t - \frac{2\pi}{3}\right) & \cos\left(\omega t + \frac{2\pi}{3}\right) \end{bmatrix} \times \begin{bmatrix} v_{sa} \\ v_{sb} \\ v_{sc} \end{bmatrix} \quad (3.1)$$

$$\begin{bmatrix} i_d \\ i_q \end{bmatrix} = \sqrt{\frac{2}{3}} \begin{bmatrix} \sin(\omega t) & \sin\left(\omega t - \frac{2\pi}{3}\right) & \sin\left(\omega t + \frac{2\pi}{3}\right) \\ \cos(\omega t) & \cos\left(\omega t - \frac{2\pi}{3}\right) & \cos\left(\omega t + \frac{2\pi}{3}\right) \end{bmatrix} \times \begin{bmatrix} i_{sa} \\ i_{sb} \\ i_{sc} \end{bmatrix} \quad (3.2)$$

Equation 3.1 and 3.2 gives voltage and currents in d-q format. Using values obtained from above equations, three phase active and reactive power are calculated using following equations:

$$P = \frac{3}{2} (v_d \times i_d + v_q \times i_q) \quad (3.3)$$

$$Q = \frac{3}{2} (v_q \times i_d - v_d \times i_q) \quad (3.4)$$

The instantaneous active and reactive power obtained contains oscillations as well as average components. To compute average components, low pass filters are used to output both powers. Tracking active and reactive power reference commands is vital to the control [51]. For this

purpose, two PI control loops are implemented which generate active current reference i_d^* and reactive current reference i_q^* through following equations [51]:

$$i_d^* = k_{pp}(P_{ref} - P) + k_{ip} \int (P_{ref} - P) dt \quad (3.5)$$

$$i_q^* = k_{pq}(Q_{ref} - Q) + k_{iq} \int (Q_{ref} - Q) dt \quad (3.6)$$

Integral constants for PI controller are K_{ip} and K_{iq} , whereas, K_{pp} and k_{pq} are proportional constants. The reference value of reactive power acquired by power grid is given by Q_{ref} and active power for charging is P_{ref} .

Two loops are used in design of GSC controller. Outer voltage loop and inner current loop. The current reference is obtained by comparing voltage reference with actual voltage on outer loop which is then used to control inner current loop [51]. Comparing the current reference obtained in equation (3.5) and (3.6) with actual line currents obtained through park transformation, results in control of inner loop. The results (e_d and e_q) are first summed with decoupling terms and are then normalized by DC-link voltage to get duty ratios in d-q coordinate summarized in following equations [51]:

$$\begin{bmatrix} d_d \\ d_q \end{bmatrix} = \frac{1}{V_{dc}} \begin{bmatrix} e_d + v_d + 3\omega L \times i_q \\ e_q + v_q - 3\omega L \times i_d \end{bmatrix} \quad (3.7)$$

However, to obtain duty ratios in a-b-c frame of reference, inverse matrix transformation technique is utilized as shown below [51]:

$$\begin{bmatrix} D_a \\ D_b \\ D_c \end{bmatrix} = \sqrt{\frac{2}{3}} \begin{bmatrix} \sin(\omega t) & \cos(\omega t) \\ \sin\left(\omega t - \frac{2\pi}{3}\right) & \cos\left(\omega t - \frac{2\pi}{3}\right) \\ \sin\left(\omega t + \frac{2\pi}{3}\right) & \cos\left(\omega t + \frac{2\pi}{3}\right) \end{bmatrix} \times \begin{bmatrix} d_d \\ d_q \end{bmatrix} \quad (3.8)$$

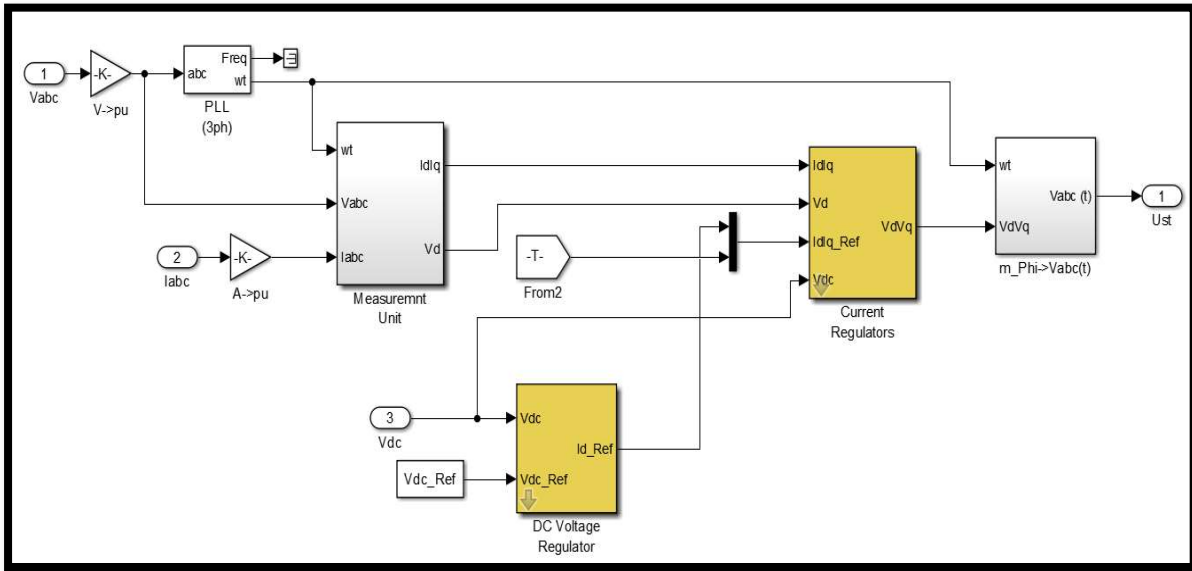

Figure 3.3: Grid side converter Simulink block diagram [51]

3.3.2 Local controller

GSC controller plays an important role in providing surplus active power for charging EV batteries, as well as, support utilities with reactive power for electric grid. However, it doesn't control charging and discharging currents of EV batteries or interact with utilities directly. Here, the local controller plays its part. Local controller in this study model of V2G infrastructure act as an aggregator. It is directly connected with controlled current source and interact with utilities to decide charging and discharging of EV batteries. In addition, since local controller interacts with utilities, reactive power request from utilities is received by local controller and in turn it generates a signal for GSC to provide reactive power to grid. It also plays an important function of controlling amount of charging current of battery, in grid-to-vehicle (G2V) mode, and discharging current, in V2G mode.

Local controller interacts with utilities to obtain forecasted power demand in order to determine (dis)charging schedule. Besides, local controller also has charging profiles of EVs available in a region/area to further facilitate scheduling process. By communication with both utilities and EV fleet, local controller determines a schedule based on how much power is required by EV batteries

for charging and how much power is available to support V2G operation using EV batteries for peak shaving and load leveling.

The local controller has three main input signals and it employs an algorithm, according to some set criteria based on available EV and utility power profile, to manipulate the three input signals to run G2V or V2G operation. The three input signals of local controller are: user signal, utility load profile signal and state of charge (SOC) of EV batteries available. The amount of charging and discharging current in G2V and V2G mode, respectively, is a function of SOC therefore using SOC as one of local controller's input is very vital to the operation. The information received by three input signals of local controller are elaborated below:

User signal: user input of local controller determines when EV is required to be charged, that is G2V mode, or when EV battery is available to supply active power to grid, V2G mode. User input has highest priority in local controller algorithm because owner decides if EV can be discharged to compensate for peak load of utilities or not. If the owner wants EV to be charged, regardless of utility load, EV charger is not allowed to provide active power to utilities. However, if EV is in an idle state, charger is allowed to supply active power to utilities from EV battery depending on its SOC, which is usually agreed between EV owner and utilities. In this study model, user input '0' indicates that charging must be initiated and until the user input is '0', charging should not be stopped, as long as battery is not fully charged.

Utility load profile signal: utility input of local controller receives information of daily load profile. The local controller analyses load profile and determines how much active power is available in EV batteries to support utilities. Local controller then determines time of day when EVs are in idle state and can provide active power. Simultaneously, it also determines time of day when utility load is minimum and provides a charging schedule for EV owners to charge in those hours to level overall utility load, saving money for utilities and EV owners. In addition to active power support, local controller receives signal from utilities for reactive power support. Based on utility request, local controller calculates and sends a reference signal to GSC, in order to provide reactive power to grid using AC-DC converter DC-link.

State of charge: state of charge (SOC) is the equivalent of a fuel gauge for battery pack in electric vehicles and is the third and most important input of local controller for G2V and V2G operation.

The amount of charging current required for charging EV battery is a function of its SOC. SOC determines how much charging current is required within a range of battery SOC. For example, if battery has 20% SOC, that means EV battery needs to be charged quickly and hence a higher charging current is required to charge battery in minimum time. Similarly, if the battery SOC is 80% then amount of charging current needs to be reduced to a very low value, relatively, to top battery to 100% and then reduced to zero when SOC reaches 100%. However, SOC is not only important for G2V operation, it plays a vital role in V2G mode as well. An agreement is charted between EV owner and local controller which entails that EV battery can be used for V2G operation if battery SOC is above a particular percentage. For example, if the agreement says above 40%, then EV battery can be used for V2G operation if and only if the battery SOC is above 40%. If SOC is less than 40% in this scenario, local controller is not allowed to operate EV batteries in V2G mode. Therefore, SOC is an important input signal to local controller for G2V and V2G operation.

The above three input signals determine the mode of operation for local controller, as established. However, data received using three input signals need to be manipulated in a way to perform G2V and V2G operation. For this purpose, local controller employs an algorithm to support this operation. The algorithm takes values from three input signals of local controller and determine an appropriate mode of operation which satisfies both electric utilities and EV owners.

3.3.2.1 Local controller algorithm

The algorithm of local controller is based on flow chart shown in Figure 3.4. The user input in this study has maximum value of '1' and minimum value '0', represented by U in Figure 3.4. '0' indicates that owner of EV has demanded charging of EV battery and it is given highest priority in this study. '1' indicates that EV battery is available for supplying active power to grid when demanded by utility. However, for supplying power to utility a threshold of 40% SOC is used. Meaning, if SOC of battery is greater than 40%, EV battery can supply active power to power grid and if SOC is less than or equal to 40%, EV battery cannot be used to supply power to utilities. In Figure 3.4, S represents SOC of battery.

When EV is in idle state, user input is '1', and battery SOC is above 40% EV battery is ready to supply active power to utility on request. According to load profile signals exchanged between

utility and local controller, during idle hours of EV, local controller takes available active power from EV battery and gives it to utility to reduce peak load during peak power demand hours. In addition, for reactive power support, local controller corresponds to utility request immediately. Reactive power is supplied using AC-DC inverter DC-link which is triggered by local controller by sending a signal of reference q-axis current to GSC. Again, in this scenario, if cars are being charged and there is not enough power from grid side to support reactive power demand, this demand is put on hold until there is enough power to supply reactive power.

The main task of local controller is to supply power required for charging and support of electric grid, based on above mentioned criteria. The required power is calculated inside the local controller and coordinated with conditional statements to satisfy algorithm criteria. The calculations along with conditional statements of algorithm applied in this study are elaborated below:

$$P_{demand} = P_{load} - P_{threshold} \quad (3.9)$$

Where, P_{demand} = active power demanded by utilities;

P_{load} = load profile of utilities;

$P_{threshold}$ = threshold power set by local controller to meet demand

$$Q_{required} = Q_{reference} - Q_{demand} \quad (3.10)$$

Where, $Q_{required}$ = reactive power to be supplied to utilities;

$Q_{reference}$ = reference reactive power to determine $Q_{required}$;

Q_{demand} = reactive power demanded by utilities

- If user input is '1', P_{demand} is greater than zero and SOC of battery is greater than 40%; utilities can be provided with active power from EV battery. To provide this active power, discharge current signal is sent to controlled current source. The amount of discharge current for controlled current source is measure using equation (3.11)

$$\frac{P_{required}}{V_{dc}} \quad (3.11)$$

- If user input is '0' then EV battery must be charged regardless of power demand from utilities. The charging of EV battery is a function of SOC and four are three conditions to determine charging currents:

1. If SOC is greater than or equal to 20% and less than 60%, EV battery must be charged at a higher rate with minimum charging time. Therefore, a maximum charging current signal is fed to controlled current source
 2. If SOC is greater than or equal to 60% and less than 80%, EV battery must be charged at a bit lower rate relative to first condition with minimum charging time. Therefore, a bit lower charging current signal is sent to controlled current source
 3. If SOC is greater than or equal to 80% and less than 100%, EV battery must be charged at a much lower rate to top up battery to 100%. Minimum charging current signal is sent to controlled current source.
 4. If SOC reaches 100%, the charging current is reduced to zero
- Reactive power demand is continuously monitored at all times and whenever reactive power required is greater than zero a reference q-axis current is generated and sent to GSC to provide utilities with required reactive power using equation (3.10).

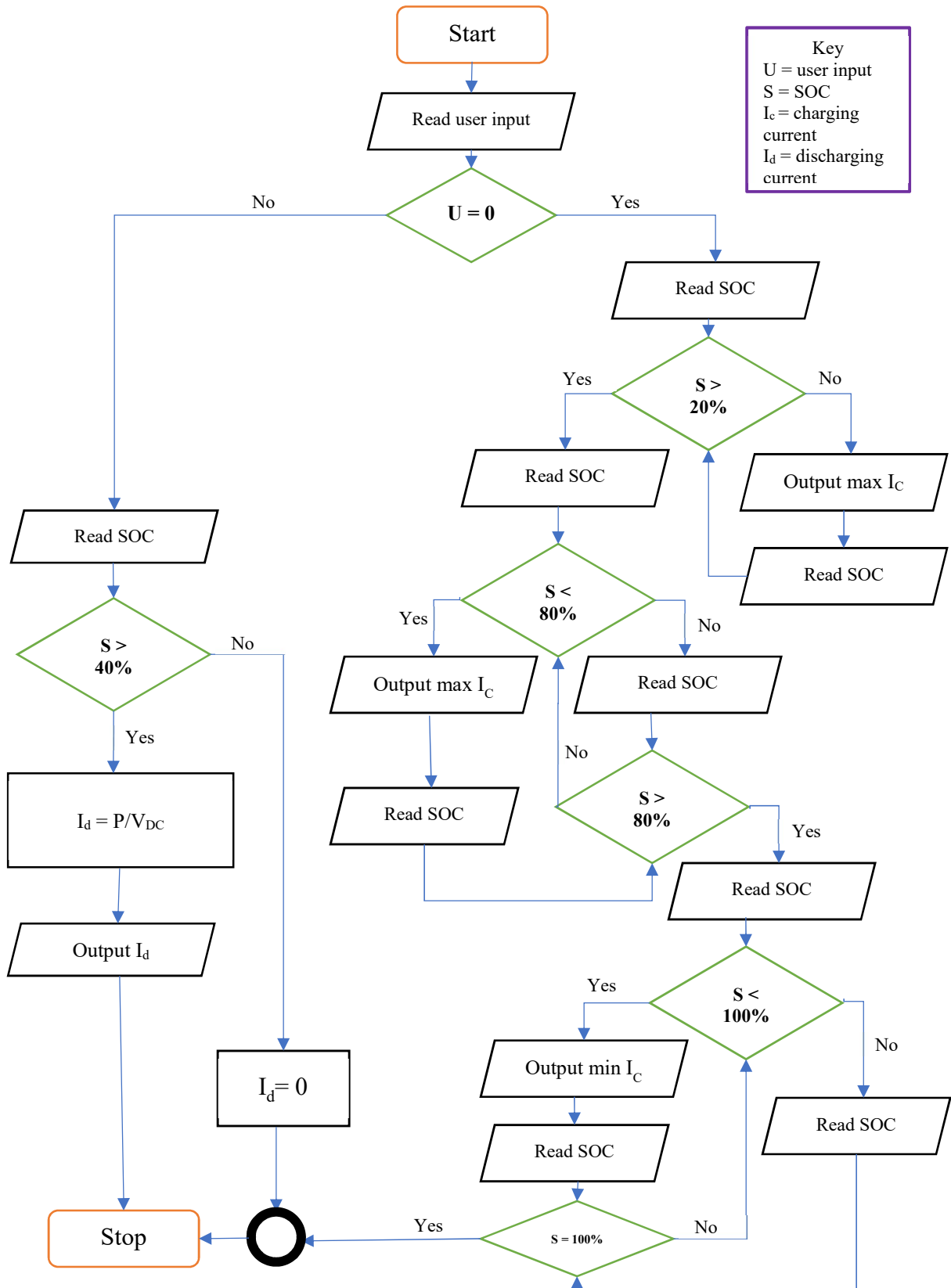

Figure 3.4: Algorithm for local controller

3.4 Method

3.4.1 Case study

The charging station setup and local controller designed in this chapter address charging and discharging of EVs connected with electric grid, to support V2G operation. For verification of results, two case studies are formulated in this study. The case studies are presented in chapter 5 along with parameters used to verify the designed model.

First case study verifies working of V2G model designed in this chapter, that is, EVs are charging using grid power and discharged to support active power demand of electric utilities. Concurrently, the first case study also verifies reactive power support for utilities. It is referred as case study A in chapter 5.

Second case study verifies a test model of V2G scenario and forms an understanding of how EV batteries provide active power support to utilities over a period of 24 hours. This case study forms foundation of peak shaving and load leveling, which is used to form optimization technique used in next chapter of this study, to address smart charging strategy. This case study is referred as case study B in chapter 5.

3.4.2 Implementation

The V2G infrastructure developed in this chapter of study is implemented in MATLAB Simulink®. The libraries used for implementing the said model in MATLAB Simulink are Simulink and Simscape.

In addition, to implement model designed in this chapter, instead of DC-DC bidirectional power converter, controlled current source is used to perform same function as DC-DC converter. Controlled current source is an electronic circuit which delivers or absorbs currents independent of voltage across it. It requires a control signal which is the amount of current it will retain across it regardless of voltage change across it [52].

4 Utility's Role in V2G

Vehicle-to-grid (V2G) has many potential advantages that can benefit both, electric utilities and EV owners. However, the advantages highly depend on charging schedules regulated by utilities. Without smart charging schedules, integrating large fleet into electric grid can cause negative impacts on electric grid, as established in chapter 2. Finding appropriate and efficient smart charging schedule is where utilities play their role in V2G technology. Electric utilities can manage load in order to reduce peak load demand and level load. Meaning, EVs charge their batteries in an off-peak time and support utilities with active power support during peak load hours. The most efficient way to manage load in V2G scenario is by deploying an optimization technique, which delivers effective results and reduces cost of charging for utilities, as well as, EV owners. This chapter of study develops an optimization technique which can be regulated by electric utilities, with help of aggregators, to minimize overall peak power demand and spread EV charging schedule during off-peak hours.

4.1 System model and description

The purpose of this chapter in study is to explore and formulate an optimization method that minimizes cost of charging EVs. The cost of minimizing EVs can further be explained as, if EVs participate in V2G operation to provide ancillary services to electric utilities, such as, peak load shaving and load leveling, EV owners will be given monetary incentives according to amount of power they provide to utilities. Furthermore, if EVs charge during off-peak hours, utilities don't have to pay for extra generation of electric power, to compensate for added load of EVs charging during peak load hours, which will benefit both, utilities and EV owners. Meaning, power provided to utilities will be awarded with money which can be directed towards charging EVs, as compared

to where EVs only take power from utilities and pay power consumption. Hence, minimized cost of charging.

The first and foremost element to implement optimization is to develop a mathematical model for electric vehicle that can be used in charging and discharging process. The key element involved in V2G operation is battery of EVs. A simple battery model can be composed of its state of charge (SOC), charging current and capacity of battery. The only state variable in this model is SOC. It is much simpler to represent EV battery model in state space form which fits into optimization technique as shown in equation (4.1).

$$\dot{SOC} = \mathbf{A} \cdot SOC + \mathbf{B} \cdot I \quad (4.1)$$

Where, SOC is the state variable, I is control variable representing charging and discharging current of EV battery, \mathbf{A} is identity matrix and \mathbf{B} is a vector containing battery capacity. In this study, continuous state space model is converted into a discrete state space representation of battery model which fits into optimization constraints. Discrete time state space representation of battery model used in this study is given by equation (4.2).

$$SOC_{k+1} = \mathbf{A} \cdot SOC_k + \mathbf{B} \cdot I_k \quad (4.2)$$

Where k denotes current time step. The model presented in (4.2) is a general model of EV participating in V2G scenario. For number of EVs participating in V2G scenario, equation (4.2) can be transformed into following format:

$$\begin{bmatrix} SOC_{k+1}^1 \\ \vdots \\ SOC_{k+1}^U \\ \vdots \\ SOC_N^1 \\ \vdots \\ SOC_N^U \end{bmatrix} = \mathbf{A} \begin{bmatrix} SOC_k^1 \\ \vdots \\ SOC_k^U \\ \vdots \\ SOC_{N-1}^1 \\ \vdots \\ SOC_{N-1}^U \end{bmatrix} + \mathbf{B} \begin{bmatrix} I_k^1 \\ \vdots \\ I_k^U \\ \vdots \\ I_{N-1}^1 \\ \vdots \\ I_{N-1}^U \end{bmatrix} \quad (4.3)$$

Where, $k = 0, 1, 2, 3, \dots N$;

N = total number of time steps;

U = total number of EVs

As mentioned above, purpose of developing a discrete time state space model for EV battery is to use it in constraints of optimization technique implemented in this study. Since, (4.3) is an equality relation, battery model is used in equality constraints of optimization model. However, to use it as equality constraint, it must be converted into a standard form given by equation (4.4).

$$\mathbf{A}_{eq} \cdot \mathbf{z} = \mathbf{b}_{eq} \quad (4.4)$$

Where \mathbf{z} is a vector containing all state variables and control variable for each EV and each time step, that is, SOC and (dis)charging current at each interval. In standard form, equation (4.2) becomes:

$$-\mathbf{A}SOC_k + SOC_{k+1} - \mathbf{B}I_k = 0 \quad (4.5)$$

And (4.5) can be written in standard form of (4.4) as following:

$$\underbrace{\left[\begin{array}{cccc|cccc} I & 0 & \dots & \dots & 0 & -\mathbf{B} & 0 & \dots & \dots & 0 \\ -\mathbf{A} & I & \ddots & \ddots & \vdots & 0 & \ddots & \ddots & \ddots & \vdots \\ 0 & \ddots & \ddots & \ddots & \vdots & \vdots & \ddots & \ddots & \ddots & \vdots \\ \vdots & & & & 0 & \vdots & & & & 0 \\ 0 & \dots & 0 & -\mathbf{A} & I & 0 & \dots & \dots & 0 & -\mathbf{B} \end{array} \right]}_{\mathbf{A}_{eq}} \cdot \underbrace{\begin{bmatrix} SOC_{k+1}^1 \\ \vdots \\ SOC_{k+1}^U \\ \vdots \\ SOC_N^1 \\ \vdots \\ SOC_N^U \\ I_k^1 \\ \vdots \\ I_k^U \\ \vdots \\ I_{N-1}^1 \\ \vdots \\ I_{N-1}^U \end{bmatrix}}_{\mathbf{z}} = \underbrace{\begin{bmatrix} \mathbf{A}_0 SOC_k^1 \\ \vdots \\ \mathbf{A}_0 SOC_k^U \\ 0 \\ \vdots \\ 0 \end{bmatrix}}_{\mathbf{b}_{eq}} \quad (4.6)$$

Where, $\mathbf{A} = U \times U$ identity matrix;

\mathbf{B} = EV capacity vector;

$k = 0, 1, 2, 3, \dots N$

The first matrix on left-hand side of (4.6) is equivalent to \mathbf{A}_{eq} of equation (4.4), second vector represents \mathbf{z} of equation (4.4) and finally, right-hand side vector in (4.6) is equivalent of \mathbf{b}_{eq} of equation (4.4) and holds initial value of SOC for each car. It is to be noted here that number of rows in \mathbf{A}_{eq} are equal to number of rows in \mathbf{b}_{eq} . From above equations, system model for optimization is developed which will be used in next sections of this chapter.

4.2 Problem statement

As established, purpose of this chapter in study is to develop an optimization model that minimizes cost of charging for electric utilities and EV owners. Optimization techniques use mathematical model of problem at hand. In this section, problem statement is elaborated and mathematical form is obtained for optimization.

Optimization method deployed in this study to develop smart charging strategy is based on minimizing total cost of charging EVs for utilities and EV owners. This is possible when EVs participate in aggregated V2G scenario. Meaning, EVs provide power to utilities during peak load hours and charge batteries during off-peak hours. In general, it can be stated as minimizing grid power over a period of 24 hours for peak shaving and load leveling. When grid power is minimized, load profile of individual area or region is minimized at peak points by taking power from EV batteries. Simultaneously, giving power to EV batteries during time of the day when power consumption is minimum. This can be expressed in general mathematical notation as:

$$\min(P_{grid}^2) \quad (4.7)$$

Where,

$$P_{grid} = P_{load\ profile} + P_{charging} \quad (4.8)$$

P_{grid} is grid power, $P_{load\ profile}$ is everyday power demand profile of an area/region without charging power for EVs, and $P_{charging}$ is charging power of EVs. In equation (4.8), $P_{load\ profile}$ is the known parameter in optimization and $P_{charging}$ is optimized in such a way that overall grid power is minimized. The problem is then simplified to find following tasks:

- I. When to charge EV batteries;
- II. When (and if) to discharge EV batteries for V2G scenario;

Such that, peak net power consumption and its variability over a period of 24 hours is minimized.

In this study, two models are created in which grid power is minimized to reduce cost of charging. One model optimizes charging schedule of overall grid load in a region, where residential, industrial and commercial loads are treated as one grid load in collective. Whereas, second model optimizes charging schedule of each individual area using load profile of that specific area. For instance, smart charging schedule for EVs in residential area to minimize residential power demand from utilities.

4.2.1 Optimization technique

The optimization technique adopted for this study is quadratic programming. It minimizes overall grid load while maintaining desired SOC for EV owners. Equation (4.9) gives general form of quadratic programming.

$$\text{minimize } \left(\frac{1}{2} x^T H x + f^T x \right) \quad (4.9)$$

Subject to;

$$Ax \leq b \quad (4.10)$$

$$A_{eq}x = b_{eq} \quad (4.11)$$

$$l_b \leq x \leq u_b \quad (4.12)$$

Where, \mathbf{x} = state vector equivalent to vector \mathbf{z} developed in section 4.1;

\mathbf{x}^T = transpose of vector \mathbf{x} ;

\mathbf{H} = weight matrix used to design quadratic term of objective function;

\mathbf{f}^T = weight vector to design linear term of objective function;

Equations 4.10 to 4.12 give constraints which represent process of quadratic optimization to minimize objective function. Here, equation (4.10) is inequality constraint, (4.11) is equality constraint, and (4.12) represent boundary conditions for design criteria, with l_b as lower bound and u_b as upper bound.

The next sections of this chapter develop objective function and respective constraints for regional load control optimization and area load control optimization for quadratic programming implementation to minimizing utility power.

4.3 Regional load control

Regional load control in this study refers to smart charging schedule for a region consisting of collective power demand of residential, commercial and industrial area. Utility in this control strategy devises a smart schedule for the whole region based on a single load profile curve. This single load profile curve is a sum of total power demand of industrial, residential and commercial areas over a period of 24 hours. Figure 4.1 shows load profile curve of a region used in this study for utility/aggregator regional load control strategy.

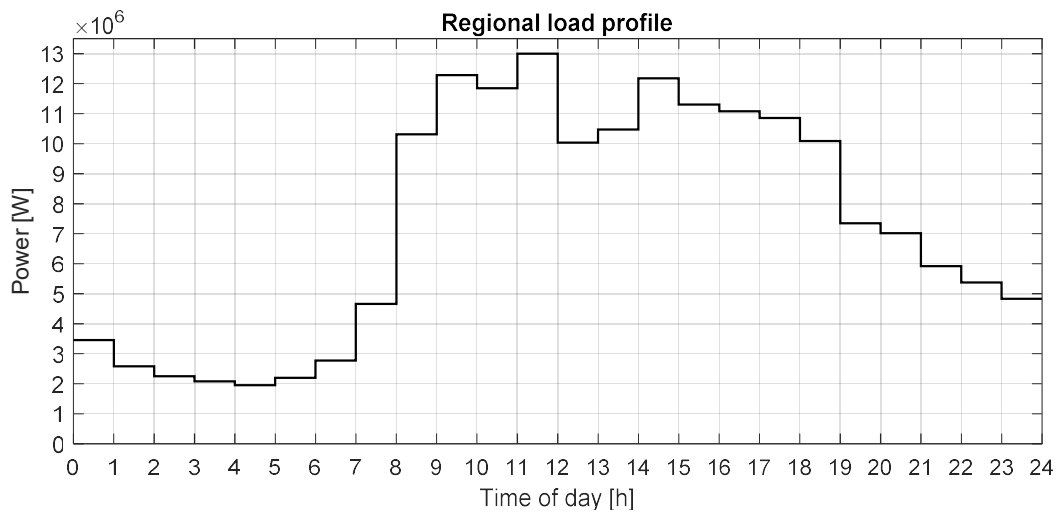

Figure 4.1: Regional load profile

Figure 4.1 shows that power demand between 09:00 and 18:00 is at its peak during the day. Optimization technique developed in this study will minimize this peak load by providing power from EV batteries to utility in order to flatten load curve, as much as possible, during peak load hours. In addition, charging of EVs will be scheduled such that, EV batteries take power from utilities between 19:00 and 08:00 hours.

4.3.1 Objective function

The problem for smart scheduling strategy is defined in previous sections of this chapter. Using problem description, objective function for optimization can be formulated. Let decision variable P_t denote utility power demand at interval t and $C_{i,t}$ denote charging power for each EV i at interval t . It is to be noted here that, charging and discharging power over an interval t is constant.

The duration of each time interval t is set to one hour, since utility load profile data is available on hourly basis with consideration that smaller time steps make problem computationally heavy. Further P_t is a sum of power demand in residential, commercial and industrial areas at time interval t . It can be represented by equation (4.13).

$$P_t = P_t^{residential} + P_t^{industrial} + P_t^{commercial} \quad (4.13)$$

Where, $P_t^{residential}$ = power demand in residential area at interval t

$P_t^{industrial}$ = power demand in industrial area at interval t

$P_t^{commercial}$ = power demand in commercial area at interval t

The objective function can be written in the form presented in equation (4.14).

$$\min \sum_{t=1}^T \sum_{i=1}^U (P_t + C_{i,t})^2 \quad (4.14)$$

Further, substituting equation (4.13) in (4.14) yields complete objective function for optimization model used in this study.

$$\min \sum_{t=1}^T \sum_{i=1}^U \left((P_t^{residential} + P_t^{industrial} + P_t^{commercial}) + C_{i,t} \right)^2 \quad (4.15)$$

4.3.2 Constraints

Minimizing utility power is subjected to some predefined charging and discharging constraints stated and elaborated in this section.

- Charging current $I_{i,t}^c$ for each EV i , at each interval t , is defined within minimum and maximum charging current limits. Minimum charging current is defined as negative and denoted by $I^{c,min}$. Minimum charging current in this study refers to maximum discharging current to discharge EV batteries. On the contrary, maximum charging current is defined as positive and denoted by $I^{c,max}$. Maximum charging current refers to charging current for charging EV batteries. Hence, charging current is constrained to within limits.

$$I_i^{c,min} \leq I_{i,t}^c \leq I_i^{c,max} \quad \forall t, i \quad (4.16)$$

- After each time step t , state of charge of each EV i needs to be updated. $S_{i,t}$ denotes SOC of each EV for present time interval and $S_{i,t-1}$ denotes SOC of each EV battery at previous time interval. Moreover, b_i represents capacity of each EV battery i , $I_{i,t-1}^c$ denotes charging and/or discharging current of each EV battery at previous interval ($t-1$).

$$\{S_{i,t} = S_{i,t-1} + b_i I_{i,t-1}^c \quad \forall t, i \quad (4.17)$$

- SOC ($S_{i,t}$) of each EV battery i at each interval t is constrained within limits to keep battery life from deterioration. SOC of each EV battery i is defined as positive and is limited between minimum SOC (S^{min}) and maximum SOC (S^{max}). Battery of each EV is not allowed to drain below S^{min} . Concurrently, SOC cannot increase beyond S^{max} .

$$S_i^{min} \leq S_{i,t} \leq S_i^{max} \quad \forall t, i \quad (4.18)$$

- In addition, during discharging process of EV battery to support utility with active power, minimum state of charge (SOC) is bound for each EV battery i according to EV owner's desire at specific time interval in this study. For example, if a user desire that SOC of car is kept at minimum level of 45% by 16:00, then it is prioritized in this optimization model. $S^{desired}$ denotes desired SOC at desired time interval $t^{desired}$.

$$S_i^{min} \leq S_{i,t}^{desired} \quad \forall i, t = t^{desired} \quad (4.19)$$

- Charging and discharging power of each EV battery i at each interval t is obtained as a result of equality constraint. Positive $C_{i,t}$ represents charging power and, alternately, negative $C_{i,t}$ gives discharging power of each EV battery i . V_{DC} is voltage across DC-DC converter.

$$\{C_{i,t} = I_{i,t}^c V_{DC} \quad \forall t, i \quad (4.20)$$

- Further, charging and discharging power of EV batteries, $C_{i,t}$, is constrained to within limits. The charging power is defined as positive and discharging power is defined as

negative. C^{min} denotes maximum discharging power and C^{max} denotes maximum charging power for EV battery.

$$C_i^{min} \leq C_{i,t} \leq C_i^{max} \quad \forall t, i \quad (4.21)$$

- Finally, utility power (P) is kept within limits as well. Minimum utility power is defined as zero and maximum utility power is defined as a positive sum of power demand and max (dis)charging power of EV batteries connected in a region.

$$0 \leq P_t \leq P_t + \sum_i C_i^{max} \quad \forall t, i \quad (4.22)$$

4.3.3 Complete optimization problem

After defining objective function and constraints, now complete optimization problem can be written as it is implemented to achieve results in this study.

The objective function is:

$$\min \sum_{t=1}^T \sum_{i=1}^U \left((P_t^{residential} + P_t^{industrial} + P_t^{commercial}) + C_{i,t} \right)^2 \quad (4.23)$$

Objective function is subjected to set of constraints given by (4.24).

$$\left\{ \begin{array}{l} I_{i,t}^c \geq I_i^{c,mi} \\ I_{i,t}^c \leq I_i^{c,max} \\ S_{i,t} = S_{i,t-1} + b_i I_{i,t-1}^c \\ S_{i,t} \geq S_i^{min} \\ S_{i,t} \leq S_i^{max} \\ S_i^{min} \leq S_{i,t}^{desired} \quad \forall i, t = t^{desired} \\ C_{i,t} = I_{i,t}^c V_{DC} \\ C_{i,t} \geq C_i^{min} \\ C_{i,t} \leq C_i^{max} \\ P_t = P_t^{residential} + P_t^{industrial} + P_t^{commercial} \\ P_t \geq 0 \\ P_t \leq P_t + P_t + \sum_i C_i^{max} \end{array} \right. \quad \forall t, i \quad (4.24)$$

4.4 Area load control

The second scheduling strategy adopted in this study is based on load control of an individual area, referred as area load control. Area load control optimization schedules charging and discharging of EV batteries to support utilities in peak shaving and load leveling of a specific area as opposed to a collective load of all areas in regional load control strategy. For example, EVs available in residential area will help in peak shaving and load leveling of power demand in residential area over a period of 24 hours. Similarly, same strategy is used to schedule charging and discharging of EVs in commercial and industrial area. Method of optimization is similar to the one used for regional load control strategy, that is, quadratic programming is used in this method as well to find optimal charging schedule. The following sections of this chapter further elaborate the concept.

4.4.1 Residential load scheduling

Residential load scheduling refers to scheduling (dis)charging of EV batteries to flatten power demand curve during peak load hours. Figure 4.2 shows a typical residential load curve. According to curve, peak load hours fall between 19:00 and 23:00 hours. The optimal schedule devised in this scheduling strategy flattens this peak load by using maximum power available in EV batteries in residential area and charge EV batteries during off-peak hours.

4.4.1.1 Objective function and constraints

The objective function for residential load scheduling is similar to objective function of regional load control, except, utility power in this optimization is reduced to only residential power demand. The objective function for residential load scheduling is given by equation (4.25). The variables used here are same, as used in regional load control, to understand problem at hand clearly.

$$\min \sum_{t=1}^T \sum_{i=1}^U (P_t^{residential} + C_{i,t})^2 \quad (4.25)$$

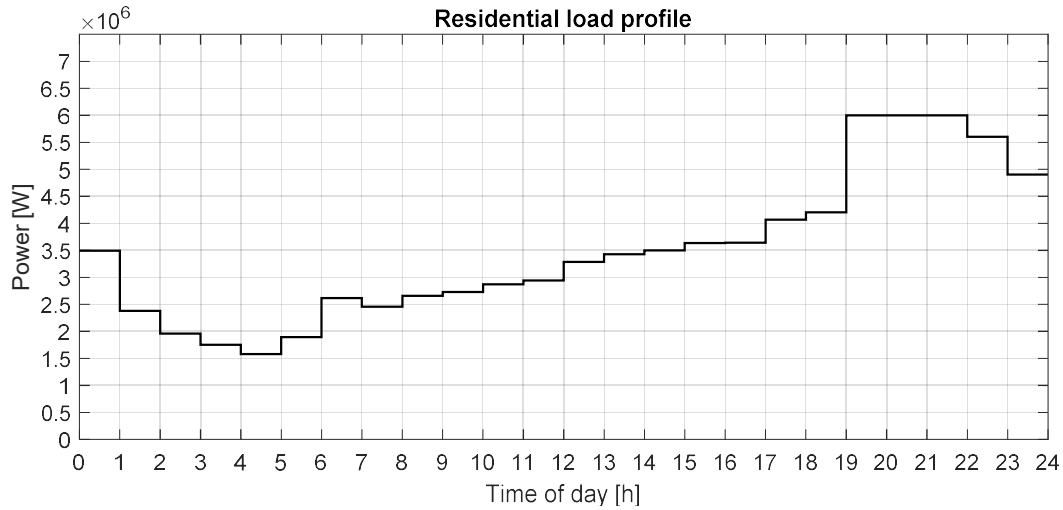

Figure 4.2: Residential load profile

Objective function in (4.26) is subjected to set of constraints in (4.26) to find an optimal scheduling solution.

$$\left\{ \begin{array}{l}
 I_{i,t}^c \geq I_i^{c,min} \\
 I_{i,t}^c \leq I_i^{c,max} \\
 S_{i,t} = S_{i,t-1} + b_i I_{i,t-1}^c \\
 S_{i,t} \geq S_i^{min} \\
 S_{i,t} \leq S_i^{max} \\
 S_i^{min} \leq S_{i,t}^{desired} \quad \forall i, t = t^{desired} \\
 C_{i,t} = I_{i,t}^c V_{DC} \\
 C_{i,t} \geq C_i^{min} \\
 C_{i,t} \leq C_i^{max} \\
 P_t = P_t^{residential} \\
 P_t \geq 0 \\
 P_t \leq P_t + \sum_i C_i^{max}
 \end{array} \right. \quad \forall t, i \quad (4.26)$$

The constraints used for residential load scheduling are the same as constraints used for regional load control, except, the last three constraints where utility power is limited by residential power demand and sum of maximum charging power of each EV.

4.4.2 Industrial load scheduling

Similar to residential load scheduling, industrial load scheduling works in the same manner, except, peak load hours in industrial load profile fall between 08:00 and 16:00 hours. Load profile curve of industrial area is given in Figure 4.3.

4.4.2.1 Objective function and constraints

Objective function in this optimal scheduling problem is now reduced to equation (4.27). The variables used are same as used in regional load control to understand the problem at hand clearly.

$$\min \sum_{t=1}^T \sum_{i=1}^U (P_t^{industrial} + C_{i,t})^2 \quad (4.27)$$

The set of constraints for objective function in (4.27) are same as (4.26) except last three constraints used according to industrial power demand. The complete set of constraints is given by (4.28).

$$\left\{ \begin{array}{l} I_{i,t}^c \geq I_i^{c,min} \\ I_{i,t}^c \leq I_i^{c,max} \\ S_{i,t} = S_{i,t-1} + b_i I_{i,t-1}^c \\ S_{i,t} \geq S_i^{min} \\ S_{i,t} \leq S_i^{max} \\ S_i^{min} \leq S_{i,t}^{desired} \quad \forall i, t = t^{desired} \\ C_{i,t} = I_{i,t}^c V_{DC} \\ C_{i,t} \geq C_i^{min} \\ C_{i,t} \leq C_i^{max} \\ P_t = P_t^{industrial} \\ P_t \geq 0 \\ P_t \leq P_t + \sum_i C_i^{max} \end{array} \right. \quad \forall t, i \quad (4.28)$$

Here, in equation (4.28), the set of constraints is similar to set of constraints used for residential load control, except last three constraints where constraint is reduced to industrial power demand.

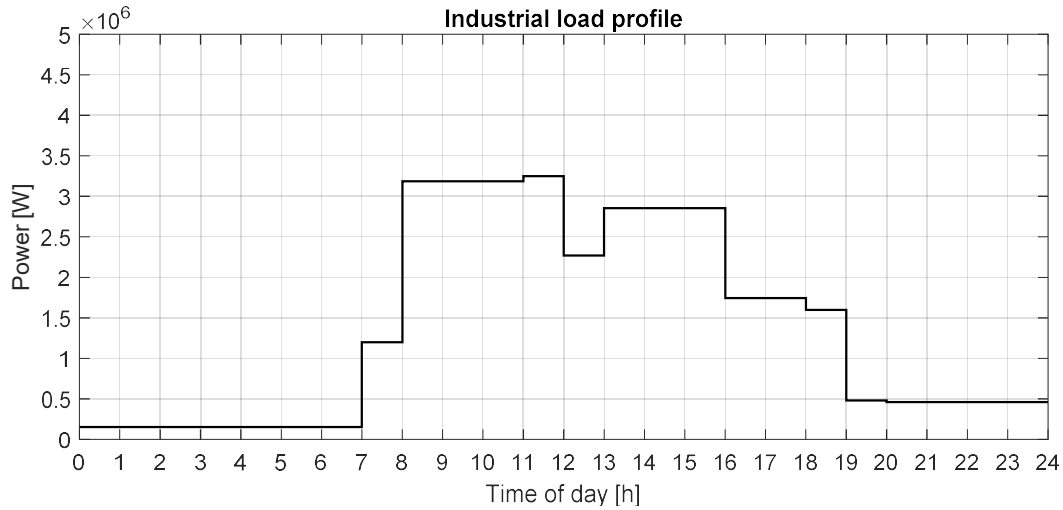

Figure 4.3: Industrial load profile

4.4.3 Commercial load schedule

Finally, commercial load scheduling is performed on a load profile shown in Figure 4.4. Again, the objective function of optimization is similar to regional load control's objective function. Here the utility power is reduced to only power demand in commercial area and peak power demand lies between 09:00 and 18:00 hours.

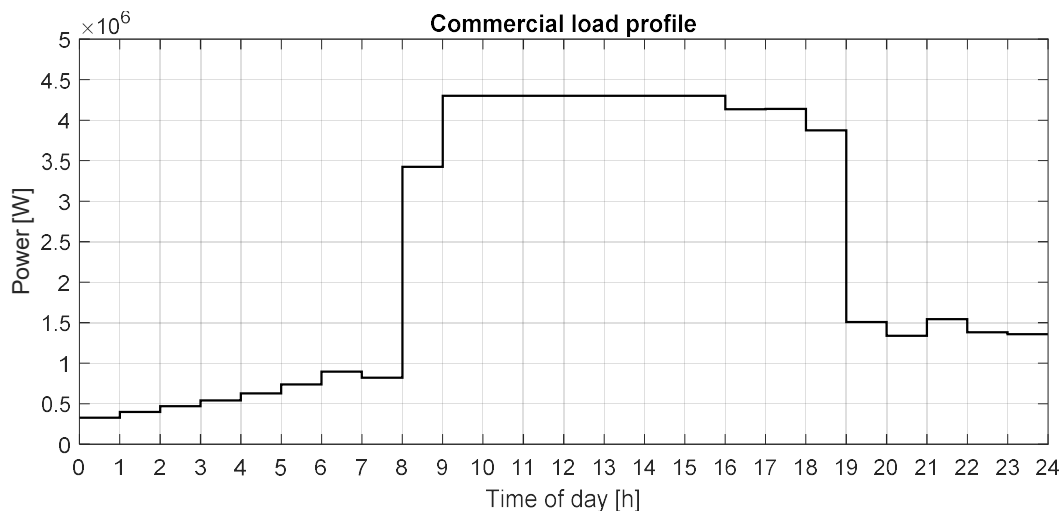

Figure 4.4: Commercial load profile

4.4.3.1 Objective function and constraints

The objective function of commercial load scheduling is presented in equation (4.30). Again, variables used here are kept the same as regional load control in order to have better understanding for comparison. The set of constraints for objective function in (4.30) is given in (4.31).

$$\min \sum_{t=1}^T \sum_{i=1}^U (P_t^{commercial} + C_{i,t})^2 \quad (4.29)$$

$$\left\{ \begin{array}{l} I_{i,t}^c \geq I_i^{c,min} \\ I_{i,t}^c \leq I_i^{c,max} \\ S_{i,t} = S_{i,t-1} + b_i I_{i,t-1}^c \\ S_{i,t} \geq S_i^{min} \\ S_{i,t} \leq S_i^{max} \\ S_i^{min} \leq S_{i,t}^{desired} \quad \forall i, t = t^{desired} \\ C_{i,t} = I_{i,t}^c V_{DC} \\ C_{i,t} \geq C_i^{min} \\ C_{i,t} \leq C_i^{max} \\ P_t = P_t^{commercial} \\ P_t \geq 0 \\ P_t \leq P_t + \sum_i C_i^{max} \end{array} \right. \quad \forall t, i \quad (4.30)$$

Again, set of constraints is the same as previous constraints, except last three constraints, where only industrial power demand is considered.

4.5 Method

4.5.1 Case study

The purpose of this chapter in this study is to address smart scheduling solution for EVs to participate in V2G technology with minimum charging cost for both, utilities and EV owners.

To verify successful results achieved from quadratic programming optimization models created in this chapter, 4 case studies are presented in chapter 5.

Case study C: regional load control.

Case study D: residential load scheduling.

Case study E: industrial load scheduling.

Case study F: commercial load control.

4.5.2 Implementation

The scheduling models designed in this chapter are implemented in MATLAB using built in MATLAB function ‘quadprog’ from optimization toolbox to solve smart charging problems.

5 Results and Discussion

5.1 V2G infrastructure results

The first objective of this study is to verify a working model of state-of-the-art V2G charging infrastructure. In this chapter, two case studies are developed to verify results of V2G model designed in chapter 3. The case studies formulated in this section address first objective of this study, that is, working model of V2G fast charging infrastructure connected with utilities and local controller (aggregator).

5.1.1 Case A – V2G infrastructure

In this case study, working model of charging infrastructure designed in chapter 3 is implemented in MATLAB Simulink, using Simulink and Simscape libraries.

Grid connected three-phase three-level bidirectional (TPTL) AC-DC converter used in this model for two-way flow of power between EV batteries and grid is taken from built-in MATLAB example, “AC/DC Three-Level PWM Converter”. Description of TPTL and simulation parameters for TPTL used in this study to develop charging station are given in Table 5.1 [53]. Furthermore, controlled current source is used as an alternative of bidirectional DC-DC converter to connect EV batteries with grid connected AC-DC converter and utility. The parameters used to model EV battery are given in Table 5.2. Table 5.3 gives parameters used for simulation of V2G charging infrastructure in MATLAB Simulink.

Table 5.1 TPTL description and simulation parameters [53]

Component	Parameter	Value
Converter ratings	Voltage	500 volts DC
	Power	500 kW
AC supply	Phase	Three-phase
	Voltage	600 V
	Apparent power	30 MVA
	Frequency	60 Hz
Voltage source converter (VSC)	Carrier frequency	1620 Hz
	DC-link	2 capacitors of 75000 μ F
Controller	PI regulators to control DC voltage	To maintain unity power factor for AC supply

This case study verifies working of V2G system based on some predefined signals designed and explained below:

User signal: user signal in case study A is a time-based signal with two values. ‘0’ represents charging is required regardless of utility demand. ‘1’ represents an idle state of EV in which discharging process can be carried out based on SOC threshold set by user. User signal is shown in Figure 5.1. According to Figure 5.1, EV is in idle state between 10 – 20 seconds and again between 40 – 50 seconds. Therefore, if SOC of EV battery is above user defined threshold, EV battery can provide active power support to utility during these time intervals.

Utility demand signal: in this case study, utility signal is designed as continuous signal with power deficits in both active and reactive power. Reference signals show a threshold utility must maintain to meet demand of a certain region at all times. In comparison, utility demand signal shows deficit in active and reactive power, which are compared with reference signals to determine how much

active and reactive power is required from EV batteries and AC-DC converter's DC-link, respectively.

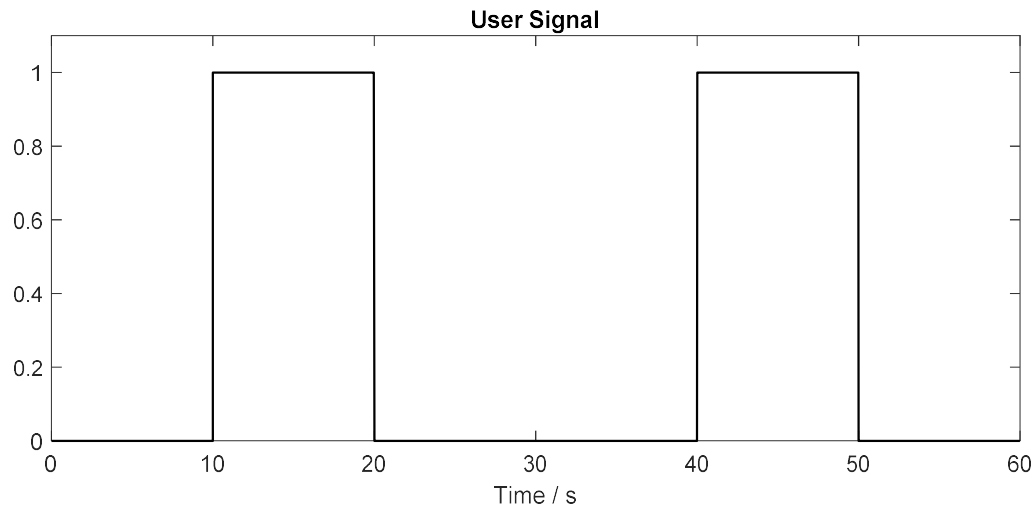

Figure 5.1: User signal

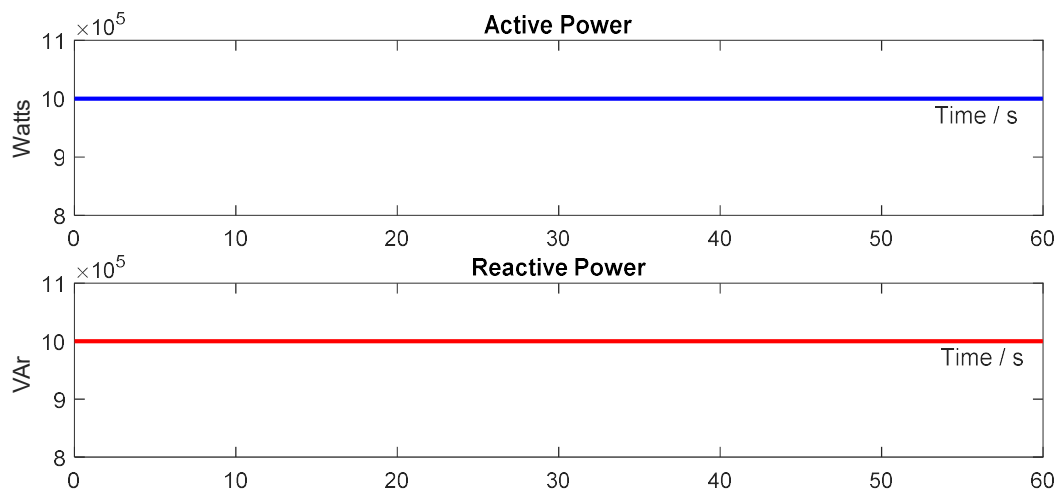

Figure 5.2: Utility reference signal

Figure 5.2 shows reference signals used by local controller and Figure 5.3 shows utility demand signal. Comparing Figure 5.2 and Figure 5.3 shows, there is active power deficit of 100 kW between 10 – 20 seconds and again active power deficit of 50 kW between 40 – 50 seconds. Furthermore, second demand signal, shown in red, in Figure 5.3 shows that there is reactive power deficit of 30 kVAR between 10 – 20 seconds and again reactive power deficit of 50 kVAR between 35 – 50 seconds.

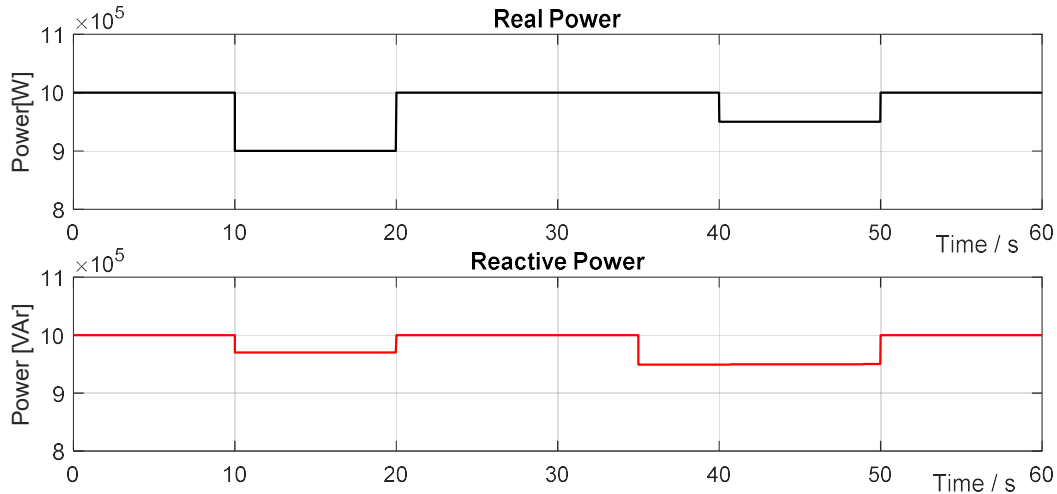

Figure 5.3: Utility demand signal

Table 5.2 Battery parameters and specifications

Parameter	Specification
Nominal voltage	360V
Capacity	210Ah
Initial SOC	57%
Battery response time	0.2s
Cut-off voltage	270V
Fully charged voltage	419.0354
Internal resistance	0.017143 ohms

According to signals shown in Figure 5.1, Figure 5.2 and Figure 5.3, and charging infrastructure developed in this study for V2G operation, accurate results are achieved. Figure 5.4 shows EV battery status after simulation of V2G system developed. The battery is taking power from grid to charge during user specified time intervals; between 0 - 10 seconds, 20 - 40 seconds and 50 - 60 seconds. It also provides active power support to utilities during idle state of EVs, when user signal is '1', between 10 - 20 seconds and again between 40 - 50 seconds, meanwhile, maintaining

minimum SOC threshold limit. Figure 5.5 shows active and reactive power provided by EV battery and AC-DC converter's DC-link, respectively, according to user defined signals.

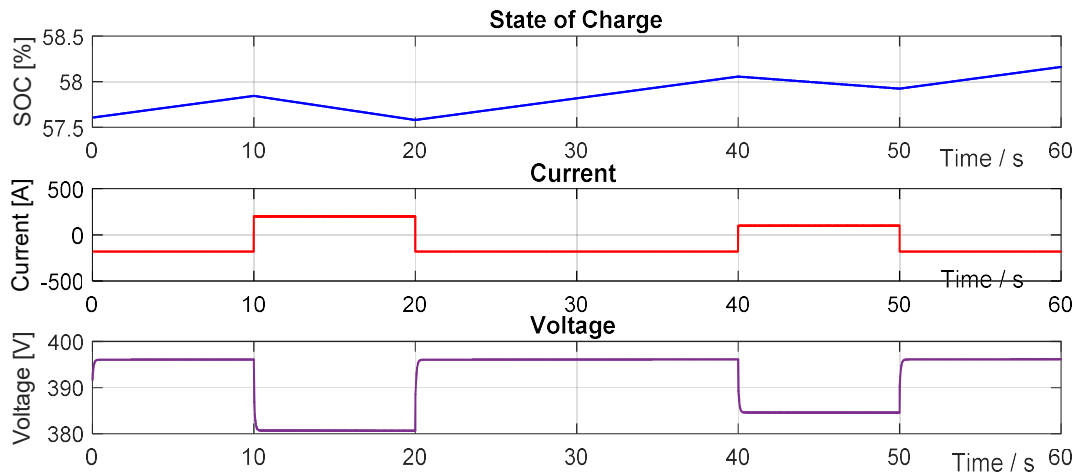

Figure 5.4: EV battery status after simulation

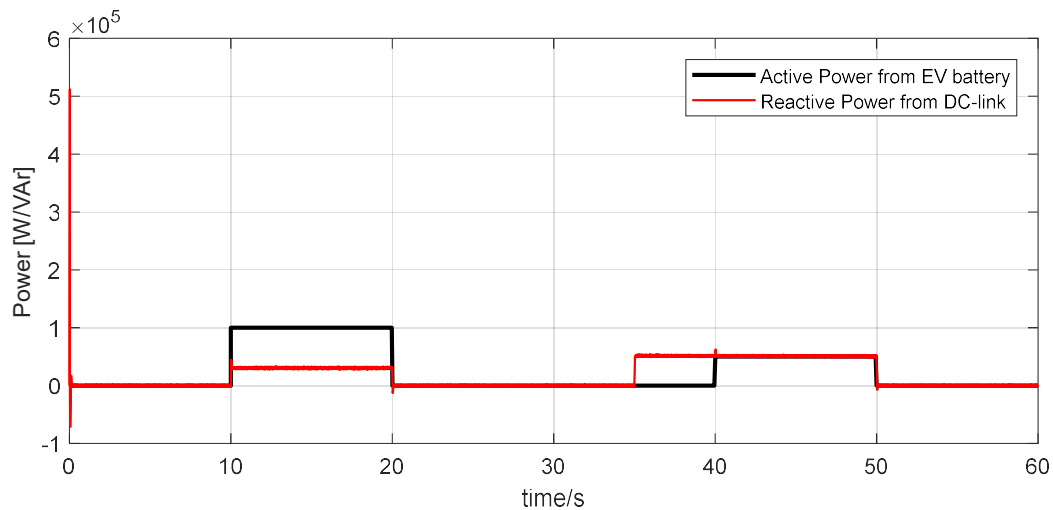

Figure 5.5: Power provided to utilities

Table 5.3 Simulation parameters of case study A

Parameter	Value
Simulation time	60 seconds
Charging currents	180A [20%-60% SOC], 105A [60%-80% SOC], 10A [80%-100% SOC]
SOC threshold	40%

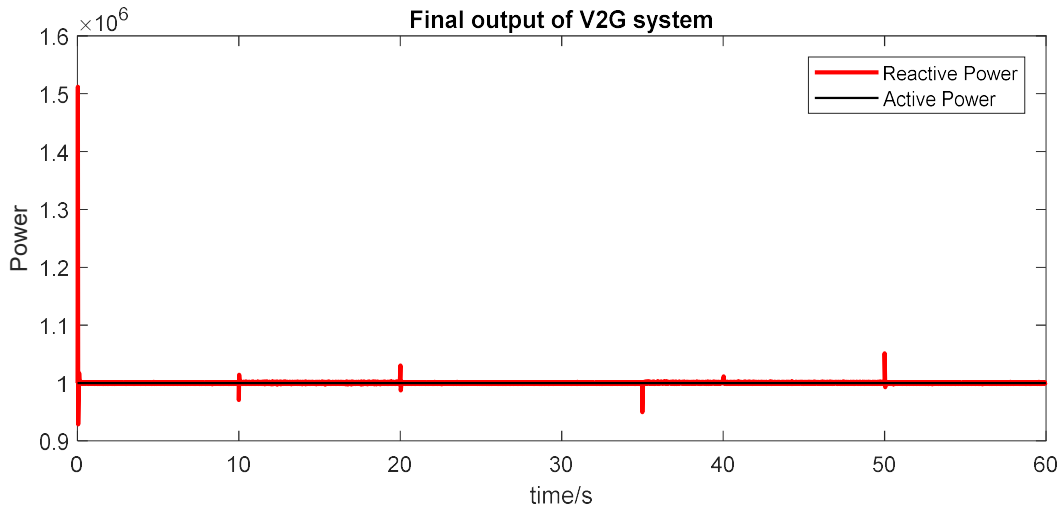

Figure 5.6: Utility demand signal after V2G

Finally, sum of Figure 5.3, that is, utility demand signal, and Figure 5.5, power provided by EV batteries (active power) and AC-DC converter's DC-link (reactive power), is presented in Figure 5.6. It can be seen, during intervals of demanded power by utility, V2G system developed in this study provides required power to utility quite accurately. This verifies working model of V2G infrastructure designed in chapter 3.

5.1.2 Case B – peak shaving

After achieving successful results from case A, working model of V2G infrastructure, test model in case study B is created to show potential peak shaving and load leveling services EV batteries can provide to utilities.

Case study B is formulated using integrator model of EV batteries in MATLAB Simulink. The model charges EV batteries during off-peak hours and discharges EV batteries for peak shaving during hours of high power demand, during a period of 24 hours. Charging and discharging of EV batteries is determined by local controller algorithm. The parameters for EV battery used in this study are same as case A, except, battery model in this case study refers to a collective model of batteries from EV fleet connected with utility in a certain region. Furthermore, results obtained from case study B create an understanding of results expected from optimization techniques

discussed and formed in chapter 4. Table 5.4 shows simulation parameters used to create model of V2G infrastructure in case study B. It is to be noted that test model created in case study B is for a vehicle-to-building (V2B) scenario. Figure 5.7 shows typical load profile of building considered in this case study.

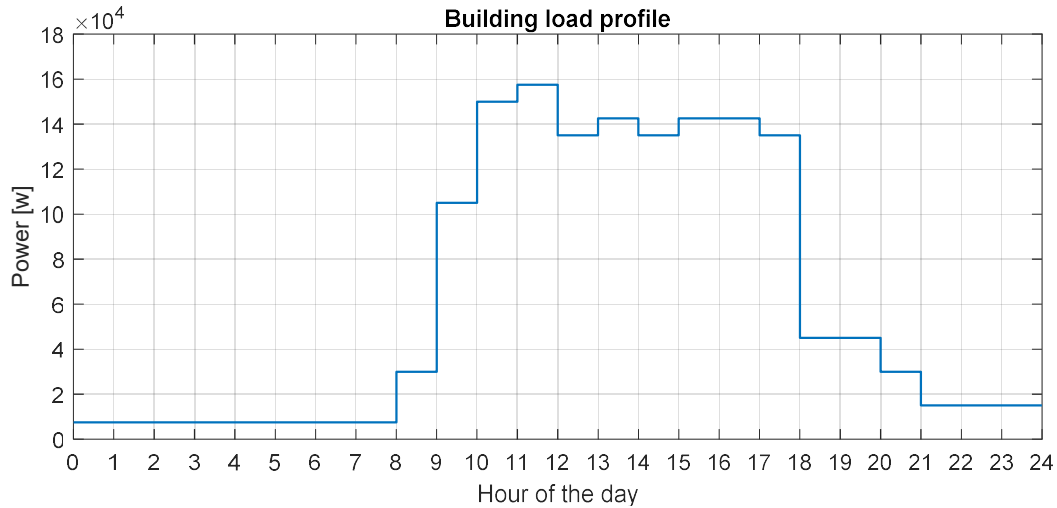

Figure 5.7: Load profile of building

From Figure 5.7 it can be seen that, for successful V2G operation EV batteries must charge in time between 21:00 to 08:00 hours. In addition to that, EV batteries should provide power to utilities between 10:00 and 18:00 hours for peak shaving purpose. State of charge of EV batteries involved in this case study is presented as a collective in Figure 5.8. Furthermore, Figure 5.9 shows charging power of EVs involved in this case study for V2B setup.

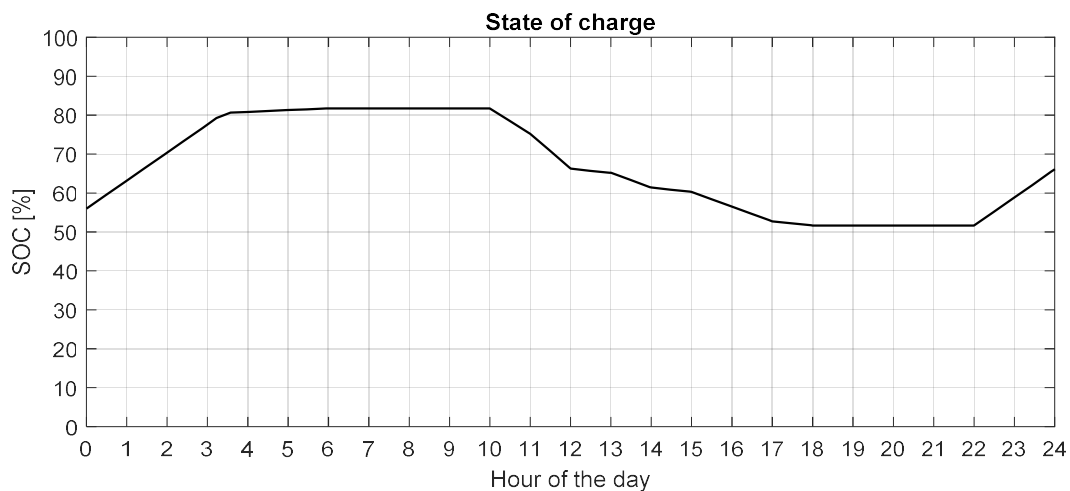

Figure 5.8: Collective SOC of EV batteries

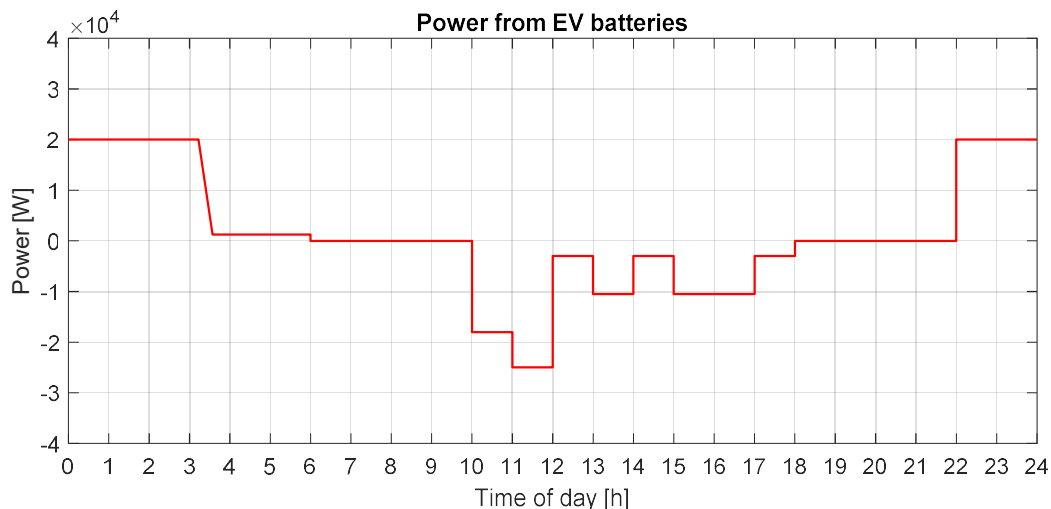

Figure 5.9: Power stats of EV batteries involved in V2B

Finally, Figure 5.10 provides successful results of V2B operation constructed in case study B. It can be seen in Figure 5.10 that EV batteries are providing power to utilities during peak power demand hours, reducing power demand. Besides, EV batteries are charging during off-peak hours to level utility power demand, instead of adding extra load on grid during peak load hours.

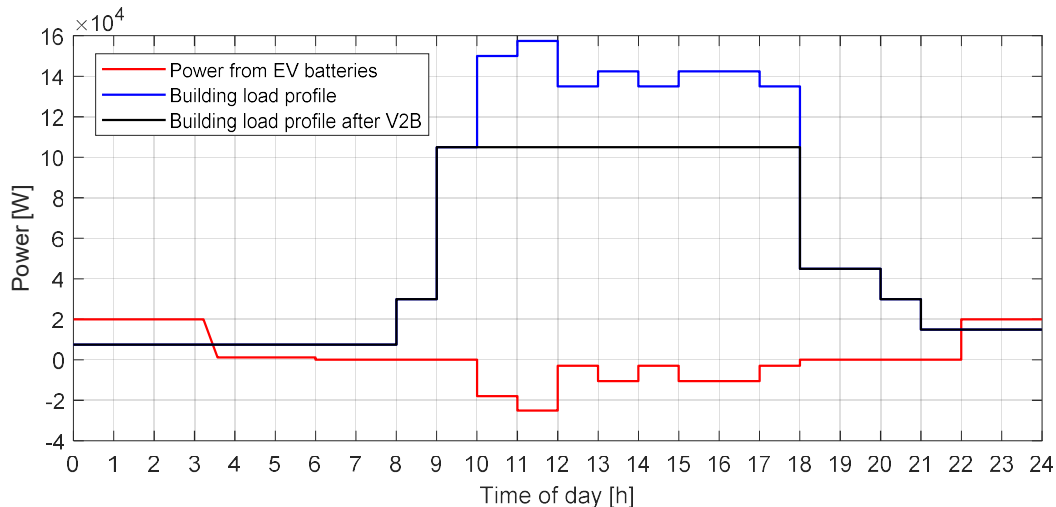

Figure 5.10: Data after V2B simulation

From results obtained in Figure 5.10, it can be seen that overall utility load is reduced during peak hours and EV batteries are charging during off-peak hours. This sample test model, developed in this case study, has provided an idea of results expected from optimization models developed in chapter 4. The next sections of this chapter develop case studies around optimization models to achieve desired results.

Table 5.4 Simulation parameters and specifications

Parameter	Values
Simulation time	86400 seconds (24 hours)
Number of cars	1
Max. charging current	125A
DC Voltage	500V
Reference electric car	Tesla Model S
Capacity	85 kWh

5.2 Optimization results

From previous case studies A and B, working model of V2G system is verified and an understanding of ancillary services expected from EVs in V2G scenario in this study is developed. The next objective of this study is to devise smart charging schedules for optimal charging and discharging of EV batteries.

Chapter 4 elaborated four optimization models formulated in this study to address problems of charging and discharging EVs, without smart charging schedule, in two different scenarios; regional load control and area load control. This section of study formulates four case studies to verify accuracy of optimization models created in chapter 4 to achieve peak power shaving and load leveling, using EV batteries to support utilities.

Case study C achieves peak load shaving and load leveling in regional load control scenario. Case study D, E and F achieve desired results in area load control strategy.

5.2.1 Case C – regional load control

This case refers to regional load control, meaning, optimization is performed on overall utility load profile. In this case, load profile is a sum of residential, industrial and commercial loads over a period of 24 hours. Utility load profile of region used in this case is shown in Figure 5.11.

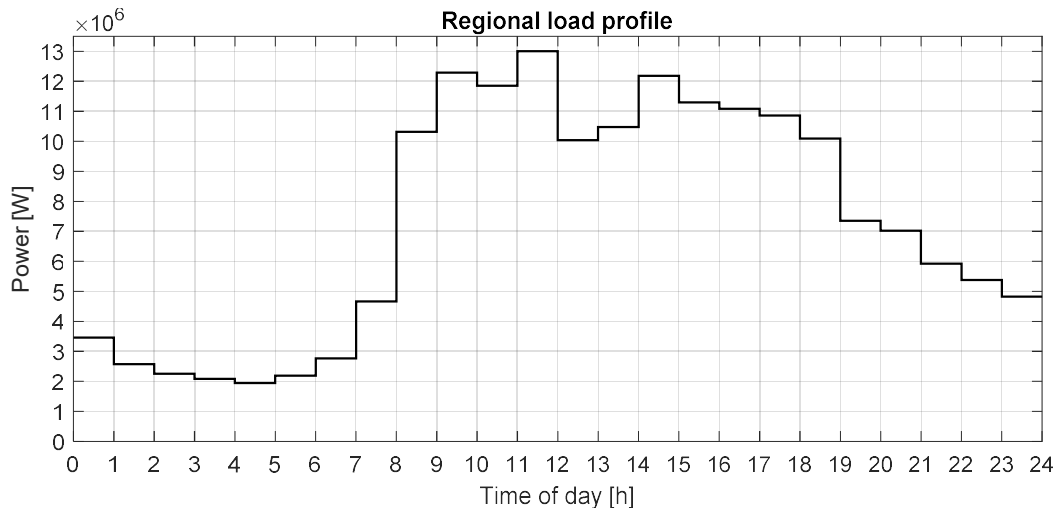

Figure 5.11: Utility load profile

In this case, it is assumed that all EVs available in a region are participating in V2G scenario. Another assumption that is made to formulate this case is that EVs are plugged in. A fleet consisting of total 26 EVs is taken to perform optimization in this case. 8 EVs each in residential and industrial area and 10 EVs in commercial area. Each time interval consists of 1 hour and a total of 24 hours are taken to analyze charging and discharging behavior of EVs in this case. The data taken for EVs and charging systems is according to latest developments and standards in EV charger industry. The list of parameters used in this case is given below:

- Battery energy capacity b_i for each EV is chosen to represent EVs available in market today and fleet of EVs is a mixture of average to higher end EV types available. Further, to implement optimization a much higher capacity is taken as a collective some of all EV batteries in one area. For instance, one capacity representing all EV batteries in residential area and similarly one each for commercial and industrial area.

- EV batteries initial state of charge (SOC) around midnight, 24:00, is taken as 80% because in this case it is defined that EV batteries charge with maximum charging current for fast charging, given EVs start charging as soon as they arrive home due to low power demand during those hours.
- Charging and discharging is assumed to be fast charging to charge EVs in minimum time for SOC between 20% - 80%. From 80% - 100%, slow charging is deployed to top battery with full state of charge (can be observed between 24:00 and 07:00 according to assumptions made).
- Since, EVs in different areas have different requirement of travel, threshold SOC set for EVs in each area is defined over a different time interval. Residential EVs must have a minimum of 55% SOC at 16:00 hours. EVs in commercial areas must have minimum of 60% SOC by 18:00 and EVs in industrial area must maintain a minimum of 60% SOC by 17:00 hours. The times chosen for these scenarios are based on assumption that EV owners need to derive home from work or go out for household chores at those hours.
- Further, in this study fast charging is taken into consideration and it is assumed that vehicles are plugged in as soon as they can. For this reason, a criterion of reaching 80% SOC is used by midnight to support fast charging for all vehicles. After midnight, the charging slows down to top the battery to maximum allowed SOC limit in this study.
- Maximum allowed SOC for each EV in this case is given a value of 0.90 representing 90%. This is assumed to keep battery health in consideration. Alternatively, for same purpose minimum SOC allowed for each EV is chosen to be 20% (0.20).
- Maximum charging current allowed for each EV is chosen 125A, as per typical CHAdeMO standards for fast charging. Similarly, minimum charging current, discharging current in this study, chosen is -125.
- In this case, it is also chosen to take charging power and currents to be positive and discharging power and currents to be negative for better understanding and analysis of results obtained.
- Since, the objective of study is to develop fast charging strategy, DC voltage chosen for optimization in this case is 500V, as per DC fast charging levels.

Table 5.5 shows values chosen, to implement this case, for all variables defined and used in chapter 4.3.

Table 5.5 Parameters and values used in optimization

Parameter	Value
Max. discharging current: $I_i^{c,min}$	-125A
Max. Charging current: $I_i^{c,max}$	125A
State of charge: S_i^{min}	0.2 (20%)
State of charge: S_i^{max}	0.9 (90%)
State of charge threshold: $S_{desired}$	0.55 (55% for residential EVs), 0.60 (60% for industrial and commercial EVs), 0.80 (80% for all EVs)
Desired time for $S_{desired}$: $t_{desired}$	16:00 for residential, 17:00 for industrial and 18:00 for commercial EVs, 00:00 for all EVs
Max. discharging power: C^{min}	- 1500 kW for residential area - 51.8 kW for commercial area - 600 kW for industrial area
Max. Charging power: C^{max}	1500 kW for residential area 51.8 kW for commercial area 600 kW for industrial area
Total number of time steps	24
Utility base power	13 MW

Quadratic programming is used to implement optimization problem developed in chapter 4.3 for regional load control. Results obtained from regional load control optimization for optimal charging schedule are presented in Figure 5.12 to Figure 5.15.

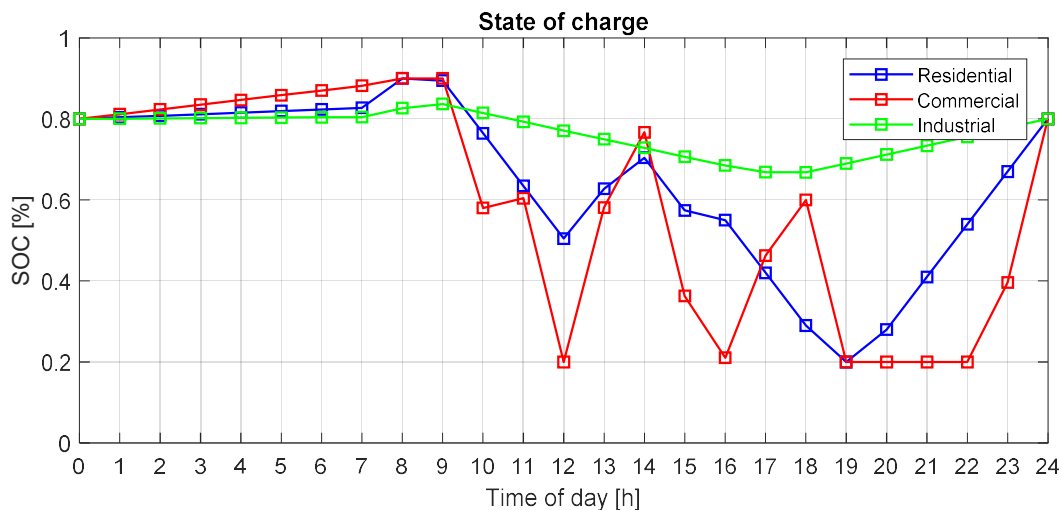

Figure 5.12: Collective state of charge of EVs in different areas of region

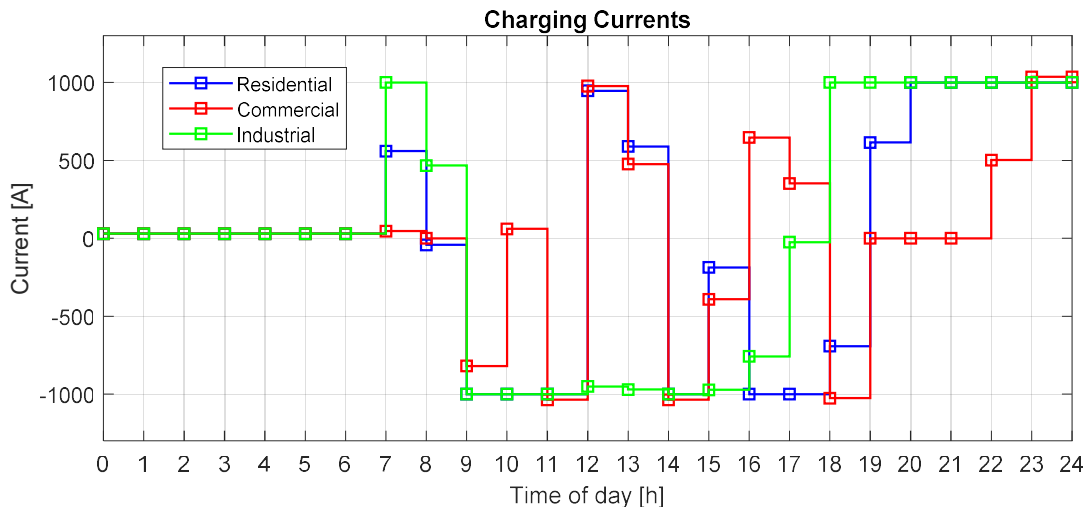

Figure 5.13: Collective charging currents in different areas of region

From Figure 5.12, it can be seen that, desired SOC for each region at a desired time (user defined), is maintained keeping SOC always within limits. Moreover, it can also be observed that EVs are charging to maximum point when utility power is available in off-peak load hours. Figure 5.13 and Figure 5.14 show that EVs in each region are charging with maximum charging current and

charging power when power is available (off-peak time) during the day, staying within their defined limits achieving accurate results.

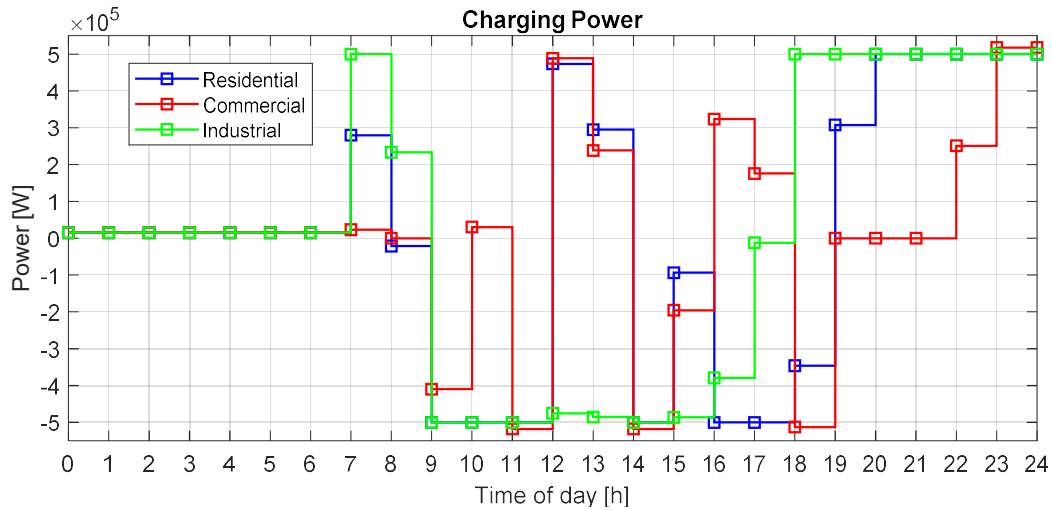

Figure 5.14: Collective charging powers of different areas in region

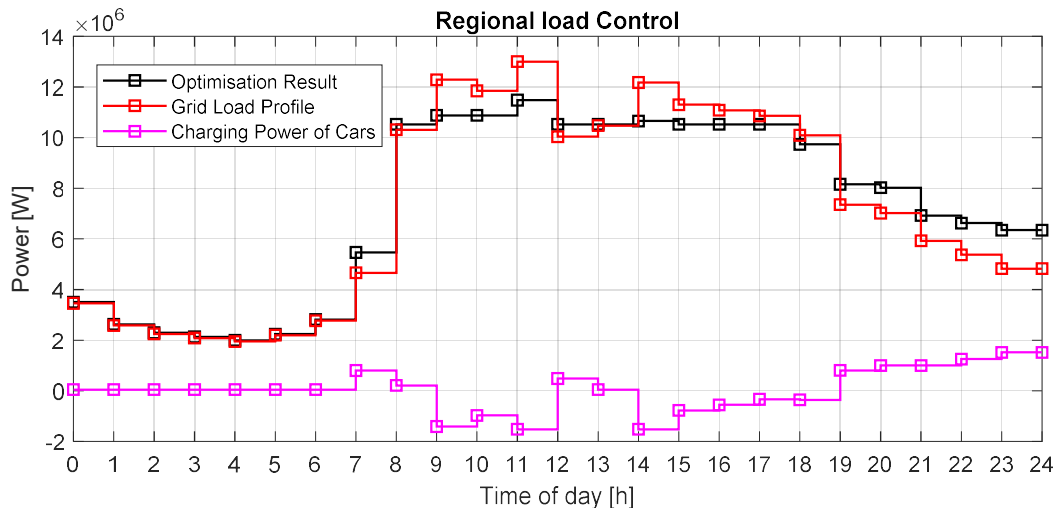

Figure 5.15: Optimization results of regional load control

Finally, Figure 5.15 verifies results expected of regional load control optimization model formulated in chapter 4.3. EVs are charging during off-peak power demand hours of the day, between 19:00 – 07:00. Similarly, EV batteries are providing utilities with active power support for peak power shaving during high power demand hours, that is, between 09:00 - 19:00 hours. The results obtained from quadratic optimization achieve significant power reduction during peak times. It can be seen in Figure 5.15 that peak power from 13 MW is reduced to approximately 11.5 MW with a reduction of almost 1.5 MW. The average power is approximately 7.33 MW after

optimization and standard deviation of approximately 3.56 MW, as compared to standard deviation of 3.973 MW before optimization.

5.2.2 Case D – residential load scheduling

In this case, quadratic programming is implemented to find optimal charging solution for residential load control designed in chapter 4.4.1.

Variables used in this case are the same as case study C for a clear comparison of all cases. The list of parameters used to implement this case is presented in Table 5.6. Results obtained from quadratic optimization for residential load scheduling developed in chapter 4.4.1 using parameters in Table 5.6 are presented in Figure 5.16 – Figure 5.19.

Table 5.6 Parameters used in case study D

Parameter	Value
Max. discharging current: $I_i^{c,min}$	-125A
Max. Charging current: $I_i^{c,max}$	125A
State of charge: S_i^{min}	0.2 (20%)
State of charge: S_i^{max}	0.9 (90%)
State of charge threshold: $S_{desired}$	0.55 (55%) 0.80 (80%)
Desired time for $S_{desired}$: $t_{desired}$	16:00 00:00
Max. discharging power: C^{min}	-500 kW
Max. charging power: C^{max}	500 kW
Total number of time steps	24
Residential base power	6 MW
Number of EVs	8

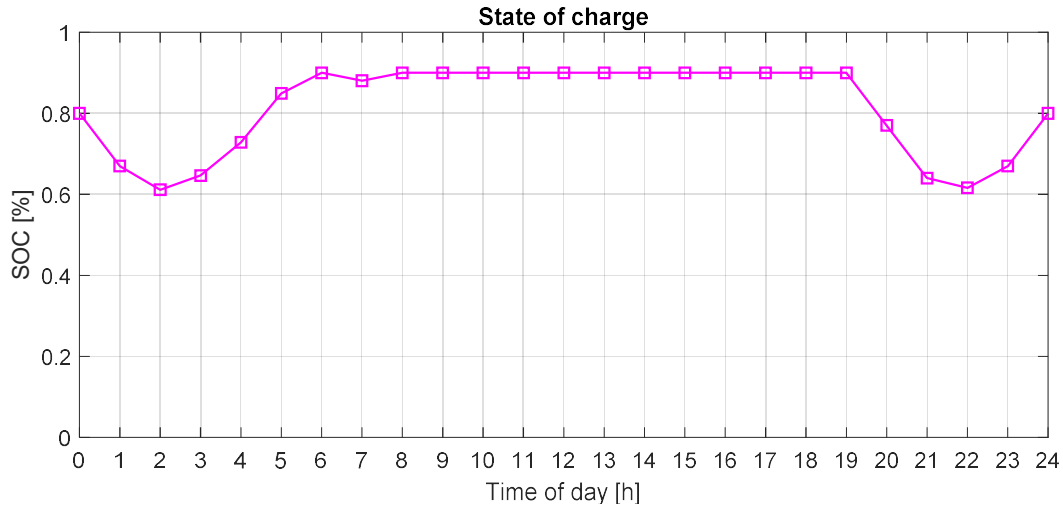

Figure 5.16: Collective SOC of EVs in residential area

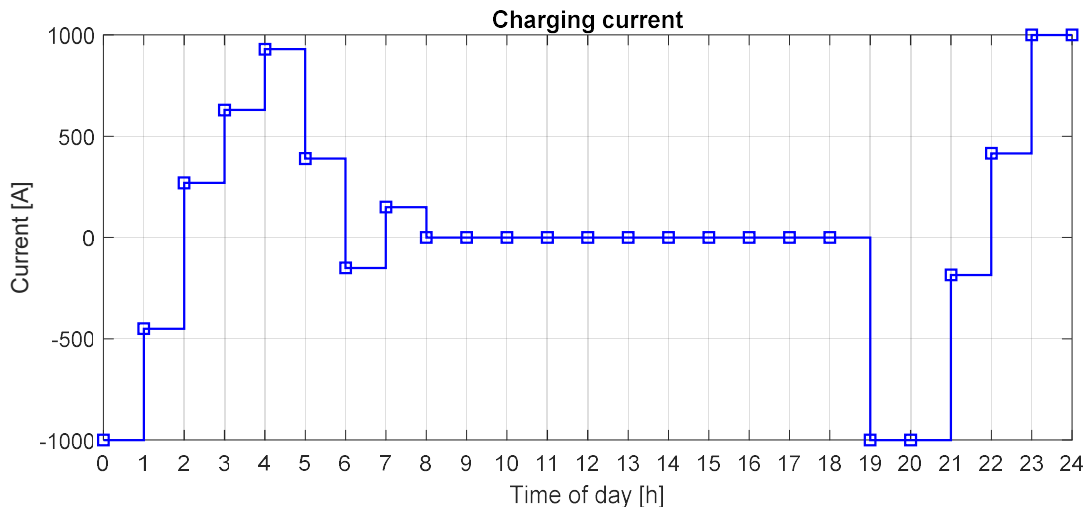

Figure 5.17: Collective charging current of EVs in residential area

Figure 5.16 shows collective SOC graph of EVs in residential area participating in V2G scenario. It can be seen that quadratic optimization implemented achieved desired results. EV batteries are discharging during peak load times in residential area to minimize peak load, resulting in peak power shaving for utilities. On the other hand, EV batteries are charging during off-peak hours to reduce added load for utilities, resulting in load leveling.

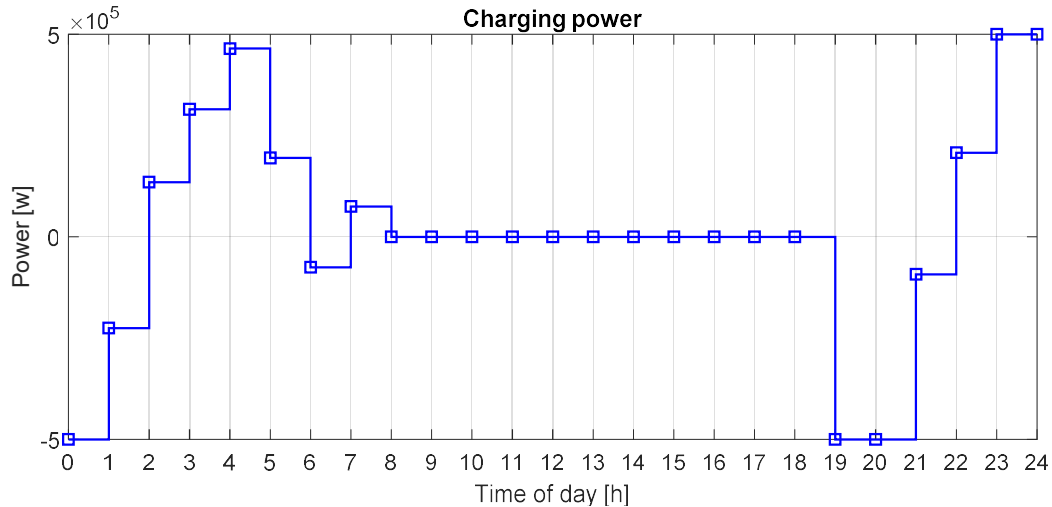

Figure 5.18: Collective charging power of EVs in residential area

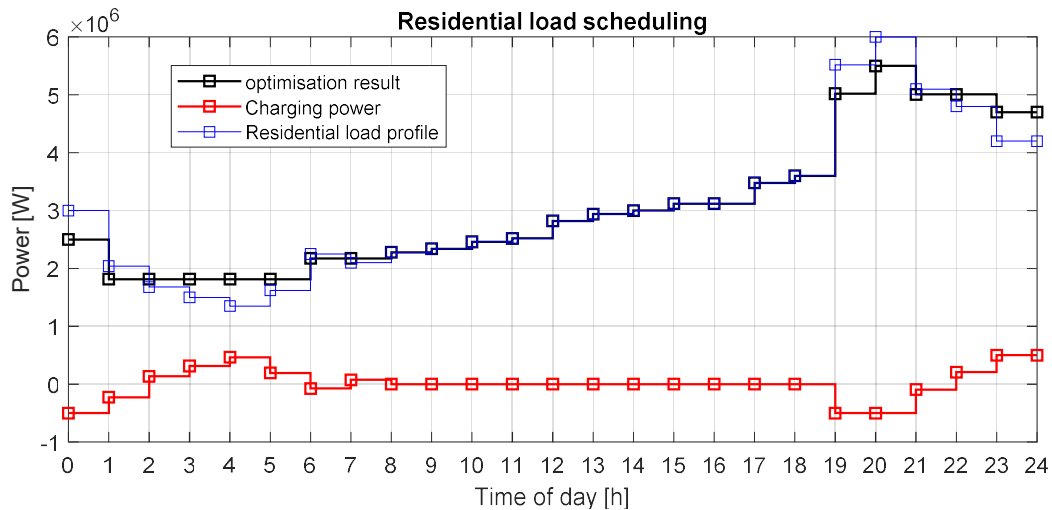

Figure 5.19: Optimization results of residential load scheduling

Figure 5.17 and Figure 5.18 further support the argument by presenting charging current and charging power for EVs in residential area. Maximum discharging current and discharging power is observed during peak hours. Power is taken from utilities during off-peak hours to level load profile of utility in residential area as much as possible. Finally, Figure 5.19 shows optimization results. The overall utility power demand is reduced in peak times because EV batteries are supporting utilities with active power support, particularly between 19:00 - 01:00 hours. The peak power is reduced by 500 kW, from 6 MW to 5.5 MW. The standard deviation and average power of optimized results in this case are, 1.18 MW and 3.1 MW respectively. As compared to standard deviation of 1.28 MW before optimization.

5.2.3 Case E – industrial load scheduling

In this case quadratic programming is applied to optimization problem formulated in chapter 4.4.2 for industrial load scheduling. Variables used in this case are the same as case study C and case study D for better understanding. However, values assigned to variables are different, as per requirements of this case. Table 5.7 shows variables used and values assigned to implement quadratic optimization for verification of results obtained in case study E.

Table 5.7 Parameters and values used in case study E

Parameter	Value
Max. discharging current: $I_i^{c,min}$	-125A
Max. charging current: $I_i^{c,max}$	125A
State of charge: S_i^{min}	0.2 (20%)
State of charge: S_i^{max}	0.9 (90%)
State of charge threshold: $S_{desired}$	0.60 (60%) 0.80 (80%)
Desired time for $S_{desired}$: $t_{desired}$	16:00 00:00
Max. discharging power: C^{min}	-800 kW
Max. charging power: C^{max}	800 kW
Total number of time steps	24
Residential base power	4 MW
Number of EVs	12

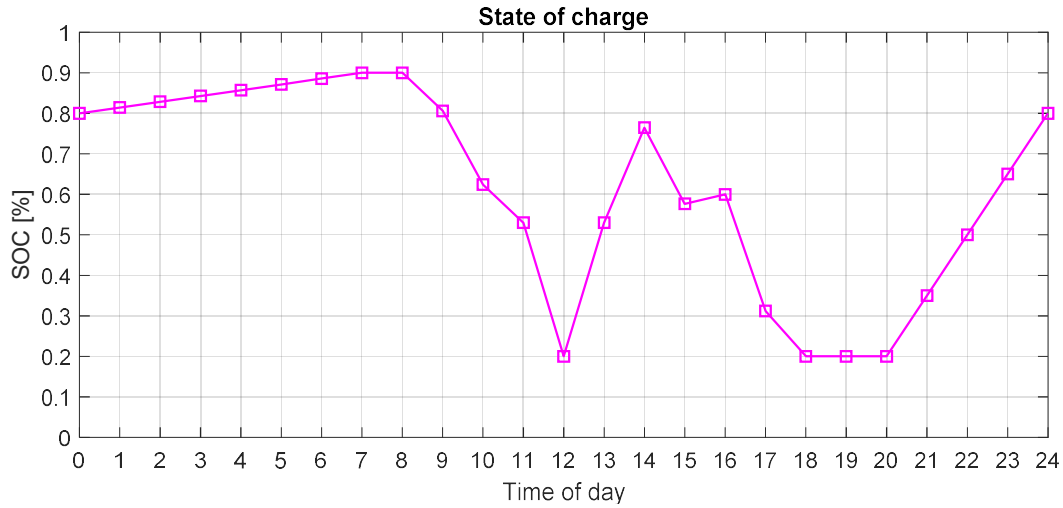

Figure 5.20: Collective SOC of EVs in industrial area

Figure 5.20 presents SOC of EVs participating in optimal scheduling for industrial load control. It can be seen in the figure that EV batteries are maintaining required SOC at defined intervals, as per EV owners demand. Moreover, EV batteries charge when power demand is low in commercial area. Similarly, EV batteries are charging during off-peak hours which satisfies constraints, as well as, objective function defined in this case.

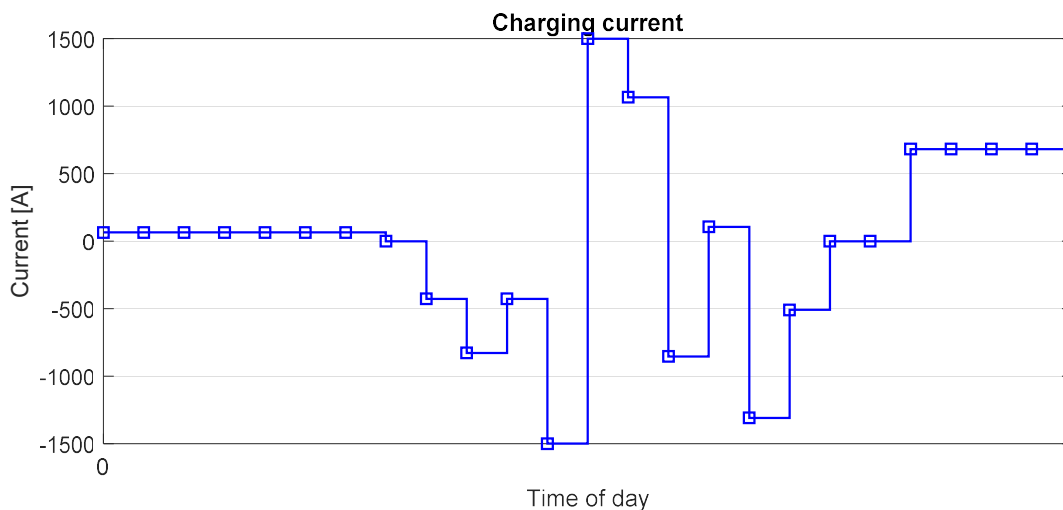

Figure 5.21: Collective charging current of EVs in industrial area

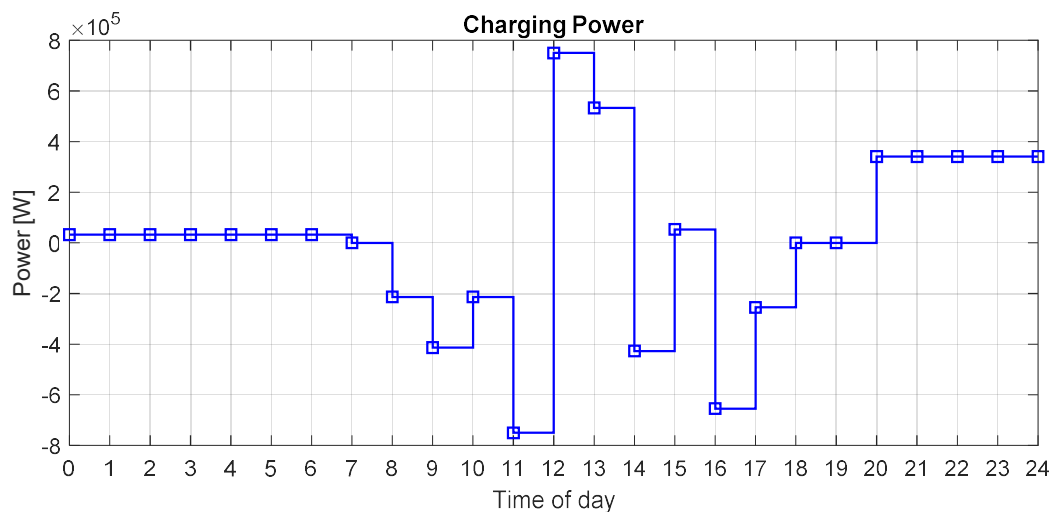

Figure 5.22: Collective charging power of EVs in industrial area

Figure 5.21 and Figure 5.22 provide status of charging current and charging power given to EV batteries for charging and power taken from EV batteries to support utilities with active power support. Charging power is drawn from grid to charge EV batteries during off-peak hours, as well as, maximum power available in EV batteries is provided to utilities to reduce peak power demand, in this case between 08:00 -12:00 and then again between 13:00 -16:00 hours.

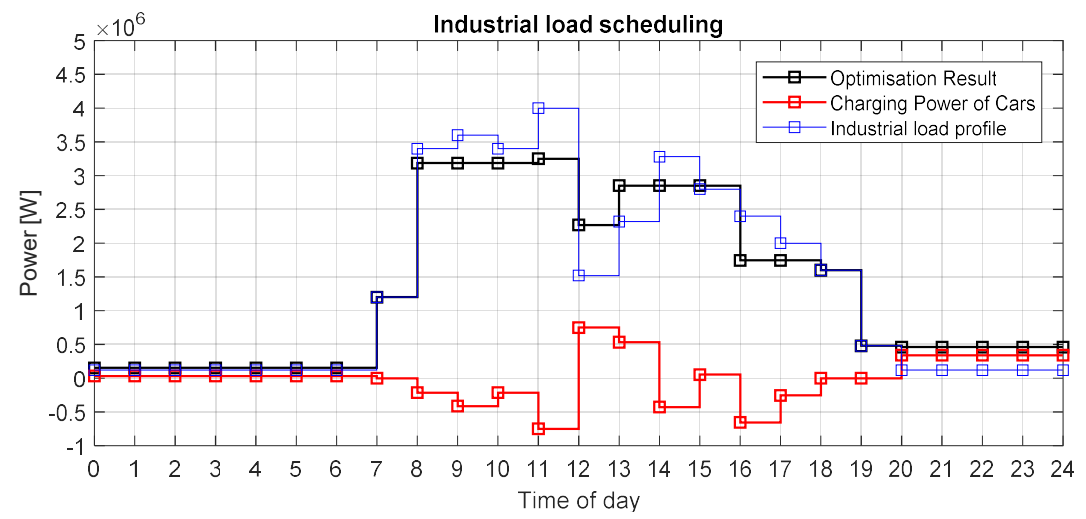

Figure 5.23: Optimization result of industrial load scheduling

Finally, from optimization results seen in Figure 5.23, objective function formulated in chapter 4.4.2 gives an optimal charging schedule by minimizing utility power demand over periods of high power load. This case also verifies optimization model devised for industrial load scheduling with a peak power reduction of 750 kW, from 4 MW to 3.25 MW for an average power of 1.4MW. The standard deviation before optimization was 1.42 MW, whereas, standard deviation achieved after optimization is 1.25 MW.

5.2.4 Case F – commercial load scheduling

In this case, optimal charging schedule for EVs in commercial area is formulated using variables and values presented in Table 5.8.

Table 5.8 Values and parameters for commercial load scheduling

Parameter	Value
Max. discharging current: $I_i^{c,min}$	-125
Max. charging current: $I_i^{c,max}$	125A
State of charge: S_i^{min}	0.2 (20%)
State of charge: S_i^{max}	0.9 (90%)
State of charge threshold: $S_{desired}$	0.60 (60%)
	0.80 (80%)
Desired time for $S_{desired}$: $t_{desired}$	16:00
	00:00
Max. discharging power: C^{min}	-700 kW
Max. charging power: C^{max}	700 kW
Total number of time steps	24
Residential base power	5 MW
Number of EVs	8

The objective of this case study is to minimize utility power demand during peak load hours by taking power from EV batteries. Meanwhile, maintaining desired SOC at defined intervals. In addition to reducing peak load for utilities, EV batteries charge during off-peak hours in order to level load in commercial areas. Figure 5.24 to Figure 5.25 present results obtained from quadratic optimization applied to optimal charging schedule modeled in chapter 4.4.3.

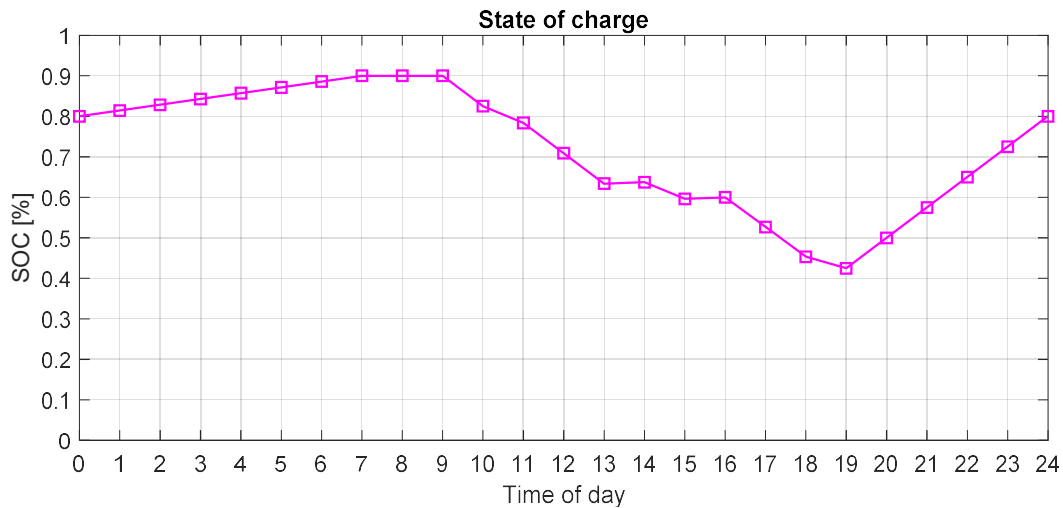

Figure 5.24: Collective SOC of EVs in commercial area

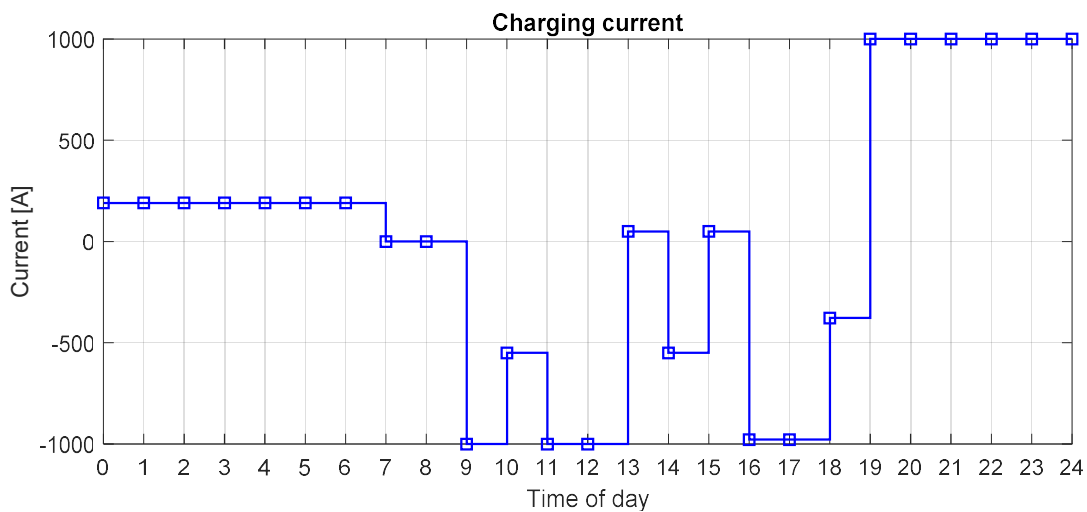

Figure 5.25: Collective current of EVs in commercial area

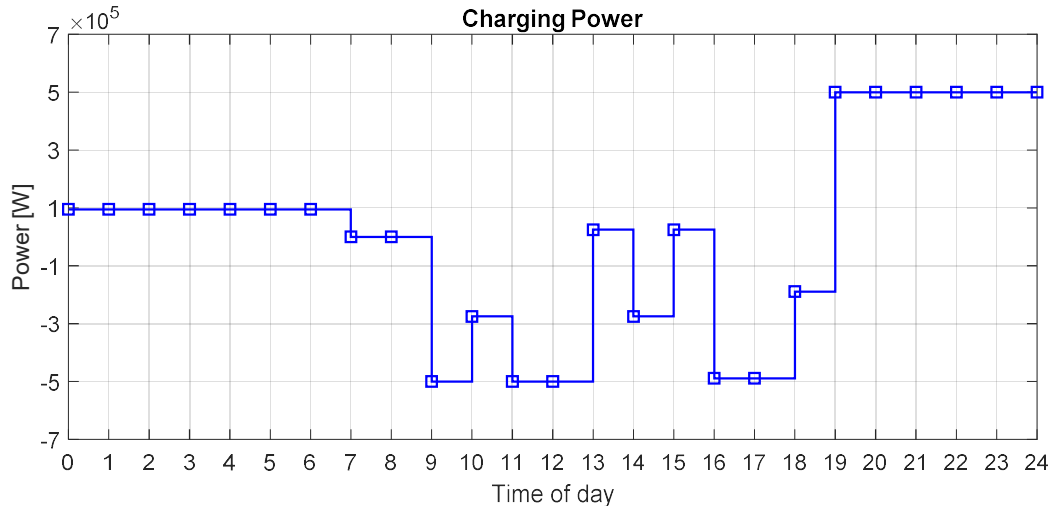

Figure 5.26: Collective charging power of EVs in commercial area

Figure 5.25 and Figure 5.26 provide results of charging current and charging power for EVs in commercial area after optimization. Both charging currents and charging power are within constraints and follow objective function to provide maximum power to utilities during peak load hours and draw maximum charging power to charge EV batteries during off-peak hours.

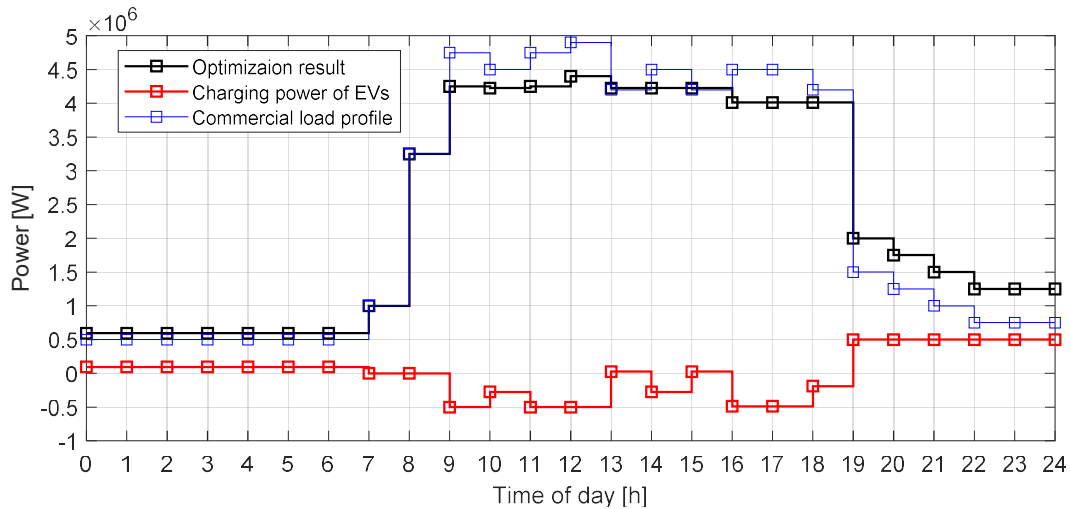

Figure 5.27: Optimization results of commercial load scheduling

Figure 5.27 gives final result of optimization done over commercial load profile and EVs available in commercial area. It can be observed that EVs are providing maximum support to utilities during peak power demand hours, 09:00 - 19:00. Moreover, EV batteries charge during night time when utilities can provide this power without burdening grid for more production to satisfy added load. The optimization model created for commercial load scheduling satisfies objective within

constraints and provide a reduced peak from 4.9 MW in original load profile to 4.4 MW in optimized load profile. Average power after optimization observed in this case is 2.4 MW with a standard deviation of 1.64 MW, as compared to a standard deviation of 1.89 MW before optimization.

5.3 Cost analysis

In this section of the study cost analysis is done to support the argument based on results obtained after optimization methods implemented in this study, to reduce cost for utilities and EV owners.

The cost analysis is based on power tariff that commercial and industrial sector has to pay in addition to energy consumption from electric grid. The cost taken in consideration for this analysis is based on data provided by Nordkraft for supply area of Nordkraft Nett AS (Narvik Municipality and the Wall of the Municipality of Evenes) [54].

The power load profile, of commercial and industrial areas, remains within close proximity of data presented in this chapter throughout the year. Therefore, for cost analysis, load profiles for commercial and industrial areas with and without optimization are used to determine minimized cost. It is observed from [54] that industrial and commercial areas have to pay a huge amount of money for consumption of power per kilo Watts (kW) in addition to energy prices. These power tariffs can be minimized if power is taken from EV batteries during off peak hours to reduce peak load demand, which will benefit both utilities and EV owners. It is to be noted here that, these power tariffs do not apply to residential areas as of now, but according to new methods adopted by distribution companies, there will be power tariffs for residential areas in near future. This will further motivate to implement smart charging schedules to reduce cost of consumed electric power. Cost of power consumption before and after optimization techniques implemented in this study are presented in Table 5.9 to support the argument. The cost analysis is done over peak power period of the day

Table 5.9 Cost reduction after smart scheduling strategy

	Commercial area	Industrial area
	(12:00 – 13:00)	(11:00 – 12:00)
Power consumption before optimization [kW]	4900	4000
Power consumption before optimization [kW]	4400	3250
Power reduced [kW]	500	750
Power tariff before optimization [NOK]	1.9894 million	1.624 million
Power tariff after optimization [NOK]	1.7864 million	1.3195 million
Cost reduction [NOK]	0.203 million (203,000)	0.3045 million (304,500)

The figures in Table 5.9 support the accuracy of optimization technique adopted in this study to reduce cost. The reduced power tariff, because of low power peak, reduces consumer cost and it also saves investment cost of utilities if they don't intend to upgrade distribution system for new EV loads. In summary, the significant savings verify the need of smart scheduling strategies as EVs multiply manifolds in near future. Otherwise, instead of savings, owners of EVs and utilities will have to pay a lot more money to meet power demand with added EV load on electric grid.

5.4 Discussion of results

The two objectives of this study were to first, develop a charging infrastructure for state-of-the-art V2G system using fast charging technology. Second, to formulate smart charging schedule for

EVs to participate in V2G scenario, such that, cost of charging is minimized for electric utilities and EV owners.

Model created in MATLAB Simulink for integrating EVs with electric grid and utilities achieves the first objective. From results obtained in case study A, it is deduced that EV batteries are charging and discharging as per utility requirement, as well as, EV owners' desire. The results prove that model created in chapter 3 is an efficient model with fast charging ability to charge EVs maintaining desired SOC of EV batteries. Simultaneously, local controller algorithm designed in this study discharge EVs efficiently and provide active and reactive power support to utilities, as per demand signals received. The sum of demand signal, reactive power injected by AC-DC converter's DC-link and active power provided by EV batteries balance utility's reference power by filling the gaps accurately in demand signal.

Further, optimization models created to implement quadratic programming using MATLAB code effectively satisfied second objective of this study, that is, smart charging schedule for charging EV batteries. The optimization models created in chapter 4, when implemented using parameters defined in case studies C, D, E and F, accomplish peak power shaving and load leveling by charging EV batteries with maximum power when utility's power demand is low in areas. Concurrently, models smartly provided active power support to utilities for peak power shaving during times of day when power demand is at its peak.

The proposed models in this study achieve desired goals while maintaining constraints set by EV owners and utilities. The results obtained seem promising to pursue V2G implementation to benefit from increasing EV market. Cost analysis in this chapter further support the argument by showing that optimal charging schedule, implemented in this study, minimizes charging cost for EV owners and is profitable for utilities. Consumers will have to pay less power tariff due to low peak power and at the same time, it saves huge investment on utility's side by not upgrading their system.

To sum up, the models created in this study and results obtained from these models, it is evident that utilities and EV owners can benefit from V2G scenario. EV owners will be given incentives to support utilities with power demand which will reduce cost of charging. In addition, charging in off-peak hours will reduce power tariff to a much lower amount which is another advantage of V2G for consumers. On the other hand, utilities have a lot of advantages that can be yielded from

V2G scenario. First, load leveling causes grid stability and doesn't require investment in generation side. The added load of EVs can cause negative impacts on grid health and these impacts can be reduced to almost none by participating in V2G. In addition, participating in V2G allows utilities to reduce power demand on consumer end, which doesn't put an extra load on grid and keeps grid reliability and stability to an optimum level. Most importantly, EV numbers are growing rapidly and they seem to go up in near future. By participating in V2G scenario, utilities will not have to upgrade their system to meet added EV load on distribution network, which is a great advantage for utilities. Otherwise, with increasing number of EVs, not only day-to-day generation capacity needs to be increased, utilities will have to upgrade their entire system to meet this additional load of EVs connected in distribution network.

6 Conclusion and Future Work

6.1 Conclusion

The concerns related to greenhouse gas (GHG) emission and pollutants in environment due to traditional fossil fuel burning internal combustion engine vehicles (ICEVs) have alarmed nations worldwide to come up with technology to mitigate these adverse environmental effects. Electric vehicles (EVs) seem a promising solution to these issues. However, increased adoption of EVs worldwide due to technological advances in recent years has raised concerns regarding electric grid health and negative impacts of integrating EVs into power systems distribution network.

In order to encourage higher adoption of EVs this study develops fast charging infrastructure to satiate EV owner's anxiety, as well as, smart charging schedule to mitigate adverse effects of integrating large fleet of EVs in distribution network, in addition to alleviating environmental concerns. The contribution of this study is two-fold. First, DC fast charging station using state-of-the-art V2G technology is explicitly modeled in order to reduce charging time as much as possible. Second, smart charging scheduling is modelled in detail to minimize the cost of charging for electric utilities and EV owners.

Particularly, MATLAB Simulink is used to implement and verify V2G infrastructure using grid side controller and local controller (aggregator in this study). Further, quadratic programming model is employed to optimize EV charging schedule. The objective is to minimize cost of charging for utilities and EV owners. Considerations are given to state of charge for EV batteries, utility power demand, charging and discharging power of EV batteries, and centralized optimization strategy with 'regional load control' and 'area load control'.

The results obtained from Simulink model of charging infrastructure implemented in this study verify proposed model. It provides sufficient power to EV batteries for charging and takes into consideration when EV owners desire to participate in V2G scenario. In addition, it provides active and reactive power support to utilities while maintaining SOC of EV batteries according to EV owners' demand.

Optimization models formulated in this study to implement quadratic programming for the purpose of reducing cost of charging are also verified by results obtained. The results show that proposed scheduling strategy in this study maintains EV owner's pre-defined SOC at a particular hour after providing services to utilities. Besides, proposed charging schedules level utility load by charging EV batteries in off-peak hours, when utility load is minimum during the day. Concurrently, discharging EV batteries to support utility by providing peak power shaving services using available power in EV batteries.

Lastly, cost analysis of charging and discharging power of EV batteries in this study's optimization model confirmed minimized charging cost for EV owners' and utilities, by reducing peak power which leads to a much lower power tariff. This saves consumers a lot of money and at the same time allows utilities to avoid large investment to upgrade their system in order to meet new power demand, with additional EV load on distribution network.

6.2 Future work

Future work regarding proposed technology in this study can be oriented towards integration of renewable energy resources, in addition to V2G technology, into power systems network. Furthermore, economical aspects of practical implementation of DC fast charging stations for large scale adoption of EVs can be explored.

In smart scheduling strategy area, there are several areas that can be explored for future work. For instance, meta-heuristics to improve solutions of rolling horizon heuristics can be studied. There are several optimization techniques to optimally schedule EV battery charging which can be combined to form hybrid algorithms for best achievable results. The most interesting and

promising study that can be integrated with this study in future work can be, integration of control-based constraints in charging scheduling models to guarantee electric grid stability.

References

- [1] F. Lambert, "Norway is reaching tipping point for electric vehicles as market share reaches record breaking 37%", Electrek, 2017. [Online]. Available: <https://electrek.co/2017/02/15/norway-electric-vehicle-market-share-record>. [Accessed: 20- Apr- 2017].
- [2] "Environmentally Sustainable Transportation Systems - Government Relations - SAE International", Sae.org, 2017. [Online]. Available: <http://www.sae.org/about/government/environmentally-sustainable-transportation-systems>. [Accessed: 21- Apr- 2017].
- [3] "Global ev outlook: Understanding the electric vehicle landscape to 2020", www.iea.org, 2017. [Online]. Available: https://www.iea.org/publications/freepublications/publication/GlobalEVO Outlook_2013.pdf. [Accessed: 21- Apr- 2017].
- [4] K. CZECHOWSKI, "Assessment of Profitability of Electric Vehicle-to-Grid Considering Battery", Graduate, KTH Royal Institute of Technology, 2015.
- [5] W. Kempton, and J. Tomic, Jun. 2005, "Vehicle-to-grid power fundamentals: Calculating capacity and net revenue", J. Power Sources, vol. 144, 268–279
- [6] S. Shao, M. Pipattanasomporn, and S. Rahman, "Grid integration of electric vehicles and demand response with customer choice," IEEE Trans. Smart Grid, vol. 3, no. 1, pp. 543–550, Mar. 2012
- [7] M. Pipattanasomporn, M. Kuzlu, and S. Rahman, "An algorithm for intelligent home energy management and demand response analysis," IEEE Trans. Smart Grid, vol. 3, no. 4, pp. 2166–2173, Dec. 2012.
- [8] M. Ansari, A. T. Al-Awami, E. Sortomme, and M. A. Abido, "Coordinated bidding of ancillary services for vehicle-to-grid using fuzzy optimization," IEEE Trans. Smart Grid, vol. 6, no. 1, pp. 261–270, Jan. 2015.
- [9] K. Hedegaard, H. Ravn, N. Juul, and P. Meibom, "Effects of electric vehicles on power systems in Northern Europe", Energy, vol. 48, pp. 356-368, 2012.
- [10] M. Yilmaz, and Philip T. Krein, "Review of Charging Power Levels and Infrastructure for Plug-In Electric and Hybrid Vehicles", 2012 IEEE IEVC, International Electric Vehicle Conference, 4-8 March 2012.
- [11] Y. He, B. Venkatesh and L. Guan, "Optimal Scheduling for Charging and Discharging of Electric Vehicles", IEEE Transactions on Smart Grid, vol. 3, no. 3, pp. 1095-1105, 2012.
- [12] K. Mets, T. Verschueren, F.D. Turck and C. Develder, "Exploiting V2G to optimize residential energy consumption with electrical vehicle (dis)charging", IEEE First International Workshop on Smart Grid Modeling and Simulation (SGMS) 2011.
- [13] K. Mets, R. D'Hulst and C. Develder, "Comparison of intelligent charging algorithms for electric vehicles to reduce peak load and demand variability in a distribution grid", J Commun Netw, pp. 672–81, 2012.

- [14] B. Sarlioglu, C. Morris, D. Han and S. Li, "Driving Toward Accessibility: A Review of Technological Improvements for Electric Machines, Power Electronics, and Batteries for Electric and Hybrid Vehicles", IEEE Industry Applications Magazine, vol. 23, no. 1, pp. 14-25, 2017.
- [15] J. Yong, V. Ramachandaramurthy, K. Tan and N. Mithulananthan, "A review on the state-of-the-art technologies of electric vehicle, its impacts and prospects", Renewable and Sustainable Energy Reviews, vol. 49, pp. 365-385, 2015.
- [16] "Types of Electric Cars", Ergon Energy, 2017. [Online]. Available: <https://www.ergon.com.au/network/smarter-energy/electric-vehicles/types-of-electric-vehicles>. [Accessed: 27- Apr- 2017].
- [17] "Safety Concerns with Li-ion Batteries – Battery University", Batteryuniversity.com, 2017. [Online]. Available: http://batteryuniversity.com/learn/article/safety_concerns_with_li_ion. [Accessed: 03- May- 2017].
- [18] A. Foley, I. Winning and B. O Gallachoir, "State-of-the-art in electric vehicle charging infrastructure", 2010 IEEE Vehicle Power and Propulsion Conference, 2010.
- [19] "Welcome to 2009, SAE Officially Approves New Fast-Charging Combo: Coupler Standard (SAE J1772) for Plug-In EVs | Inside EVs", Insideevs.com, 2017. [Online]. Available: <http://insideevs.com/welcome-to-2009-sae-releases-new-fast-charging-combo-coupler-standard-sae-j1772-for-plug-in-evs/>. [Accessed: 03- May- 2017].
- [20] S. Wang, R. Crosier and Y. Chu, "Investigating the power architectures and circuit topologies for megawatt superfast electric vehicle charging stations with enhanced grid support functionality", 2012 IEEE International Electric Vehicle Conference, 2012.
- [21] J. Channegowda, V. Pathipati and S. Williamson, "Comprehensive review and comparison of DC fast charging converter topologies: Improving electric vehicle plug-to-wheels efficiency", 2015 IEEE 24th International Symposium on Industrial Electronics (ISIE), 2015.
- [22] C. Weiller, "Plug-in hybrid electric vehicle impacts on hourly electricity demand in the United States", Energy Policy, vol. 39, no. 6, pp. 3766-3778, 2011.
- [23] N. Hartmann and E. Özdemir, "Impact of different utilization scenarios of electric vehicles on the German grid in 2030", Journal of Power Sources, vol. 196, no. 4, pp. 2311-2318, 2011.
- [24] Q. Yan and M. Kezunovic, "Impact analysis of Electric Vehicle charging on distribution system", 2012 North American Power Symposium (NAPS), 2012.
- [25] C. Farkas, G. Szucs and L. Prikler, "Grid impacts of twin EV fast charging stations placed alongside a motorway", 2013 4th International Youth Conference on Energy (IYCE), 2013.
- [26] A. Rautiainen, A. Mutanen, S. Repo, P. Jarventausta, A. Tammi, R. Ryymin, J. Helin, A. Unkuri and M. Pekkinen, "Case studies on impacts of plug-in vehicle charging load on the planning of urban electricity distribution networks", 2013 Eighth International Conference and Exhibition on Ecological Vehicles and Renewable Energies (EVER), 2013.
- [27] R. Bass, R. Harley, F. Lambert, V. Rajasekaran and J. Pierce, "Residential harmonic loads and EV charging", 2001 IEEE Power Engineering Society Winter Meeting. Conference Proceedings (Cat. No.01CH37194).
- [28] C. Jiang, R. Torquato, D. Salles and W. Xu, "Method to assess the power quality impact of plug-in electric vehicles", 2014 16th International Conference on Harmonics and Quality of Power (ICHQP), 2014.
- [29] V. Nguyen, T. Tran-Quoc and S. Bacha, "Harmonic distortion mitigation for electric vehicle fast charging systems", 2013 IEEE Grenoble Conference, 2013.

- [30] O. Onar and A. Khaligh, "Grid interactions and stability analysis of distribution power network with high penetration of plug-in hybrid electric vehicles", 2010 Twenty-Fifth Annual IEEE Applied Power Electronics Conference and Exposition (APEC), 2010.
- [31] C. Dharmakeerthi, N. Mithulananthan and T. Saha, "Impact of electric vehicle fast charging on power system voltage stability", *International Journal of Electrical Power & Energy Systems*, vol. 57, pp. 241-249, 2014.
- [32] Diyun Wu, K. Chau, Chunhua Liu, Shuang Gao and Fuhua Li, "Transient Stability Analysis of SMES for Smart Grid with Vehicle-to-Grid Operation", *IEEE Transactions on Applied Superconductivity*, vol. 22, no. 3, pp. 5701105-5701105, 2012.
- [33] E. Sortomme and M. El-Sharkawi, "Optimal Combined Bidding of Vehicle-to-Grid Ancillary Services", *IEEE Transactions on Smart Grid*, vol. 3, no. 1, pp. 70-79, 2012.
- [34] Y. Zhou and X. Li, "Vehicle to grid technology: A review", 2015 34th Chinese Control Conference (CCC), 2015.
- [35] J. Mukherjee and A. Gupta, "A Review of Charge Scheduling of Electric Vehicles in Smart Grid", *IEEE Systems Journal*, vol. 9, no. 4, pp. 1541-1553, 2015.
- [36] Diyun Wu, K. Chau and Shuang Gao, "Multilayer framework for vehicle-to-grid operation", 2010 IEEE Vehicle Power and Propulsion Conference, 2010.
- [37] M. Kisacikoglu, B. Ozpineci and L. Tolbert, "Examination of a PHEV bidirectional charger system for V2G reactive power compensation", 2010 Twenty-Fifth Annual IEEE Applied Power Electronics Conference and Exposition (APEC), 2010.
- [38] C. Silvestre, D. Sousa and A. Roque, "Reactive power compensation using on board stored energy in Electric Vehicles", *IECON 2012 - 38th Annual Conference on IEEE Industrial Electronics Society*, 2012.
- [39] L. Rauchfuss, J. Foulquier and R. Werner, "Charging station as an active filter for harmonics compensation of smart grid", 2014 16th International Conference on Harmonics and Quality of Power (ICHQP), 2014.
- [40] F. Marra, G. Yang, C. Traeholt, E. Larsen, J. Ostergaard, B. Blazic and W. Deprez, "EV Charging Facilities and Their Application in LV Feeders with Photovoltaics", *IEEE Transactions on Smart Grid*, vol. 4, no. 3, pp. 1533-1540, 2013.
- [41] "Electric Vehicles with V1G and V2G Capabilities", Xanthus-consulting.com, 2017. [Online]. Available: http://xanthus-consulting.com/WIEB/Discussions/346_Electric_Vehicles.html. [Accessed: 09- May- 2017].
- [42] A. Koufakis, E. Rigas, N. Bassiliades and S. Ramchurn, "Towards an optimal EV charging scheduling scheme with V2G and V2V energy transfer", 2016 IEEE International Conference on Smart Grid Communications (SmartGridComm), 2016.
- [43] Y. Ota, H. Taniguchi, H. Suzuki, J. Baba and A. Yokoyama, "Aggregated storage strategy of electric vehicles combining scheduled charging and V2G", *ISGT 2014*, 2014.
- [44] Ming Zeng, Supeng Leng and Y. Zhang, "Power charging and discharging scheduling for V2G networks in the smart grid", 2013 IEEE International Conference on Communications Workshops (ICC), 2013.
- [45] S. Yoon, Kanggu Park and E. Hwang, "Connected electric vehicles for flexible vehicle-to-grid (V2G) services", 2017 International Conference on Information Networking (ICOIN), 2017.
- [46] D. Liu, Y. Wang and Y. Shen, "Electric Vehicle Charging and Discharging Coordination on Distribution Network Using Multi-Objective Particle Swarm Optimization and Fuzzy Decision Making", *Energies*, vol. 9, no. 3, p. 186, 2016.

- [47] M. Alonso, H. Amaris, J. Germain and J. Galan, "Optimal Charging Scheduling of Electric Vehicles in Smart Grids by Heuristic Algorithms", *Energies*, vol. 7, no. 4, pp. 2449-2475, 2014.
- [48] F. Khosrojerdi, S. Taheri, H. Taheri and E. Pouresmaeil, "Integration of electric vehicles into a smart power grid: A technical review", 2016 IEEE Electrical Power and Energy Conference (EPEC), 2016.
- [49] I. Koutsopoulos and L. Tassiulas, "Challenges in demand load control for the smart grid", *IEEE Network*, vol. 25, no. 5, pp. 16-21, 2011.
- [50] M. Kesler, M. Kisacikoglu and L. Tolbert, "Vehicle-to-Grid Reactive Power Operation Using Plug-In Electric Vehicle Bidirectional Offboard Charger", *IEEE Transactions on Industrial Electronics*, vol. 61, no. 12, pp. 6778-6784, 2014.
- [51] K. Sayed and H. Gabbar, "Electric Vehicle to Power Grid Integration Using Three-Phase Three-Level AC/DC Converter and PI-Fuzzy Controller", *Energies*, vol. 9, no. 7, p. 532, 2016.
- [52] "Implement controlled current source - Simulink - MathWorks United Kingdom", *Se.mathworks.com*, 2017. [Online]. Available: <https://se.mathworks.com/help/physmod/sps/powersys/ref/controlledcurrentsource.html;jsessionid=73aae1e71ebd1a811ea472c50746>. [Accessed: 17- May- 2017].
- [53] "AC/DC Three-Level PWM Converter - MATLAB & Simulink Example - MathWorks United Kingdom", *Se.mathworks.com*, 2017. [Online]. Available: <https://se.mathworks.com/help/physmod/sps/examples/ac-dc-three-level-pwm-converter.html>. [Accessed: 22- May- 2017].
- [54] 2017. [Online]. Available: <http://www.nordkraftnett.no/getfile.php/133423/Nordkraft%20Nett%20dokumenter/Nettleie%202017%20oversikt%20web%20og%20avisa.pdf>. [Accessed: 30- May- 2017].

Appendix

A1 Regional load control

The quadratic optimization of regional load control implemented in this study to achieve minimum cost of charging electric vehicle (EV) batteries is presented in this appendix. The general form of quadratic programming is given as:

$$\text{minimize } \left(\frac{1}{2} x^T H x + f^T x \right) \quad (A1.1)$$

The objective function defined for regional load control in chapter 4.3 is given as:

$$\min \sum_{t=1}^T \sum_{i=1}^U (P_t + C_{i,t})^2 \quad (A1.2)$$

Here, P_t is utility power demand without charging/discharging power of EVs in time interval t , and $C_{i,t}$ is charging/discharging power of i^{th} EV in time interval t . From equation (A1.1) and equation (A1.2) it is clear that, to perform quadratic programming or quadratic optimization equation (A1.2) needs to be formulated in quadratic programming general form. The process of converting (A1.2) in to (A1.1) is elaborated below.

\mathbf{x} in (A1.1) is a vector containing all the states of all parameters involved in quadratic programming, that is, state of charge (SOC) of each area in a region (residential, industrial and commercial), charging/discharging current, charging/discharging power of EVs in each area and utility power. Vector \mathbf{x} in this study is defined as equation (A1.3).

$$x = \begin{bmatrix}
SOC_t^{residential} \\
SOC_t^{commercial} \\
SOC_t^{industrial} \\
\vdots \\
SOC_T^{residential} \\
SOC_T^{commercial} \\
SOC_T^{industrial} \\
I_t^{c,residential} \\
I_t^{c,commercial} \\
I_t^{c,industrial} \\
\vdots \\
I_T^{c,residential} \\
I_T^{c,commercial} \\
I_T^{c,industrial} \\
C_t^{residential} \\
\vdots \\
C_T^{residential} \\
C_t^{commercial} \\
\vdots \\
C_T^{commercial} \\
C_t^{industrial} \\
\vdots \\
C_T^{industrial} \\
P_t + C_t^{residential} + C_t^{commercial} + C_t^{industrial} \\
\vdots \\
P_T + C_T^{residential} + C_T^{commercial} + C_T^{industrial}
\end{bmatrix}_{240 \times 1} \tag{A1.3}$$

In equation (A1.3), each SOC represents collective SOC of all EVs available in a particular area in a particular time interval. For instance, $SOC_t^{residential}$, represents SOC of all EVs in residential area in time interval t. Similarly, charging/discharging current and charging discharging power follow the same manner as SOC parameter. Finally, last parameters give total utility power demand in each time interval t including charging/discharging power of EVs in all areas to minimize cost of charging, for both utilities and EV owners, $(P_t + C_t^{residential} + C_t^{commercial} + C_t^{industrial})$. In this study, T=24 to compute behavior over a period of 24 hours.

The next phase of quadratic programming form is designing \mathbf{H} and \mathbf{f} weight matrix and vector, respectively, to form equation objective function in equation (A1.2). the matrix \mathbf{H} and vector \mathbf{f} implemented in this study are given below.

$$H = \begin{bmatrix} \begin{bmatrix} 0 & \dots & 0 \\ \vdots & \ddots & \vdots \\ 0 & \dots & 0 \end{bmatrix} & \begin{bmatrix} 0 & \dots & 0 \\ \vdots & \ddots & \vdots \\ 0 & \dots & 0 \end{bmatrix} \\ \begin{bmatrix} 0 & \dots & 0 \\ \vdots & \ddots & \vdots \\ 0 & \dots & 0 \end{bmatrix} & \begin{bmatrix} 1_{217 \times 217} & 0 & \dots & 0 \\ 0 & & \ddots & \vdots \\ \vdots & & & 0 \\ 0 & \dots & 0 & 1_{240 \times 240} \end{bmatrix} \end{bmatrix}_{240 \times 240} ; \quad f = \begin{bmatrix} 0 \\ \vdots \\ 0 \end{bmatrix}_{240 \times 1} \quad (A1.4)$$

In (A1.4) \mathbf{H} matrix is split to form a better understanding. Otherwise, it is one square symmetric matrix containing diagonal elements as 1's for corresponding elements in \mathbf{x} vector to be squared. For example, in this study the elements involved in objective function of regional load control are the last 24 elements of state vector \mathbf{x} , that is, utility power with charging and discharging power of EVs. Therefore, \mathbf{H} in (A1.4) has all elements as zeros except ones in diagonal elements corresponding to last 24 elements of \mathbf{x} to form objective function.

In this study, there are no linear terms involved in objective function therefor, vector \mathbf{f} is all zeros vector.

Similar methodology is applied to area load control for individual area. The difference is observed in state vector where charging power of only EVs in each area is considered individually in different program instead of using them in one program like this one.