

# Modeling and Simulation of Heat Transfer in Blocks with Thin Pipes

**Renate Karlsen**

*Master's thesis in Computer Science, June 2017*

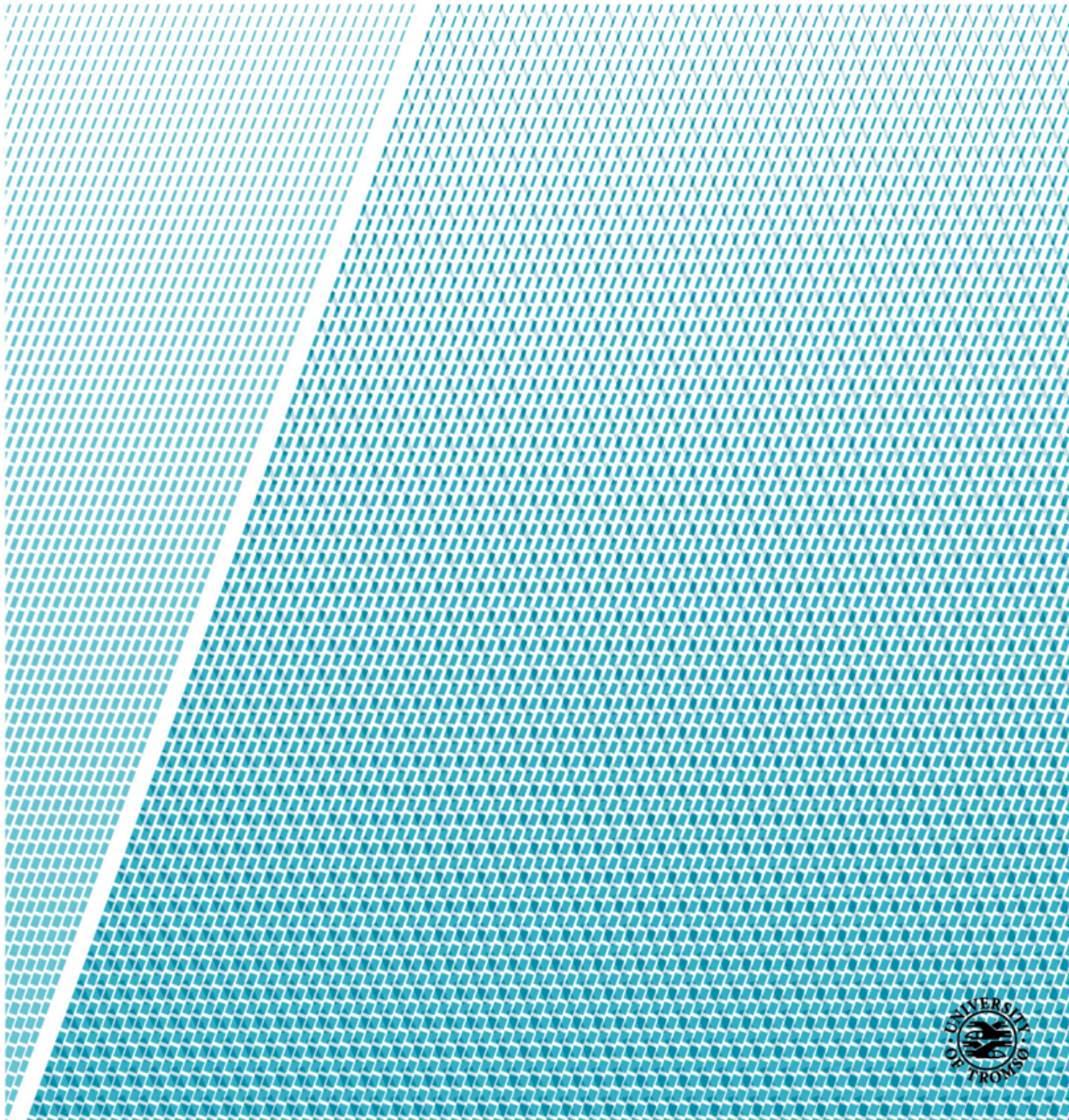



---

**UiT** / THE ARCTIC UNIVERSITY  
OF NORWAY

*Title: Modeling and Simulation of Heat Transfer  
in Blocks with Thin Pipes*

*Date: 06.06.2017*

*Classification: Open*

*Pages: 56*

*Author: Renate Karlsen*

*Faculty: Engineering Science and Technology*

*Department: Computer Science and Computational Engineering*

*Course code: SHO6264 Diploma Thesis - M-IT*

*Supervisors: Klas Pettersson and Hung Thanh Nguyen*

*Principal: UiT - The Arctic University of Norway (Campus Narvik)*

*Principal contact: Klas Pettersson*

*Keywords: asymmetric, symmetric, fluid velocity, temperature, numerical simulation, modified Stokes equations, natural convection-diffusion equations*

*Abstract (English):*

The report presents modified Stokes equations and natural convection-diffusion equations that are needed to implement a system which uses natural convection to transport energy from one area to another. The thesis also includes results from a numerical simulations that used these equations as arguments.

*Abstract (Norwegian):*

Rapporten presenterer modifiserte Stokes likninger og naturlig konveksjon-diffusjon likninger som trengs for å implementere et system som bruker naturlig konveksjon til å transportere energi fra et område til et annet område. Avhandlingen inkluderer også resultater fra numeriske simuleringer som brukte disse likningene som argumenter.

**Department of Computer Science and Computational Engineering**

**UiT - The Arctic University of Norway (Campus Narvik)**

## Acknowledgement

The author would like to thank her supervisors Klas Petterson and Hung Thanh Nguyen for providing the knowledge, effort, experience and for giving the author the opportunity to work on an interesting thesis. A special thanks to Klas Petterson for providing good advice and support during the Master thesis. In addition, the author would like to thank her family and friends for the motivation given throughout the Master's degree and Master thesis.

UiT - The Arctic University of Norway

Renate Karlsen  
6th June 2017, Narvik



# Contents

<b>Acknowledgement</b>	<b>i</b>
<b>1 Introduction</b>	<b>1</b>
1.1 Objectives . . . . .	1
1.2 Preliminaries . . . . .	1
1.2.1 Fluid motion . . . . .	1
1.2.2 Convection . . . . .	2
1.2.3 Diffusion . . . . .	3
1.3 Previous work . . . . .	4
1.3.1 Bachelor thesis . . . . .	4
1.3.2 Nuclear reactors and natural convection . . . . .	5
1.4 Report structure . . . . .	5
<b>2 Chosen methods</b>	<b>7</b>
2.1 Modified Stokes equations and natural convection-diffusion equations . . . . .	7
2.2 Numerical simulation . . . . .	10
2.3 3D model . . . . .	11
2.4 2D model . . . . .	13
<b>3 Results</b>	<b>14</b>
3.1 Calculations for how much time that is required to get enough energy needed to heat up the concrete . . . . .	14
3.2 Numerical simulation . . . . .	15
3.3 3D model . . . . .	15
3.4 2D model . . . . .	16
3.4.1 Symmetric flux . . . . .	18
3.4.2 Asymmetric flux . . . . .	23
3.4.3 10 degrees set symmetrically in the system . . . . .	27
3.4.4 Asymmetric degrees set in the system . . . . .	31
3.4.5 Diffusion . . . . .	39
<b>4 Discussion of the results</b>	<b>40</b>
4.1 The modified Stokes equations, the natural convection-diffusion equations and the required time to heat up the concrete . . . . .	40
4.2 Numerical simulation . . . . .	40
4.2.1 The 3D models and the 2D model . . . . .	40
<b>5 Concluding remarks</b>	<b>42</b>
5.1 Conclusion . . . . .	42
5.2 Recommendations for future work . . . . .	42
<b>References</b>	<b>44</b>
<b>Appendices</b>	<b>46</b>
<b>A Project description</b>	<b>46</b>
<b>B Plan of progress</b>	<b>53</b>



## List of Figures

1	Laminar flow profile. . . . .	2
2	Forced convection. . . . .	2
3	Natural convection. . . . .	3
4	Diffusion. . . . .	3
5	Setup for most of the laboratory experiments done during Trond Fagerjords Bachelor thesis. . . . .	4
6	Simplified design for the decay heat removal system in a nuclear reactor. . . . .	5
7	The most simple 3D model design layout. . . . .	11
8	A bit more advanced 3D model design layout. . . . .	12
9	The most advanced 3D model design layout. . . . .	12
10	The chosen design layout for the 2D model. . . . .	13
11	The flow inside one of the 3D models when the domain was set to be fluid. . . . .	15
12	Larger errors occurred when sub domains were implemented in one of the 3D models. . . . .	16
13	2D model with five measurement points for the fluid velocity and the temperature. . . . .	17
14	Directions of the symmetric and asymmetric flux used in the system. . . . .	17
15	The 2D model where 10 degrees were symmetrically set at the eastern side of the concrete. . . . .	18
16	The two asymmetrically cases for the 2D model, where constant temperature values were set. . . . .	18
17	The temperature and velocity in the system with symmetric flux. . . . .	19
18	The temperature and the fluid velocity is measured in 5 measurement points for the symmetric flux. . . . .	20
19	The temperature and the fluid velocity in the system with asymmetric flux. . . . .	23
20	The temperature and the fluid velocity is measured in 5 measurement points for the asymmetric flux. . . . .	24
21	The temperature and the fluid velocity in the system with 10 degrees symmetrically set at the eastern side of the concrete. . . . .	27
22	The temperature and fluid velocity is measured in 5 measurement points with 10 constant degrees symmetrically set at the eastern side of the concrete. . . . .	28
23	The temperature and the fluid velocity in the system with 10 degrees symmetrically set at one side. . . . .	31
24	The temperature and the fluid velocity is measured in 5 measurement points with 10 degrees asymmetrically set at the southern side of the concrete. . . . .	32
25	The temperature and the fluid velocity in the system with 10 and 40 degrees asymmetrically set at the eastern side of the concrete. . . . .	35
26	The temperature and the fluid velocity is measured in 5 measurement points with 40 and 10 degrees asymmetrically set at the eastern side of the concrete. . . . .	36
27	Diffusion in the 2D model. . . . .	39

## List of Tables

1	Symbols used in the modified Stokes equations which is dependent on a temperature gradient and the convection-diffusion equations. . . . .	7
2	Symbols with values for the concrete and the water. The values are used in the modified Stokes equations which is dependent on a temperature gradient and the convection-diffusion equations [1, 2, 3]. . . . .	8
3	Values used to calculate the energy needed to heat up the concrete. . . . .	14
4	Average temperature over the domain for 10 days in the symmetric flux system. . .	22
5	Average temperature over the domain for 10 days in the asymmetric flux system. . .	26
6	Average temperature over the domain for 10 days, where 10 degrees was set symmetrically in the system. . . . .	30
7	Average temperature over the domain for 10 days, where 10 degrees was set asymmetrically in the system. . . . .	34
8	Average temperature over the domain for 10 days, where 10 and 40 degrees were set asymmetrically in the system. . . . .	38



# 1 Introduction

Today most systems use forced convection to transfer heat, which require more maintenance, expenses and surveillance than natural convection systems [4]. Forced convection systems causes more turbulent flow than a natural convection system [4]. The thesis focuses on how to transport energy from one area to another with the use of natural convection. The topic is fairly new and it has not been investigated as much as forced convection. A connection between a modified Stokes equation and the natural convection-diffusion equation were used to create the desired solution in this thesis. The first subsection describes the objectives for the thesis. The second subsection presents the theory used in the thesis. The third subsection focuses on previous work done in this field and the final subsection presents the report structure.

## 1.1 Objectives

The goal of the thesis was to model and simulate energy transport in concrete with thin pipes carrying fluids. In this Master thesis, it was important to find out how you transport energy in concrete from one area to another with the use of natural convection. The initial study was to focus on the physical experiment done by Trond Fagerjord (Bachelor thesis) [2] as a basis for the numerical simulation. The numerical simulation needed to be validated/calibrated with the physical experiment. The physical experiment was carried out in the laboratory at Narvik University College in collaboration with Norut Narvik in 2013. A thin pipe filled with water was molded into a concrete block that was under the influence of external heating elements. Different temperature measurements were done during the project period. The purpose of the experiments were to study and develop a better understanding of possible applications to more efficient passive energy transfer technology. The Bachelor thesis by Trond Fagerjord is discussed in more detail in section 1.3.1. The identification of important design parameters was a second objective. Specific goals for the thesis were:

- A model of energy transport.
- A numerical simulation of the energy transport.
- An analysis of the agreement between the experimental data and the numerically obtained data.
- An analysis of which design parameters that are deciding for the heat driven flow within the system.

## 1.2 Preliminaries

This section presents the theory used in the thesis. The first subsection gives an introduction to the fluid motion applied in the thesis. The next subsection describes the difference between forced convection and natural convection. The last subsection presents diffusion.

### 1.2.1 Fluid motion

The fluid that was applied in the thesis was water. The motion of the fluid was determined by the temperature and the pressure. The temperature could be defined by a particular degree or the heat flux. The flux is the rate of heat energy transport through a surface. Specific water values are listed in table 2. In the physical experiment done by Trond Fagerjord (section 1.3.1), the heating

of the concrete took a very long time. Which in turn gave a remarkably slow fluid velocity, since the fluid velocity was dependent on the temperature and the pressure, i.e. natural convection. This may indicate that the flow profile was laminar. The Reynolds number ( $Re$ ) is an expression that helps to predict the flow type:

$$Re = \frac{\rho \cdot u \cdot L}{\mu} \quad (1)$$

where  $\rho$  is the fluid density ( $kg/m^3$ ),  $u$  is the fluid velocity ( $m/s$ ),  $L$  is the dimension ( $m$ ) and  $\mu$  is the dynamic viscosity of the fluid ( $Pa \cdot s = kg/s \cdot m$ ). For laminar flow the  $Re < 2000$  [5]. It is more natural that turbulent flow profiles occurs in systems that uses forced convection. Based upon the the physical experiment and the objectives, laminar flow was used in the thesis as the flow profile, since the thesis focuses on natural convection (figure 1).

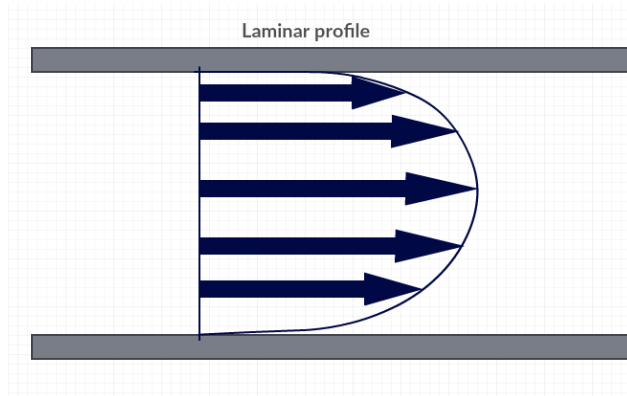

Figure 1: Laminar flow profile.

### 1.2.2 Convection

There are many approaches to transfer heat and fluid motion. One of the most common and popular methods is to use forced convection, which is generated by an external source like a fan, pump, suction device and so on (for instance figure 2).

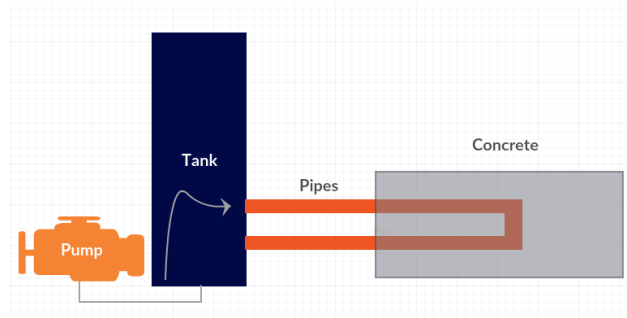

Figure 2: Forced convection.

In figure 2 the system is generated by a pump. The tank is filled with a fluid and the pump generates circulation in the tank, which again gives the fluid a velocity. The fluid then moves through the pipes which is connected to the concrete block. At the end the fluid circulates back to the tank, and the process continues. The pump generate the fluid motion until the pump is switched off.

In natural convection the fluid motion is not generated by any external sources (figure 3)

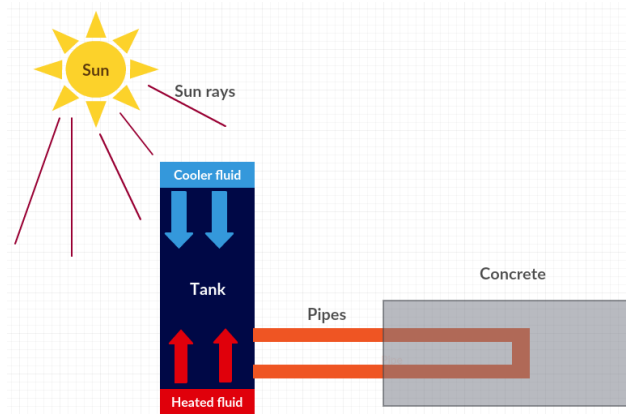

Figure 3: Natural convection.

The fluid motion is caused by the difference in density occurring due to temperature gradients, i.e. the fluid becomes less dense when it receives heat which makes the fluid rise. The difference in fluid density results in the buoyancy effect. The fall in the surrounding cooler fluid then moves to replace it. The cooler fluid is then heated and the process continues. The heat at the bottom is then transferred to the top [6].

### 1.2.3 Diffusion

Diffusion is a physical process where particles move from a high concentration region to a low concentration region. This occurs when particles scatter around in liquids or gases. Diffusion can only happen in a solution of liquids or gases (figure 4):

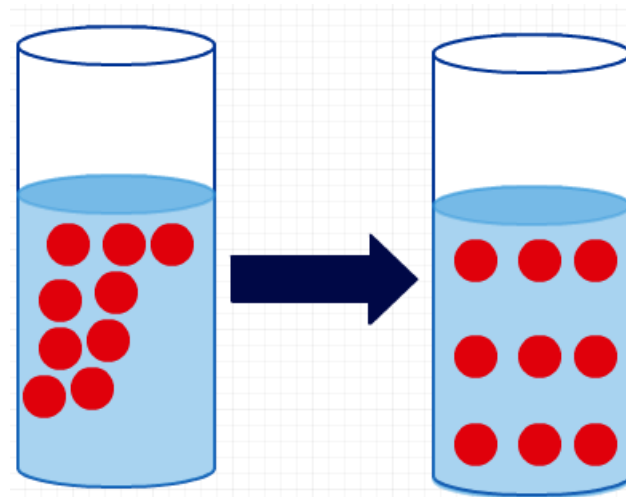

Figure 4: Diffusion.

Figure 4 displays how diffusion works. The first container illustrates particles in a liquid. The second container illustrates a few seconds later when the particles have scattered around in the same liquid. The diffusion velocity depends on the pressure and the temperature gradients present in the concentration of the gases or the liquids.

### 1.3 Previous work

This section presents a brief explanation of the Bachelor thesis done by Trond Fagerjord and which impact natural convection has on nuclear reactors. For more detailed description about the Bachelor thesis and natural convection in nuclear reactors, please consult references [2, 7, 4]

#### 1.3.1 Bachelor thesis

A bachelor thesis done by Trond Fagerjord concerns exploitation of solar energy in concrete. The main purpose was to examine the exploitation of excess energy in concrete due to solar energy. The thesis included several laboratory experiments done at Narvik University College, where the experiments were observed over several days. In the beginning of the laboratory experiments, a pump was used to create circulation in the water loop, i.e. forced convection. The rest of the lab experiments were done without any pump, i.e. natural convection (figure 5). Even after the first experiment without any pump, successful results were achieved.

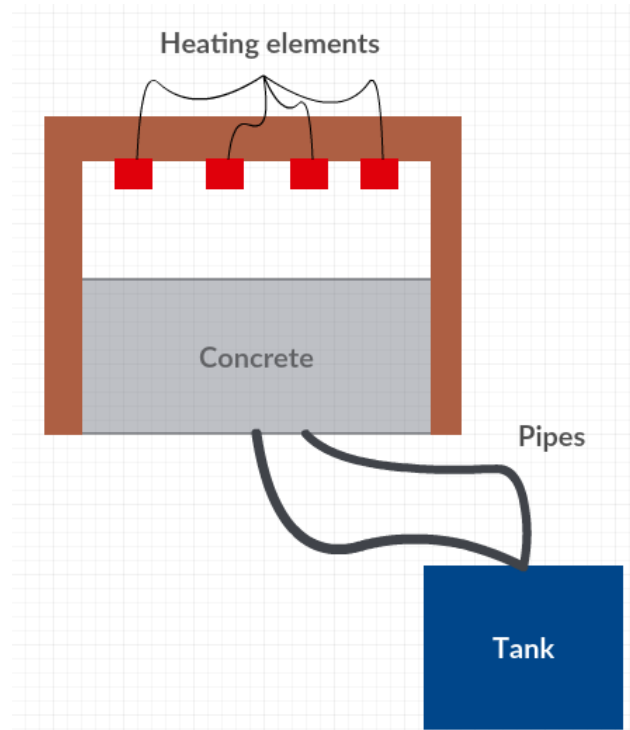

Figure 5: Setup for most of the laboratory experiments done during Trond Fagerjords Bachelor thesis.

As seen in figure 5, four heating elements with 1000 W were used. Two pipes were attached to the tank (containing water) and were molded into the concrete. After 17 hours the water had a temperature of 20°C. Eventually the temperature became stable and the heating elements were turned off. The temperature continued to decrease as there were no heat source to keep the flow motion going. Fagerjord discovered that the natural convection experiments made a small fluid velocity. He concluded that the system needed to be connected to a heating system for the flow motion to keep moving. The temperature gradient would be constant and the fluid motion would never stop, because the temperature gradient would not at any time be too reduced (reference [2] has been used for this whole section).

### 1.3.2 Nuclear reactors and natural convection

Natural convection are implemented in nuclear power plants for more secure safety procedures and for the removal of decay heat. In addition, natural convection are also used in the storage facilities in nuclear power plants, where the cooling of radioactive waste plays an important role. Nuclear reactors generates heat even after shutdown because of the decay of radioactive fission. Previous nuclear power plants accidents demonstrates that the heat has to be removed to maintain the temperatures within safe limits. This is one reason why almost all nuclear reactors are designed to remove heat decay by natural convection. Humboldt Bay, Dodewaard and VK-50 are some nuclear reactors that use natural convection as the core cooling system [7].

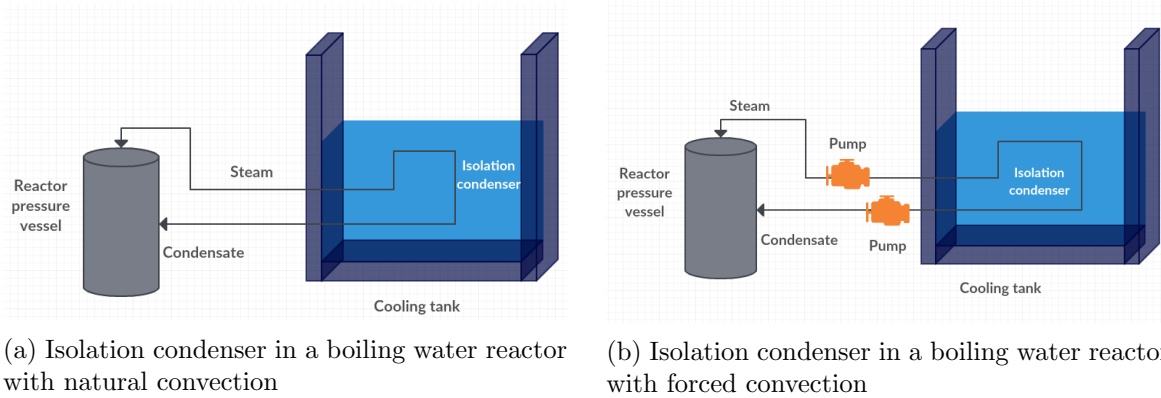

Figure 6: Simplified design for the decay heat removal system in a nuclear reactor.

Figure 6 illustrates a design for a decay heat removal system that is based on both natural and forced convection. The heat sink capacity determines how long the mission time is. Most system has mission time from 30 minutes to 72 hours. However, in some cases the mission time can be unlimited [7].

A technical document done by the International Atomic Energy Agency (IAEA) concerns natural convection for advanced water cooled reactors. The main purpose was to examine the safety of future water cooled nuclear power plants and improve the economic goals. A common view between the experts in this research field and nuclear power plant design organizations, noted that the first consideration was to satisfy the required safety function with adequate reliability. It was also important to study the affect on nuclear power plant operations, where design simplicity and the expenses for the nuclear power plants needed to be taken into consideration. It is also mentioned that an asymmetric model that is based on natural convection is more effective than a symmetric model [4].

## 1.4 Report structure

There are 5 main sections in this report, with the purpose of explaining and presenting the Master thesis. Some of the main sections has several subsections that presents different topics that is relevant to the main section. The sections are as follows:

### 1 Introduction

Section 1 gives an introduction to the thesis. The first subsection describes the objectives and the goals of the thesis. The next subsection presents the preliminaries with some general and applied theory in the thesis. The final subsection is about previous work within the relevant field.

## **2 Chosen methods**

Section 2 describes the chosen methods applied in the thesis. The first subsection presents the modified Stokes equations and the natural convection-diffusion equations. The next subsection is about the numerical simulation. The final subsections presents the chosen 3D and 2D design layouts for the models applied in the numerical simulation.

## **3 Results**

Section 3 presents the results achieved in the thesis. The first subsection describes the calculations for how much time that is required to get enough energy needed to heat up the concrete. The next subsection presents some details about the computer that was used during the numerical simulations. The third subsection displays the results from the 3D model. The final subsection presents the 2D model with several symmetric and asymmetric systems with different temperature gradients. In addition, the final subsection presents the results from the diffusion test in the numerical simulation.

## **4 Discussion of the results**

Section 4 presents the discussion of the results that was achieved in section 3. In addition, section 4 presents explanations for why the different results occurred.

## **5 Concluding remarks**

Section 5 ends the thesis with some concluding remarks and recommendations for future work in this field.

## 2 Chosen methods

This section presents the chosen methods used in the Master thesis. The first section presents the equations used for the flow and the heat transport. The next section is about the numerical simulation, which explains the programming language, programming library and tools implemented in the numerical simulation. The third section describes the chosen 3D models design layouts that were implemented in the numerical simulation. The last section concerns the chosen 2D model design layout that was applied in the numerical simulation.

### 2.1 Modified Stokes equations and natural convection-diffusion equations

The laminar flow profile (figure 1) was chosen as the fluid velocity flow profile for the thesis. As a result of this decision, a part of the Navier-Stokes equations were chosen as a reasonable solution for the flow profile. A modified Stokes equation which was dependent on a temperature gradient was used for the fluid velocity. In addition, the convection-diffusion equation were chosen as a solution to the transport of heat. The heat was chosen to have no external sources, it was either driven by the flux or by a given temperature in degrees. The physical experiment used millimeters for measuring the dimensions, while the equations in this section focuses on meters for measuring dimensions [2]. The numerical simulation chose diameters for the dimensions. That is why  $\nabla$  is converted to value 10 and  $\nabla^2$  is converted to value 100. The system is dependent on time, we want to measure several results on different time intervals. Table 1 and table 2 illustrates the symbols used in the modified Stokes equations which is dependent on a temperature gradient and the convection-diffusion equations. Table 1 displays only what the meaning of each symbols is, while table 2 shows a more detailed description about the symbols.

Constant	Description	Units
$\nabla$	Set to 10 to get the correct dimensions	-
$\nabla^2$	Set to 100 to get the correct dimensions	-
$\beta$	Adjustable constant	-
$F$	Forces	-
$g$	Flux	$(quantity/(time \cdot area))$
$p$	Pressure	$Pa = (kg/(m/s^2))$
$t$	Time	Hours or seconds
$u$	Velocity	$m/s$
$v$	Test function	-
$w$	Test function	-
$q$	Test function	-

Table 1: Symbols used in the modified Stokes equations which is dependent on a temperature gradient and the convection-diffusion equations.

Constant	Description	Units	Value concrete	Value water
$\alpha$	Thermal diffusivity	$m^2/s$	$2.80164 \cdot 10^{-7} m^2/s$	$4.06116 \cdot 10^{-7} m^2/s$
$c_p$	Specific heat capacity	$(J/(kg \cdot K))$	880 $(J/(kg \cdot K))$	4186 $(J/(kg \cdot K))$
$k$	Thermal conductivity	$(W/(m \cdot K))$	1.73 $(W/(m \cdot K))$	0.58 $(W/(m \cdot K))$
$\rho$	Density	$kg/m^3$	2460 $kg/m^3$	1000 $kg/m^3$
$T$	Temperature	$^{\circ}C$	Changing over time	Changing over time
$\mu$	Dynamic viscosity	$Pa \cdot s = (kg/(s \cdot m))$	-	1.5673 $(kg/(s \cdot m))$

Table 2: Symbols with values for the concrete and the water. The values are used in the modified Stokes equations which is dependent on a temperature gradient and the convection-diffusion equations [1, 2, 3].

The modified Stokes equations which is dependent on a temperature gradient was set as follows:

$$\rho \frac{\partial u}{\partial t} - \mu \nabla^2 u + \nabla p = \beta \nabla T \quad \text{in } \Omega \times [0, T] \quad (2)$$

$$\text{div } u = 0 \quad \text{in } \Omega \times [0, T] \quad (3)$$

$$u = 0 \quad \text{on } \delta\Omega \times [0, T] \quad (4)$$

$$u(0) = u_0 \quad \text{at } \Omega \times \{0\} \quad (5)$$

Where  $\beta$  is a adjustable term in equation (2). One approach to solve time dependent partial differential equations (PDEs) is by using the finite element method (FEM). First discrete the time derivate by a finite difference approximation, which yields a sequence of stationary problems, and then turn each stationary problem into a variational formulation [8]. This is done by using:

$$\rho \frac{u^{n+1} - u^n}{\Delta t} - \mu \nabla^2 u^{n+1} + \nabla p^{n+1} = \beta \nabla T^{n+1} \quad (6)$$

Where  $\Delta t$  is the time discretization parameter. By continuing with equation (6), it follows that:

$$\rho u^{n+1} - \Delta t \mu \nabla^2 u^{n+1} + \Delta t \nabla p^{n+1} = \Delta t \beta (\nabla T^{n+1}) + u^n \quad (7)$$

Multiplying equation (7) with a test function  $v$  gives:

$$\rho u^{n+1} v - \Delta t \mu \nabla^2 u^{n+1} v + \Delta t \nabla p^{n+1} v = \Delta t \beta (\nabla T^{n+1} v) + u^n v \quad (8)$$

where  $v = 0$  on  $\delta\Omega$ , because the domain has the no-slip condition (there is no inflow, the domain is closed). The no-slip condition is a condition where the fluids velocity is zero at the boundaries. Integrating equation (8) gives:

$$\begin{aligned} & \rho \int_{\Omega} u^{n+1} v \, dx - \mu \Delta t \int_{\Omega} \nabla u^{n+1} \cdot \nabla v \, dx + \Delta t \int_{\Omega} \overbrace{p^{n+1} \text{div } v \, dx}^{\text{using the divergence theorem}} \\ & = \beta \Delta t \int_{\Omega} \nabla T^{n+1} \cdot v \, dx + \int_{\Omega} u^n v \, dx \end{aligned}$$

Collecting all the terms on one side of the equality sign gives:

$$\begin{aligned} & \rho \int_{\Omega} u^{n+1} v \, dx - \mu \Delta t \int_{\Omega} \nabla u^{n+1} \cdot \nabla v \, dx + \Delta t \int_{\Omega} p^{n+1} \text{div } v \, dx \\ & - \beta \Delta t \int_{\Omega} \nabla T^{n+1} \cdot v \, dx - \int_{\Omega} u^n v \, dx = 0 \end{aligned}$$



For the convection-diffusion calculations, equations (9) and (10) were used:

$$\frac{\partial T}{\partial t} - \nabla \cdot (\alpha \nabla T) + u \cdot \nabla T = F \quad (9)$$

where  $\alpha = \frac{k}{\rho \cdot c_p}$  from equation (9). In the numerical simulation  $F$  is set to zero. If  $F$  had been included in the numerical simulation, the simulation would display a system that is dependent on forced convection. Since the system is dependent on a temperature gradient (i.e. natural convection),  $F$  is set to zero in the numerical simulation. However  $F$  is applied in the calculations below to gain a more general solution. For a natural convection system,  $F$  is ignored (as it has been done in the numerical simulation).

$$T = \Gamma_1, \Gamma_2 \text{ and } \Gamma_3 \quad \text{on } \delta\Omega \times (0, T] \quad (10)$$

where  $\Gamma_1, \Gamma_2$  and  $\Gamma_3$  is:

$$\begin{aligned} \Gamma_1 &= 0 \quad \text{on } \delta\Omega \times (0, T] \\ \Gamma_2 &= g \quad \text{on } \delta\Omega \times (0, T] \\ \Gamma_3 &= 0 \quad \text{on } \delta\Omega \times (0, T] \end{aligned}$$

$$T = T_0 \quad \text{at } \Omega \times \{0\} \quad (11)$$

The meaning of each part in equation (9) is displayed in the equation below:

$$\begin{array}{c} \text{rate of change in temperature} \\ \underbrace{\frac{\partial T}{\partial t}} \\ \text{diffusion} \\ - \nabla \cdot (\alpha \nabla T) \\ \text{convection} \\ + u \cdot \nabla T \\ \text{Forces. F is set to zero} \\ = \underbrace{F} \end{array}$$

Using a finite difference discretization in temperature, we now have:

$$\frac{\partial T^{n+1}}{\partial t} - \nabla \cdot (\alpha \nabla T^{n+1}) + u^{n+1} \cdot \nabla T^{n+1} = F^{n+1} \quad (12)$$

$$\frac{T^{n+1} - T^n}{\Delta t} - \nabla \cdot (\alpha \nabla T^{n+1}) + u^{n+1} \cdot \nabla T^{n+1} = F^{n+1}$$

Multiplying the equation above by  $\Delta t$  gives:

$$T^{n+1} + \Delta t \nabla \cdot (\alpha \nabla T^{n+1}) - \Delta t (u^{n+1} \cdot \nabla T^{n+1}) = \Delta t F^{n+1} + T^n \quad (13)$$

Multiplying equation (13) with a test function  $w$  gives:

$$T^{n+1} w + \Delta t \nabla \cdot (\alpha \nabla T^{n+1}) w - \Delta t (u^{n+1} \cdot \nabla T^{n+1}) w = \Delta t F^{n+1} w + T^n w \quad (14)$$

Which gives the integrals:

$$\int_{\Omega} T^{n+1} w \, dx + \Delta t \int_{\Omega} \nabla \cdot (\alpha \nabla T^{n+1}) w \, dx - \Delta t \int_{\Omega} (u^{n+1} \cdot \nabla T^{n+1}) w \, dx = \Delta t \int_{\Omega} F^{n+1} w \, dx + \int_{\Omega} T^n w \, dx$$

Where

$$\Delta t \int_{\Omega} \nabla \cdot (\alpha \nabla T^{n+1}) w \, dx = -\Delta t \int_{\Omega} (\alpha \nabla T^{n+1} \cdot \nabla w) \, dx + \Delta t \int_{\partial\Omega} \overbrace{(\alpha \nabla T^{n+1} \cdot n) w}^{\Gamma_1, \Gamma_2, \Gamma_3} \, d\sigma$$

Collecting all terms on one side of the equality sign gives:

$$\begin{aligned} & \int_{\Omega} T^{n+1} w \, dx + \Delta t \int_{\Omega} (\alpha \nabla T^{n+1} \cdot \nabla w) \, dx - \Delta t \int_{\Omega} (u^{n+1} \cdot \nabla T^{n+1}) w \, dx \\ & - \Delta t \int_{\Omega} F^{n+1} w \, dx - \int_{\Omega} T^n w \, dx - \int_{\Gamma_2} g w \, d\sigma = 0 \end{aligned}$$

The next equation adds together the modified Stokes equations and the convection-diffusion equations. Equation (3) is multiplied with a test function  $q$ . Collecting all the equations gives a final equation that is used in the numerical simulation:

$$\begin{aligned} & \rho \int_{\Omega} u^{n+1} v \, dx - \mu \Delta t \int_{\Omega} \nabla u^{n+1} \cdot \nabla v \, dx + \Delta t \int_{\Omega} p^{n+1} \operatorname{div} v \, dx - \beta \Delta t \int_{\Omega} \nabla T^{n+1} \cdot v \, dx - \int_{\Omega} u^n v \, dx \\ & + \int_{\Omega} T^{n+1} w \, dx + \Delta t \int_{\Omega} \nabla \cdot (\alpha \nabla T^{n+1}) w \, dx - \Delta t \int_{\Omega} (u^{n+1} \cdot \nabla T^{n+1}) w \, dx - \Delta t \int_{\Omega} F^{n+1} w \, dx - \int_{\Omega} T^n w \, dx \\ & - \int_{\Gamma_2} g w \, d\sigma + \int_{\Omega} (\operatorname{div} u) \cdot q \, dx = 0 \end{aligned} \tag{15}$$

The two conditions  $\operatorname{div} u$  and  $u_0$  is the space discretization used by the FEMs. Since the thermal diffusivity ( $\alpha$ ) is different in water and in concrete, we want to achieve energy balance at the border of the water and the concrete. This can be applied by using equation (16):

$$k_{water} \nabla T_{water} \cdot n_{water} = k_{concrete} \nabla T_{concrete} \cdot n_{concrete} \tag{16}$$

It is also possible to just use the unit normal, which is done in equation (17):

$$k_{water} \nabla T_{water} \cdot n_{water} + k_{concrete} \nabla T_{concrete} \cdot n_{concrete} = 0 \tag{17}$$

This is done by using two test functions, where one is in the concrete and the other one is in the water for convection-diffusion.

## 2.2 Numerical simulation

The numerical simulation was created by using the programming language Python (version 2.7.12). In addition, the library FEniCS (version 2016.2.0) with DOLFIN as the core component was used. FEniCS is a library for computing partial differential equations. The library is open source and it comes with a lot of tutorials and documentation to solve simple and complex partial differential equations [9]. DOLFIN is the C++/Python interface of FEniCS, where it provides a consistent problem solving environment for ordinary and partial differential equations [10]. In order to use Python and FEniCS, a virtual machine (Oracle VM VirtualBox) was installed with Ubuntu (64 bit) as the operating system. Oracle VM VirtualBox can be installed on Windows, Linux, Macintosh, Solaris hosts and other operating systems [11]. Several 3D models and a 2D model with similarities to the physical experiment were chosen as the basis for the design layouts. However, the 3D models was the primary focus during the thesis, as the author decided early on that the chosen design layouts should be as similar as possible like the physical experiment. In addition, drawing of different graphs were also chosen as a method to compare the numerical simulation solution to the solution in the physical experiment. In the numerical simulation, the energy balance between water and concrete is assumed for simplicity to be like equation (18):

$$\frac{k_{water}}{\operatorname{approx} k_{concrete}} \tag{18}$$

In the numerical simulation, mixed methods were chosen as an approximation space. Mixed methods is used in a miscellaneous finite element methods, which have more than one approximation space. Usually one or more spaces applies the Lagrange method which implements limitations. However, for the Stokes equations the Galerkin approximation is used for the mixed method. One property of mixed methods is that not all the finite element spaces will lead to convergent approximations [12].

### 2.3 3D model

The 3D model was chosen as the primary focus during the thesis, where several design layouts were created. In the beginning, the idea was to study only the flow direction and add several boundary conditions in the X, Y and Z direction. This means that the domain only consisted of fluid, until more specifications were set (section 3). The boundary conditions were chosen to be around every block/shape with the no-slip condition as argument. However, some boundary conditions were even more precisely adjusted. For instance, when some of the blocks intersected with each other, a part of the boundary were removed. This was done due to the flow. If every block had boundary conditions, there would be no flow going through the other blocks. The most simple design layout for one of the 3D models is illustrated in figure 7:

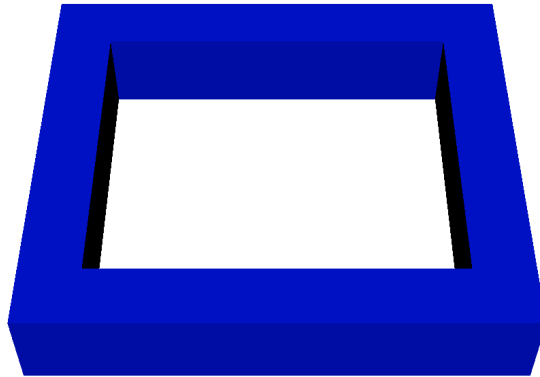
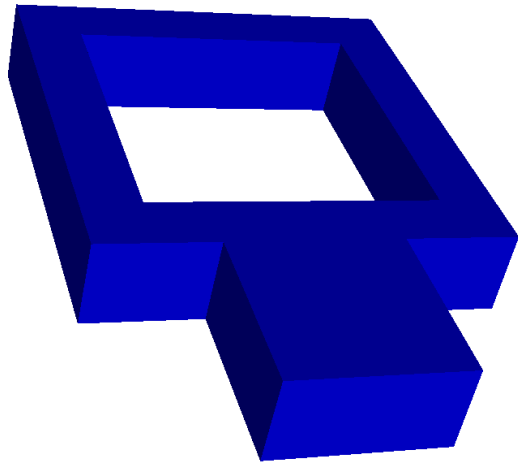
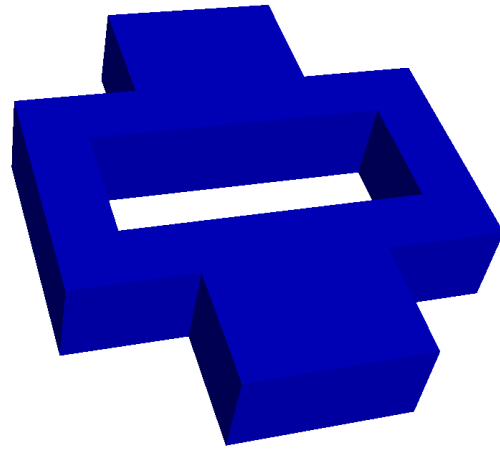

Figure 7: The most simple 3D model design layout.

The model consists of only 4 simple shapes, that indicate 4 pipes. The next chosen method was to create a bit more advanced 3D model design layout (figure 8), where the new shapes indicated concrete and the water tank.



(a) 3D model design layout with 4 pipes and 1 block (the water tank).



(b) 3D model design layout with 4 pipes and 2 blocks (the concrete and the water tank).

Figure 8: A bit more advanced 3D model design layout.

In figure 8 the models consists of pipes, the concrete and the water tank. As mentioned earlier in this section, the models did not have any specifications set, which means that nothing were set to be water, concrete or pipes. The figures in this subsection only displays the chosen 3D models for the different design layouts.

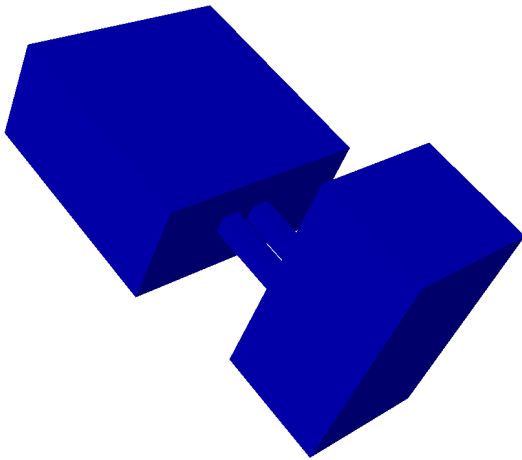

(a) 3D model design layout with 3 pipes and 2 blocks (the concrete and the water tank).

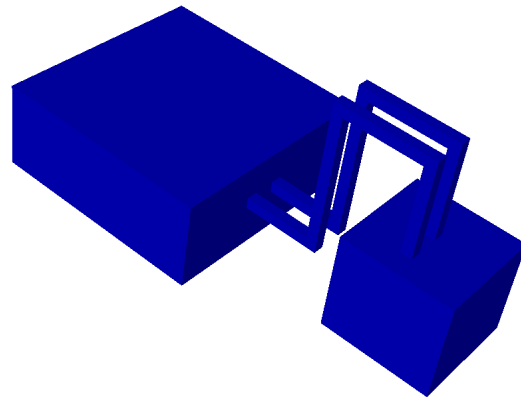

(b) 3D model design layout with several pipes and 2 blocks (the concrete and the water tank).

Figure 9: The most advanced 3D model design layout.

In figure 9a, the 3D model design layout consists of only 3 pipes and 2 blocks. The last pipe is not visible on the 3D model design layout because the pipe was inside the large block (the concrete). The highest block illustrates the water tank. Figure 9b consists of several thinner pipes and 2 blocks, where the largest block illustrates the concrete and the other block illustrates the water

tank. Also in this figure, not all the pipes are visible since they were inside the concrete block. The design layout in figure 9b, was the chosen layout with most similarities with the physical experiment according to appearance.

## 2.4 2D model

The 2D model was chosen as the secondary focus during the thesis, where one specific design layout was chosen. The physical experiment was a closed system with no inflow. Consequently, the boundary conditions were chosen to be around the whole domain with the no-slip condition as an argument. The 2D model was chosen to have some similar appearance as the system in the physical experiment [2].

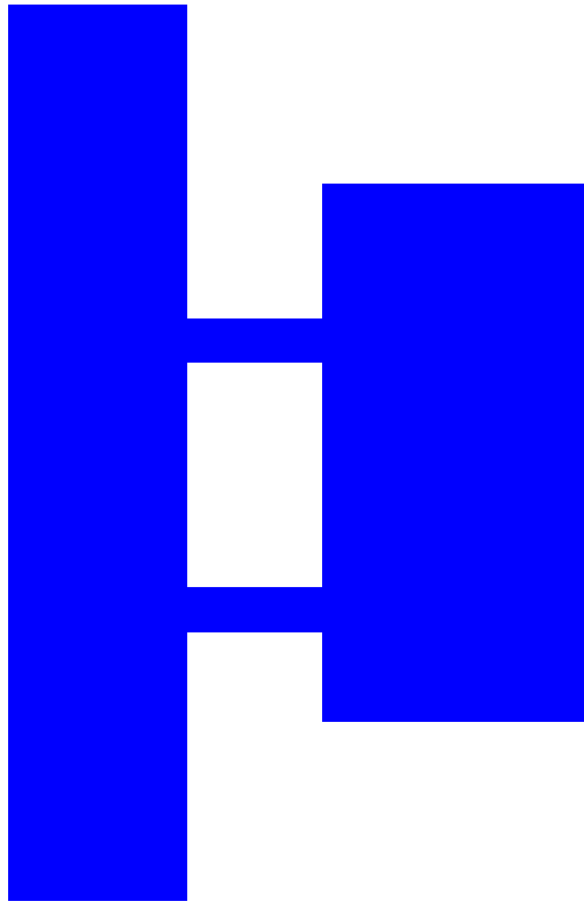

Figure 10: The chosen design layout for the 2D model.

The highest rectangular shape illustrates the water tank. The rectangular shape with the most width displays the concrete. The small rectangular shapes indicates the pipes in the system. Several symmetric and asymmetric temperature gradients were chosen to be further investigated in the 2D model. The reason why several symmetric and asymmetric systems were chosen to be especially investigated, were to gain information if any improvements occurred in the system. The chosen improvements to consider were the heat transport and the fluid velocity.

### 3 Results

This section presents the results of the numerical simulation done in Oracle VM Virtualbox. The first subsection presents calculations for how much time that is required to get enough energy needed to heat up the concrete, where the values calculated are compared with the output from the numerical simulations. The second subsection gives specifications on the computer used in the numerical simulation. The final two subsections describes the 3D model and the 2D model, where the 2D model has several symmetric and asymmetric systems.

#### 3.1 Calculations for how much time that is required to get enough energy needed to heat up the concrete

In order to calculate the energy needed to heat up the concrete, the density, the specific heat capacity and the volume of the concrete were required. The density and the specific heat capacity is already listed in table 2. The volume of the concrete is calculated as follows:

$$V = 0.6 \text{ m} \cdot 1.2 \text{ m} \cdot 1 \text{ m} = 0.72 \text{ m}^3 \quad (19)$$

where the numbers for the volume is collected from the numerical simulation model.

Constant	Description	Value
$\rho$	Density for concrete	2460 $kg/m^3$
$c_p$	Specific heat capacity	0.88 $kJ/(kgK)$
V	Concrete volume	0.72 $m^3$

Table 3: Values used to calculate the energy needed to heat up the concrete.

The energy per degree in the concrete can be calculated by using the obtained values from table 3 as follows:

$$\text{Energy per degree (E)} = c_p \cdot \rho \cdot V = 0.88 \text{ kJ}/(kgK) \cdot 2460 \text{ kg}/m^3 \cdot 0.72 \text{ m}^3 = 1558.66 \text{ kJ}/K \quad (20)$$

This means that if we heat the concrete from 0 to T, it corresponds to an average  $\Delta T$  and the specific heat capacity, the density and the volume for the concrete are required. For example 10 degrees on average requires equation (20) to be multiplied by 10, which gives 15586.6  $kJ/K$ . The four heating elements in reference [2], have each an effect of 1000 W (4000W in total). Then we can ask ourself if the total flux is 4000W, how long time is required to reach 15586.6  $kJ/K$  if the given temperature is 10 degrees? This is solved in equation (21):

$$\frac{15586.6 \text{ kJ}/K}{4 \text{ heating elements}} = 3896.64 \text{ seconds} = 64.944 \text{ minutes} = 1.0824 \text{ hours} \quad (21)$$

In the numerical simulation, both 10 and 40 degrees was chosen to be the constant temperatures (section 3.4). For 40 degrees the energy per degree is 62346.4  $kJ/K$ . If the total flux is 4000W, how long time is required to reach 62346.4  $kJ/K$  if the given temperature is 40 degrees? This is solved in equation (22):

$$\frac{62346.4 \text{ kJ}/K}{4 \text{ heating elements}} = 15586.6 \text{ seconds} = 259.776 \text{ minutes} = 4.3296 \text{ hours} \quad (22)$$

### 3.2 Numerical simulation

All tests were performed on a MSI GT73VR 6RE Titan computer with the following specifications:

- →**CPU:** Intel(R) Core(TM) i7-6820HK CPU @ 2.70GHz
- →**Memory:** DDR4-2400 16 GB
- →**Graphic card:** Nvidia GeForce GTX 1070
- →**OS:** Windows 10 Home

All tests were programmed with Python in Oracle VM VirtualBox. There are some errors in the numerical simulation. However, the data obtained from the numerical simulation can be analyzed more generally. The results in section 3.4 have some errors according to temperature and fluid velocity, but the result are regardless displayed.

### 3.3 3D model

The 3D models design layouts were created by using embedded shapes from FEniCS. A working solution for all the 3D models were when the domain was set to be fluid. The flow had a reasonable direction as seen in figure 11.

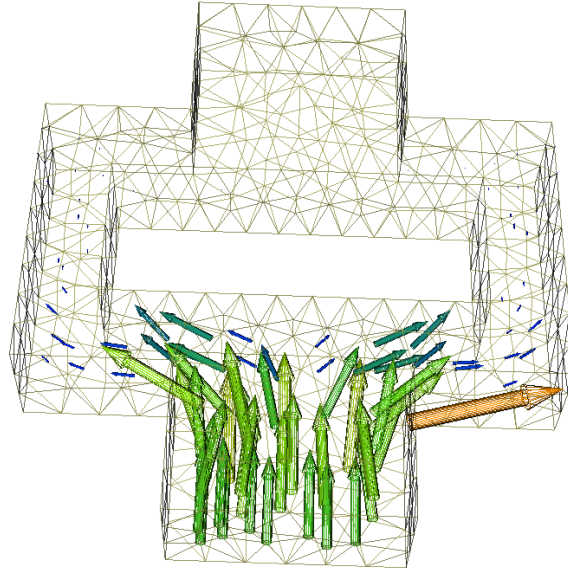

Figure 11: The flow inside one of the 3D models when the domain was set to be fluid.

In figure 11, the domain was set to be fluid. The flow starts from a positive Z direction and goes along the Z axis in the negative direction. The boundary conditions were set and the flow did not go outside the boundaries. The large orange arrow on the figure can be considered as an deviation. Similar results were displayed in the other 3D models, where the flow went in the correct direction and not outside the boundary conditions. When the domain needed to be specified as fluid and concrete (by defining sub domains), larger problems occurred, as seen in figure 12.

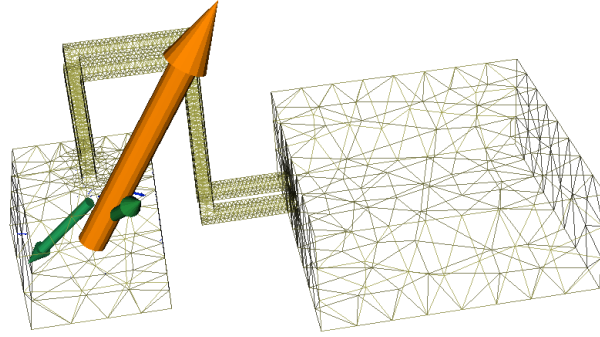

Figure 12: Larger errors occurred when sub domains were implemented in one of the 3D models.

By defining sub domains in 3D models, significantly high errors occurred (as figure 12 illustrates). Problems arose when the sub domains were defined as either water or concrete. During the thesis, the author tried to contact the developers of FEniCS about sub domains for 3D models per email, but unfortunately they did not respond. After much time and research, FEniCS do not support sub domains in 3D. As it turns out, the FEniCS library is currently under development for all necessary 3D model support that was essential for this thesis [13, 14, 15].

### 3.4 2D model

The 2D model design layout were created by using embedded shapes from FEniCS. No errors occurred when the 2D model was implemented with boundary conditions and sub domains. The first sub domain displays the fluid and the second sub domain illustrates the concrete. Figure 13 displays the 2D model with 5 measurement points used in the numerical simulation.



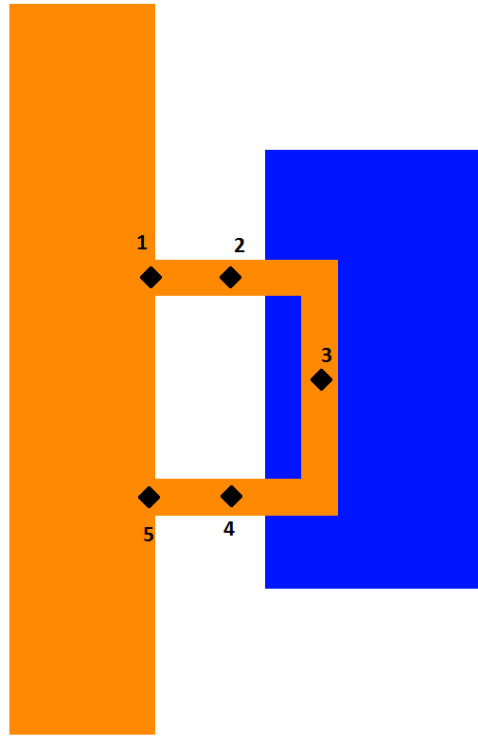

Figure 13: 2D model with five measurement points for the fluid velocity and the temperature.

Figure 13 has 5 points (black marks). These points are measurement points for the fluid velocity (in the X and Y direction) and the the temperature in each point. The orange area in the figure are the first sub domain (fluid) and the blue area are the second sub domain (concrete). The 5 measurement points gives data from several symmetric and asymmetric systems, which is driven by the flux and different temperature values that is set in the numerical simulation.

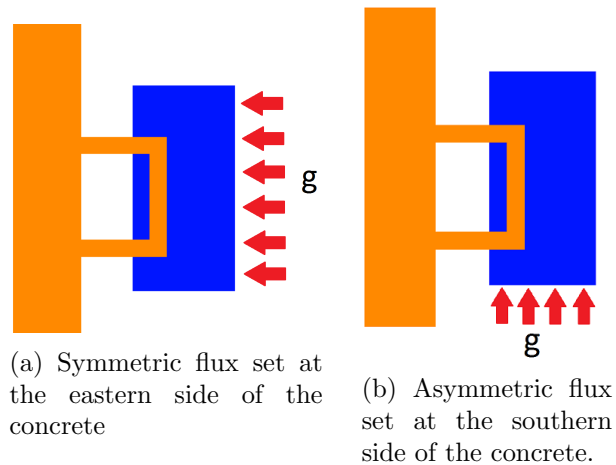

Figure 14: Directions of the symmetric and asymmetric flux used in the system.

Figure 14 displays the 2D model driven by a symmetric and an asymmetric flux. In addition, constant temperatures were set symmetrically and asymmetrically in the system. The symmetrically system had just one case, where 10 degrees were set at the eastern side of the concrete (figure 15).

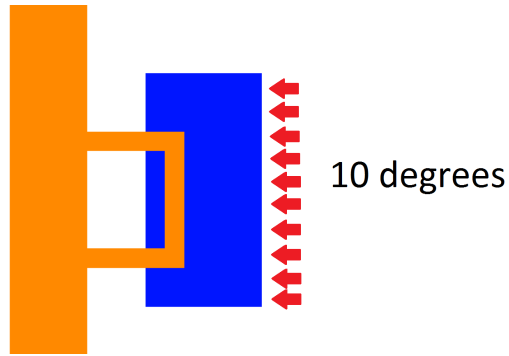
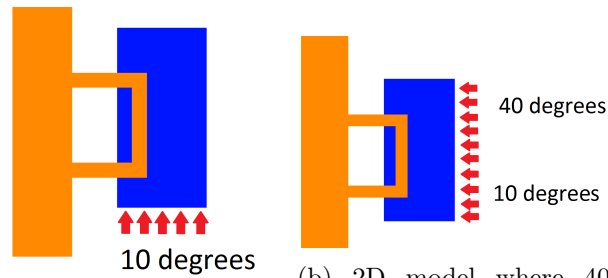

Figure 15: The 2D model where 10 degrees were symmetrically set at the eastern side of the concrete.

As figure 15 illustrates, 10 constant degrees were set symmetrically at the eastern of the concrete for a given time step in the numerical simulation. For the asymmetrically system, two cases were investigated.



(a) The 2D model where 10 degrees were asymmetrically set at the southern side of the concrete.

(b) 2D model where 40 degrees and 10 degrees were asymmetrically set at the eastern side of the concrete.

Figure 16: The two asymmetrically cases for the 2D model, where constant temperature values were set.

As figure 16 displays, two asymmetrically cases were investigated. For the first case (figure 16a), 10 degrees were set asymmetrically for a given time step in the numerical simulation. For the second case (figure 16b), two different degrees were set to give an asymmetric system for a given time step in the numerical simulation. The first degree was set to 40 and the second degree was set to 10 (constant values).

### 3.4.1 Symmetric flux

For the symmetric system, the flux was set at the eastern side of the concrete (recall figure 14a). The time step used in the numerical simulation was set to 9.8 days for the symmetric flux. The results are displayed in the different figures below.

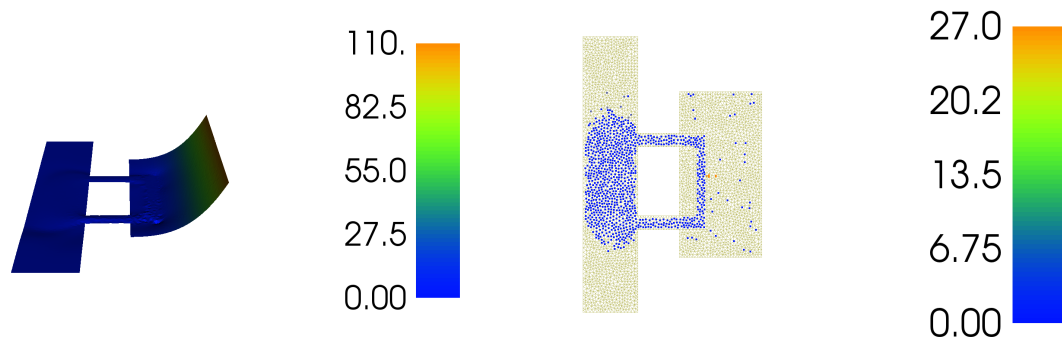

(a) The temperature measurement in the domain after the time step was set to 9.8 days.

(b) The fluid velocity and flow measurements in the domain after the time step was set to 9.8 days.

Figure 17: The temperature and velocity in the system with symmetric flux.

The temperature in figure 17a is odd. The time step in the numerical simulation was set to 9.8 days and it is not correct that the water tank has zero temperature after that period. The velocity (figure 17b) is affected by the temperature in the system. Since the temperature measurements is not correct, the fluid velocity is neither correct. Some of the velocity flow that is inside the concrete can be considered as deviation. However the rest of the velocity should be in the fluid, i.e. every bit of the water tank and the pipes. The graphs drawn in the 5 measurement points are displayed below.

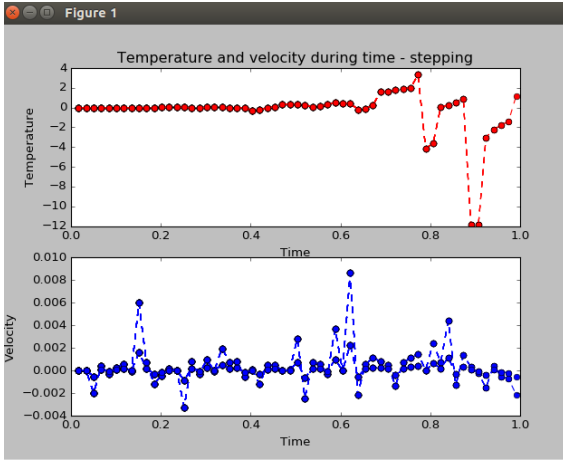

(a) The temperature and the fluid velocity in measurement point 1.

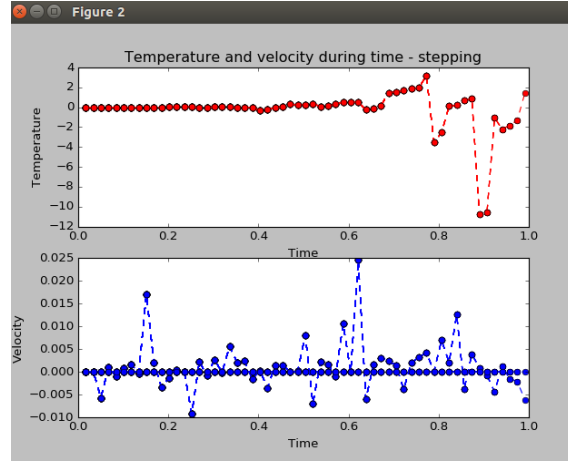

(b) The temperature and the fluid velocity in measurement point 2.

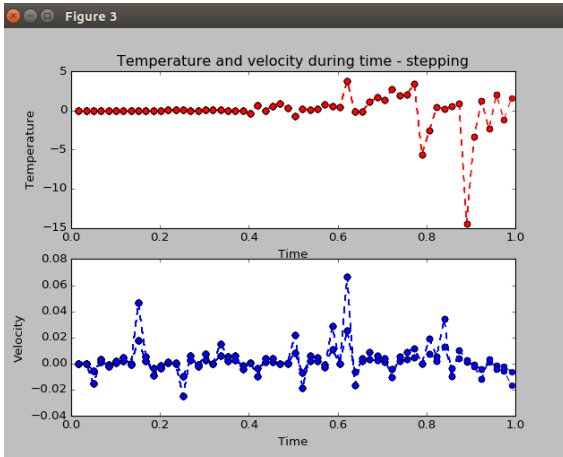

(c) The temperature and the fluid velocity in measurement point 3.

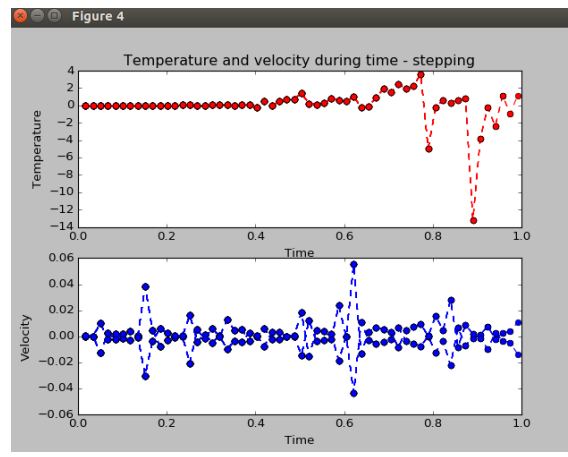

(d) The temperature and the fluid velocity in measurement point 4.

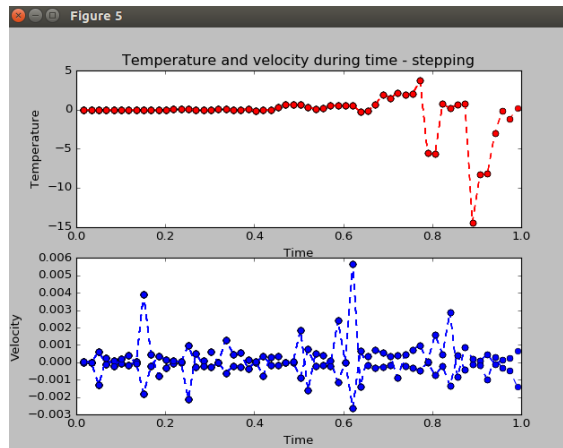

(e) The temperature and the fluid velocity in measurement point 5.

Figure 18: The temperature and the fluid velocity is measured in 5 measurement points for the symmetric flux.

Even though the graphs are not quite correct, the data obtained from them could be analyzed. Figure 18c displays the highest fluid velocity and temperature. This is true since measurement point 3 is the first measurement point that is affected by the flux. It is also true that measurement points 1 and 5 has the lowest fluid velocity and temperature (figure 18a and figure 18e). Measurement points 1 and 5 are the two measurement points which is affected last by the temperature (they are farthest away). Measurement point 4 (figure 18d) has a slightly better result than measurement point 2 (figure 18b).The average temperature over the domain is listed in table 4, where the the average temperature is measured in the whole domain and not just the 5 measurement points.

Time step	Hours	Days	Average temperature
1	6	0.25	0.514
2	12	0.5	1.028
3	18	0.75	1.542
4	24	1.0	2.056
5	30	1.25	2.570
6	36	1.5	3.085
7	42	1.75	3.599
8	48	2.0	4.115
9	54	2.25	4.629
10	60	2.5	5.142
11	66	2.75	5.657
12	72	3.0	6.175
13	78	3.25	6.693
14	84	3.5	7.215
15	90	3.75	7.733
16	96	4.0	8.209
17	102	4.25	8.720
18	108	4.5	9.239
19	114	4.75	9.761
20	120	5.0	10.277
21	126	5.25	10.745
22	132	5.5	11.263
23	138	5.75	11.772
24	144	6.0	12.145
25	150	6.25	12.729
26	156	6.5	13.206
27	162	6.75	13.843
28	168	7.0	14.520
29	174	7.25	15.026
30	180	7.5	15.655
31	186	7.75	15.99
32	192	8.0	16.354
33	198	8.25	16.850
34	204	8.5	17.514
35	210	8.75	18.015
36	216	9.0	18.534
37	222	9.25	19.156
38	228	9.5	19.020
39	234	9.75	19.523
40	240	10.0	20.280

Table 4: Average temperature over the domain for 10 days in the symmetric flux system.

As the table illustrates, the average temperature increases over the whole domain for the symmetric flux during each time step. It is correct that the average temperature increases, but not over such a large time step.

### 3.4.2 Asymmetric flux

For the asymmetric system, the flux was set at the southern side of the concrete (recall figure 14b). The time step used in the numerical simulation was set to 9.8 days for the asymmetric flux. The results are displayed in the different figures below.

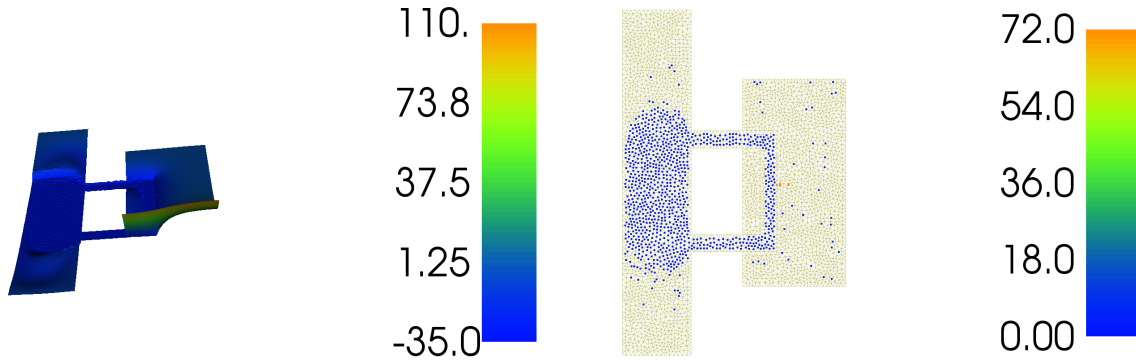

(a) The temperature measurement in the domain after the time step was set to 9.8 days.

(b) The fluid velocity and flow measurements in the domain after the time step was set to 9.8 days.

Figure 19: The temperature and the fluid velocity in the system with asymmetric flux.

Again the temperature in figure 19a is strange. The time step in the numerical simulation was set to 9.8 days and it is not correct that some areas in the fluid has the temperature of -35. The velocity (figure 19b) is affected by the temperature in the system. Even though the numerical simulation contains some missing elements, the displayed figures can be analyzed in a more general manner. Some of the fluid velocity flow that is inside the concrete can be considered as deviation. The information we can gain from figure 19b is that the velocity is significantly higher in an asymmetric system in relation to a symmetric system. The graphs drawn for the 5 measurement points in the asymmetric system is displayed below.

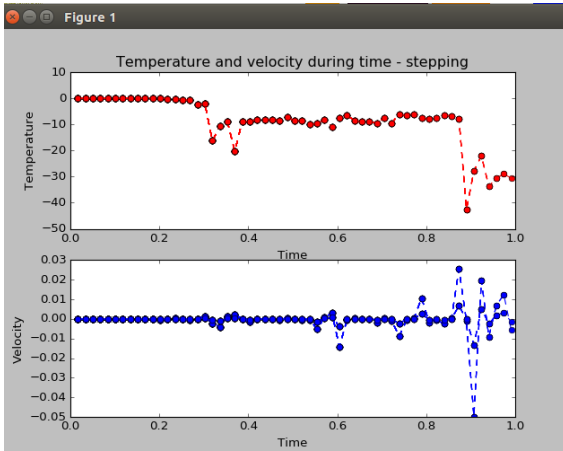

(a) The temperature and the fluid velocity in measurement point 1.

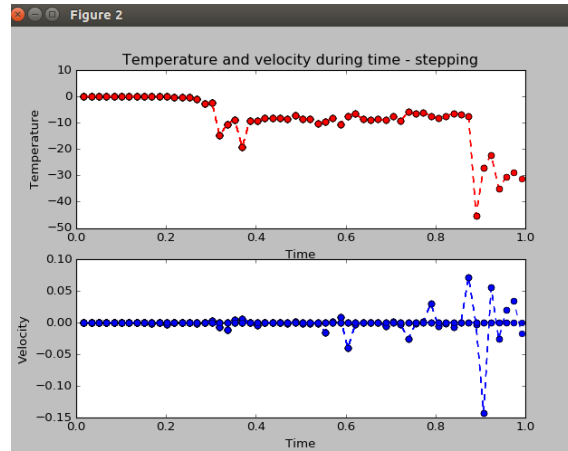

(b) The temperature and the fluid velocity in measurement point 2.

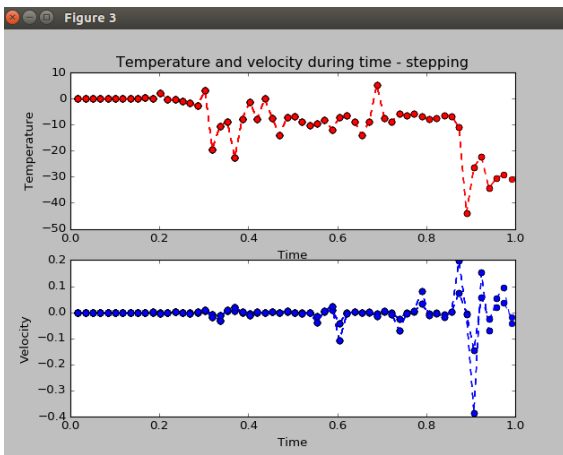

(c) The temperature and the fluid velocity in measurement point 3.

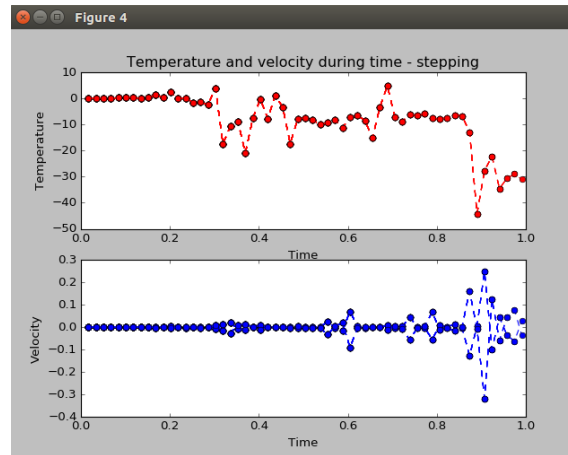

(d) The temperature and the fluid velocity in measurement point 4.

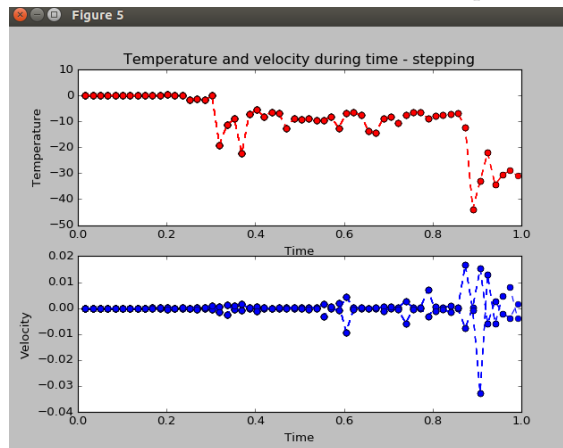

(e) The temperature and the fluid velocity in measurement point 5.

Figure 20: The temperature and the fluid velocity is measured in 5 measurement points for the asymmetric flux.



As seen in figure 20c and figure 20d, the fluid velocity is highest in these measurement points. This is not a deviation since measurement points 3 and 4 are the two points closest to the flux at the given time interval. It is also correct that measurement points 1 and 5 (figure 20a and figure 20e ) has the lowest velocity. Measurement point 5 has a little bit better graph than measurement point 1. Measurement point 1 is the point which is farthest away in this asymmetric flux system (recall from figure 13). As expected, measurement point 2 (figure 20b) has even better results than measurement points 1 and 5. A reason for this is because measurement point 2 experience the flux a bit earlier than measurement points 1 and 5 in this asymmetric system. The average temperature over the domain is listed in table 5, where the the average temperature is measured in the whole domain and not just the 5 measurement points.

Time step	Hours	Days	Average temperature
1	6	0.25	0.257
2	12	0.5	0.514
3	18	0.75	0.771
4	24	1.0	1.028
5	30	1.25	1.293
6	36	1.5	1.560
7	42	1.75	1.811
8	48	2.0	2.055
9	54	2.25	2.309
10	60	2.5	2.647
11	66	2.75	2.841
12	72	3.0	3.321
13	78	3.25	3.223
14	84	3.5	3.461
15	90	3.75	3.066
16	96	4.0	3.248
17	102	4.25	2.863
18	108	4.5	3.822
19	114	4.75	-5.975
20	120	5.0	-3.555
21	126	5.25	-2.648
22	132	5.5	-9.913
23	138	5.75	-3.123
24	144	6.0	-1.982
25	150	6.25	-2.477
26	156	6.5	-1.337
27	162	6.75	-1.421
28	168	7.0	-3.304
29	174	7.25	-1.931
30	180	7.5	-2.141
31	186	7.75	-2.053
32	192	8.0	-2.507
33	198	8.25	-2.361
34	204	8.5	-1.616
35	210	8.75	-3.428
36	216	9.0	-0.956
37	222	9.25	-0.284
38	228	9.5	-0.997
39	234	9.75	-2.622
40	240	10.0	-1.957

Table 5: Average temperature over the domain for 10 days in the asymmetric flux system.

As the table illustrates, after 4 days the average temperature in the domain starts to decrease, which is very strange. It may be the temperature in the fluid that is affecting the average temperature, since the results from the 5 measurement points (which is measured inside the fluid),

have some negative numbers.

### 3.4.3 10 degrees set symmetrically in the system

Again, for the symmetric system, the temperature was set at the eastern side of the concrete (recall figure 15). The time step used in this numerical simulation test was set to 9.8 days. The temperature was set to 10 degrees which means that approximately after 1 hour all the concrete should be warm (section 3.1). The results are displayed in the different figures below.

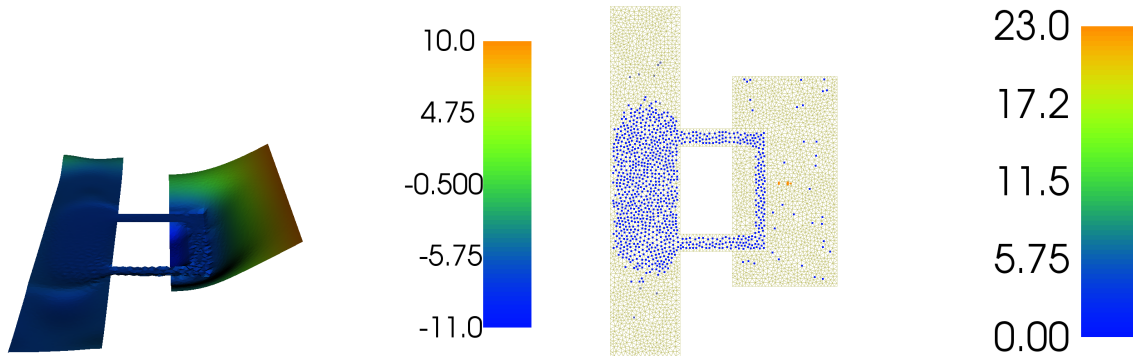

(a) The temperature measurement in the domain after the time step was set to 9.8 days.

(b) The fluid velocity and flow measurements in the domain after the time step was set to 9.8 days.

Figure 21: The temperature and the fluid velocity in the system with 10 degrees symmetrically set at the eastern side of the concrete.

Since there are some errors in the numerical simulation, the temperature and the fluid velocity numbers are a little bit strange. It is odd that some areas in the 2D model has a temperature of -11 after 9.8 days (figure 21a). It is also worth mentioning that the calculations for how much time that is required to get enough energy needed to heat up the concrete (section 3.1), concluded with a time step of approximately 1 hour to warm up this specific concrete volume. However, even after a numerical simulation of 9.8 days, the concrete has still some areas that are cold. The temperature is quite low (constant 10 degrees) and this could be one reason why the symmetric flux gained a higher temperature and fluid velocity after 9.8 days. On the other hand, the 5 measurement points in this case displays that the temperature and the fluid velocity were a little bit better than the symmetric flux during the numerical simulation. Some of the fluid flow is inside the concrete domain, these points could be considered as deviations. However it is strange to understand why just some of the fluid flow is inside the water tank. After 9.8 days there should be a flow everywhere in the fluid sub domain. The 5 measurement points for the temperature and the fluid velocity are displayed in the figure below.

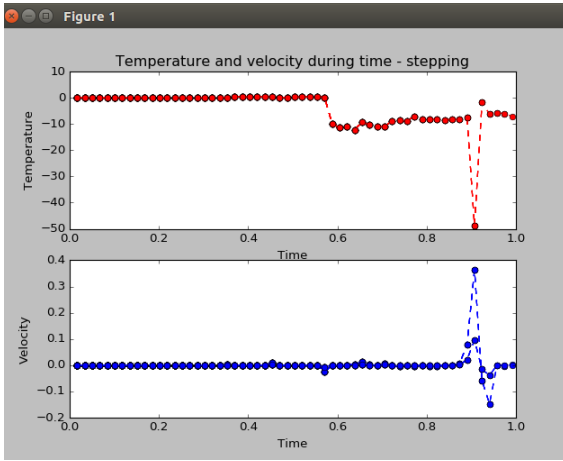

(a) The temperature and the fluid velocity in measurement point 1.

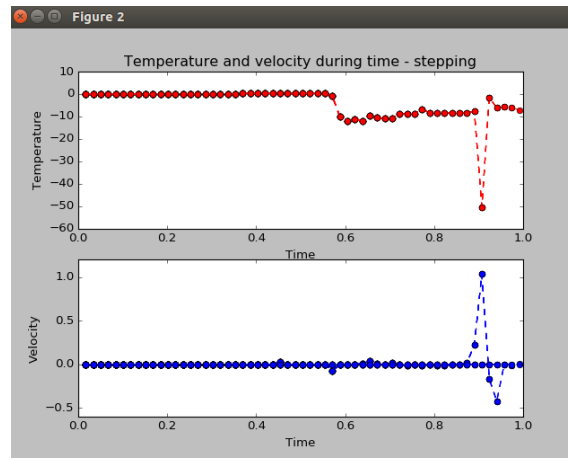

(b) The temperature and the fluid velocity in measurement point 2.

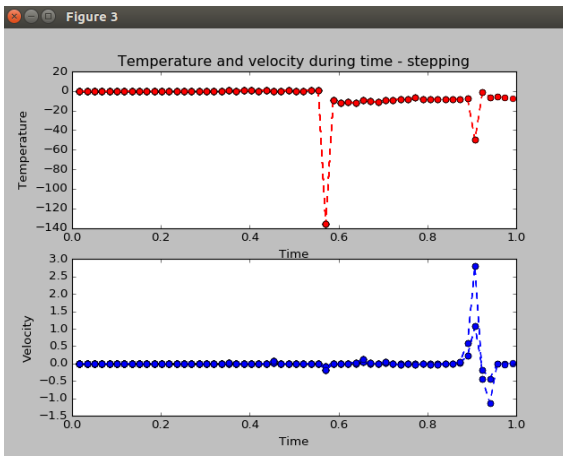

(c) The temperature and the fluid velocity in measurement point 3.

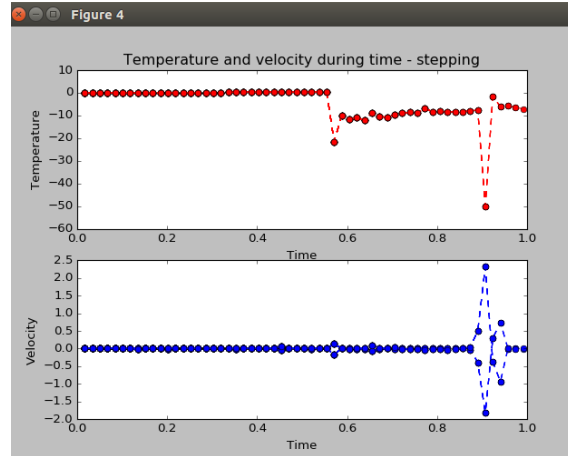

(d) The temperature and the fluid velocity in measurement point 4.

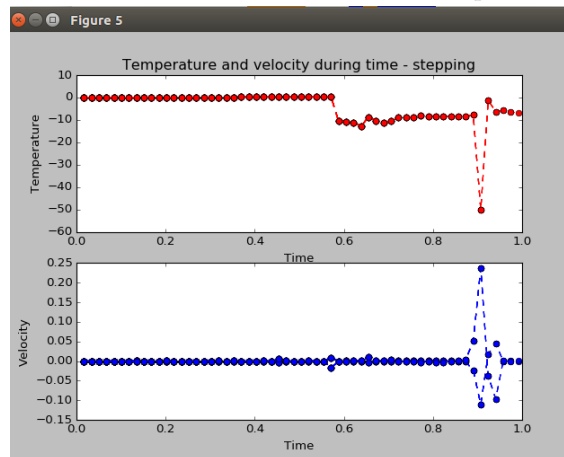

(e) The temperature and the fluid velocity in measurement point 5.

Figure 22: The temperature and fluid velocity is measured in 5 measurement points with 10 constant degrees symmetrically set at the eastern side of the concrete.

Figure 22c has the highest fluid velocity. This is true since measurement point 3 is the first measurement point that is affected by the temperature. It is also true that measurement point 1 and 5 has the lowest velocity and temperature (figure 22a and figure 22e). It is also worth noticing that when a symmetric temperature is applied, the increase in the fluid velocity takes a pretty long time. Figure 22b and figure 22d displays almost similar results. However figure 22d has a slightly better velocity than figure 22b. The average temperature over the domain is listed in table 6, where the the average temperature is measured in the whole domain and not just the 5 measurement points.

Time step	Hours	Days	Average temperature
1	6	0.25	0.424
2	12	0.5	0.624
3	18	0.75	0.776
4	24	1.0	0.904
5	30	1.25	1.016
6	36	1.5	1.117
7	42	1.75	1.210
8	48	2.0	1.296
9	54	2.25	1.376
10	60	2.5	1.452
11	66	2.75	1.525
12	72	3.0	1.595
13	78	3.25	1.664
14	84	3.5	1.731
15	90	3.75	1.797
16	96	4.0	1.854
17	102	4.25	1.912
18	108	4.5	1.970
19	114	4.75	2.031
20	120	5.0	2.104
21	126	5.25	2.169
22	132	5.5	2.335
23	138	5.75	2.391
24	144	6.0	2.448
25	150	6.25	2.478
26	156	6.5	2.540
27	162	6.75	2.581
28	168	7.0	2.578
29	174	7.25	2.640
30	180	7.5	2.678
31	186	7.75	2.720
32	192	8.0	2.813
33	198	8.25	2.865
34	204	8.5	-1.017
35	210	8.75	-5.543
36	216	9.0	-6.315
37	222	9.25	-6.788
38	228	9.5	-7.684
39	234	9.75	-6.110
40	240	10.0	-7.304

Table 6: Average temperature over the domain for 10 days, where 10 degrees was set symmetrically in the system.

As the table illustrates, the average temperature increases slowly before it quickly reduces to negative values. This is strange since there is a constant temperature of 10 degrees. In reality there

should not be any negative numbers, since there is a constant temperature of 10 degrees set in the system.

### 3.4.4 Asymmetric degrees set in the system

Two cases were investigated in the asymmetric system. In the first case, the degree was set to 10 at the southern side of the concrete (recall figure 16a). For both cases, the time step in the numerical simulation were set to 9.8 days. Approximately after 1 hour, all the concrete should be warm (section 3.1). The results are illustrated below:

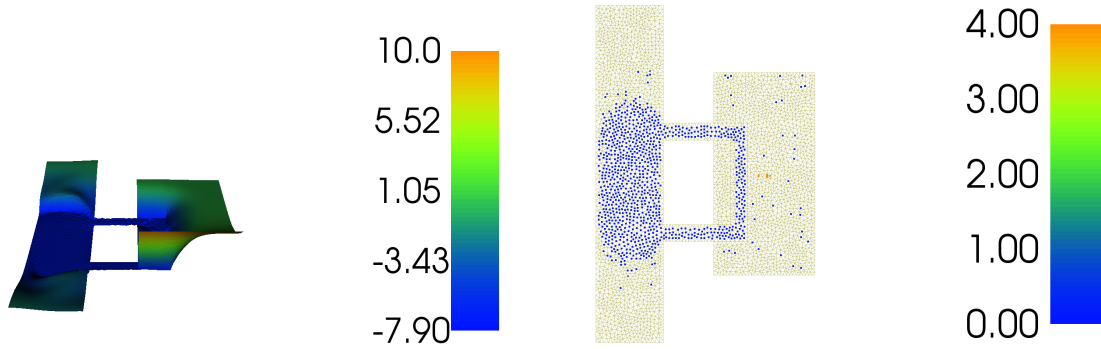

(a) The temperature measurement in the domain after the time step was set to 9.8 days.

(b) The fluid velocity and flow measurements in the domain after the time step was set to 9.8 days.

Figure 23: The temperature and the fluid velocity in the system with 10 degrees symmetrically set at one side.

It is strange that some areas in the 2D model has a temperature of -7.90 after 9.8 days (figure 23a). The concrete has some small areas that is marked as cold. The fluid velocity was pretty stable during the numerical simulation. However the asymmetric model had a much better result than the symmetric model during the numerical simulation. The end results is on the other hand worser than the symmetric model. This tells us that an asymmetric model gives a faster fluid velocity and temperature than a symmetric model. This is better illustrated in the figure 24 below.

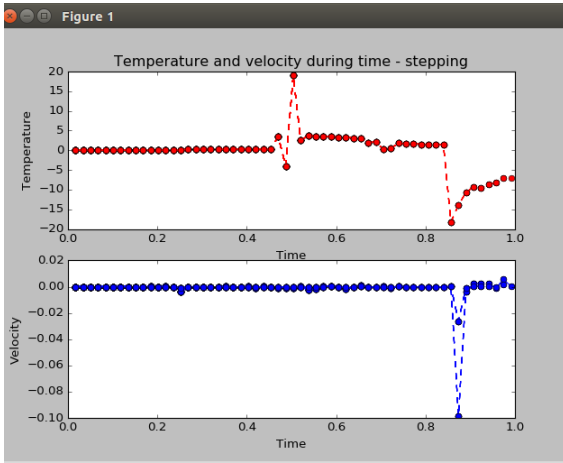

(a) The temperature and the fluid velocity in measurement point 1.

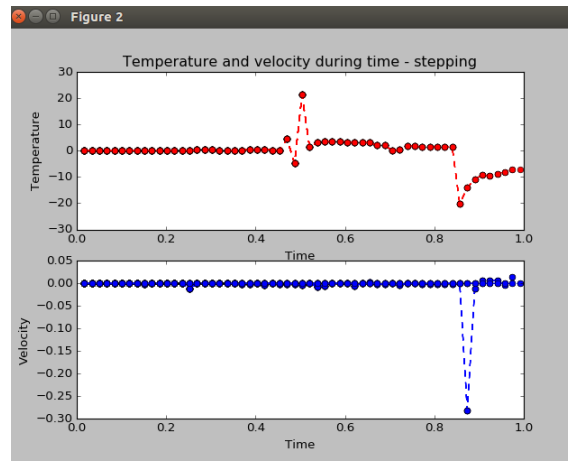

(b) The temperature and the fluid velocity in measurement point 2.

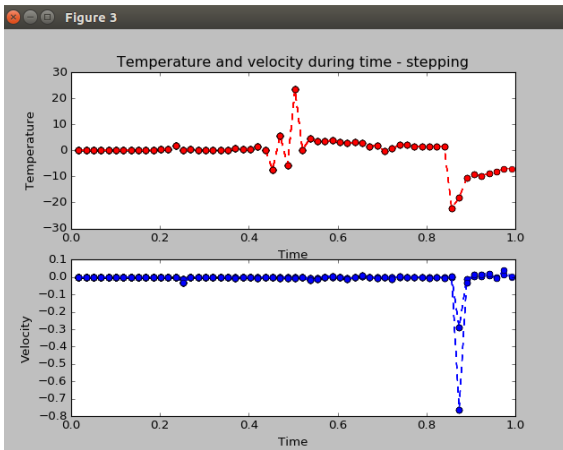

(c) The temperature and the fluid velocity in measurement point 3.

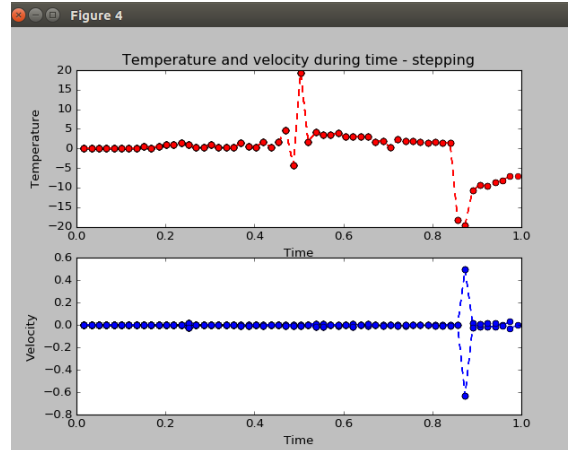

(d) The temperature and the fluid velocity in measurement point 4.

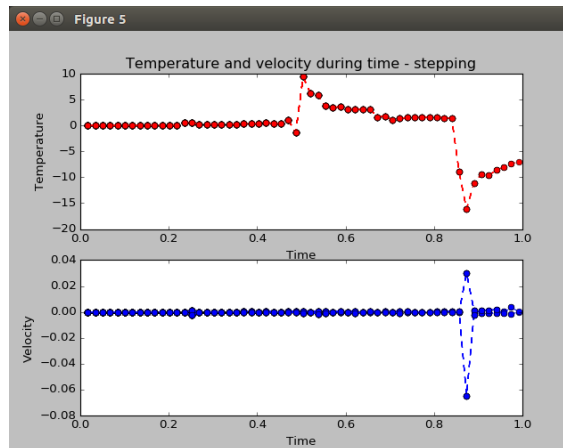

(e) The temperature and the fluid velocity in measurement point 5.

Figure 24: The temperature and the fluid velocity is measured in 5 measurement points with 10 degrees asymmetricly set at the southern side of the concrete.



Figure 24d, figure 24c and figure 24b has the highest temperature, which again gives a higher fluid velocity. The fluid velocity is affected by the temperature and pressure. This is true since these measurement points are affected first by the temperature. It is not hard to understand that measurement point 1 and 5 has the lowest temperature and fluid velocity, since these measurement points are farthest away from the temperature source (figure 24a and figure 24e). The temperature increased quicker in the asymmetric system than in the symmetric system. The average temperature over the domain is listed in table 7, where the the average temperature is measured in the whole domain and not just the 5 measurement points.

Time step	Hours	Days	Average temperature
1	6	0.25	0.212
2	12	0.5	0.312
3	18	0.75	0.388
4	24	1.0	0.452
5	30	1.25	0.510
6	36	1.5	0.561
7	42	1.75	0.607
8	48	2.0	0.647
9	54	2.25	0.709
10	60	2.5	0.726
11	66	2.75	0.791
12	72	3.0	0.890
13	78	3.25	0.925
14	84	3.5	1.075
15	90	3.75	1.063
16	96	4.0	1.102
17	102	4.25	1.122
18	108	4.5	1.166
19	114	4.75	1.165
20	120	5.0	1.173
21	126	5.25	1.193
22	132	5.5	1.297
23	138	5.75	1.285
24	144	6.0	1.313
25	150	6.25	1.474
26	156	6.5	1.336
27	162	6.75	1.634
28	168	7.0	2.724
29	174	7.25	-0.172
30	180	7.5	9.400
31	186	7.75	4.771
32	192	8.0	4.984
33	198	8.25	4.592
34	204	8.5	4.520
35	210	8.75	4.570
36	216	9.0	4.443
37	222	9.25	4.436
38	228	9.5	4.429
39	234	9.75	4.432
40	240	10.0	3.711

Table 7: Average temperature over the domain for 10 days, where 10 degrees was set asymmetrically in the system.

As the table illustrates, the average temperature increases over the whole domain during each time step. Time step 29 and 30 looks like deviations. Other than that, the temperature seems to

increase slowly over the domain.

For final test case two constant degrees were set asymmetrically in the numerical simulation (recall figure 16b). 40 and 10 degrees were set at the eastern side of the concrete.

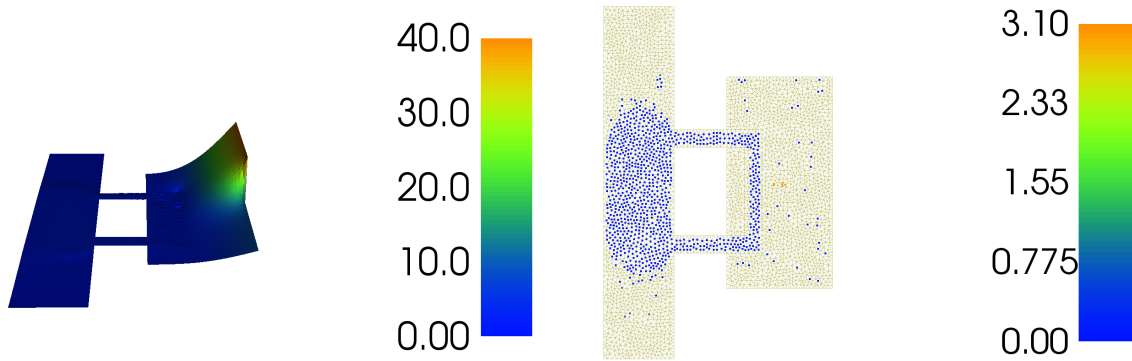

(a) The temperature measurement in the domain after the time step was set to 9.8 days.

(b) The fluid velocity and flow measurements in the domain after the time step was set to 9.8 days.

Figure 25: The temperature and the fluid velocity in the system with 10 and 40 degrees asymmetrically set at the eastern side of the concrete.

As seen in figure 25a the eastern side with 40 degrees dominates over the concrete domain. This is not hard to understand since the other part of the eastern side has only 10 degrees. However since there are some errors in the numerical simulation the outcome is strange. If we completely trust these results, it would take longer than 9.8 days to warm up this small volume of concrete. This is not correct neither in the reality and in the calculations for how much time that is required to get enough energy needed to heat up the concrete. Figure 26 illustrates the temperature and fluid velocity from the final test case.

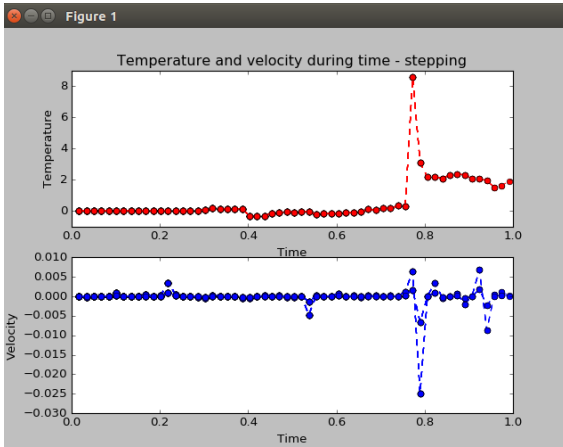

(a) The temperature and the fluid velocity in measurement point 1.

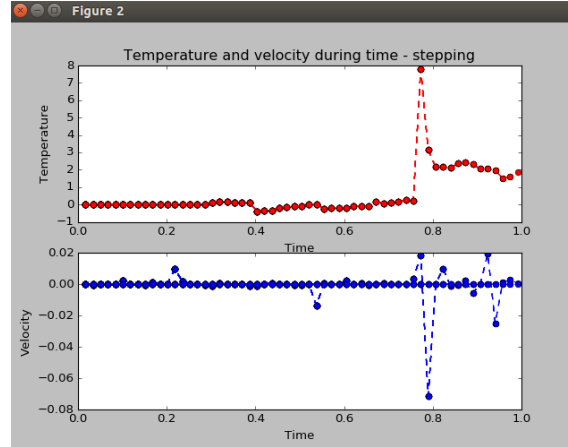

(b) The temperature and the fluid velocity in measurement point 2.

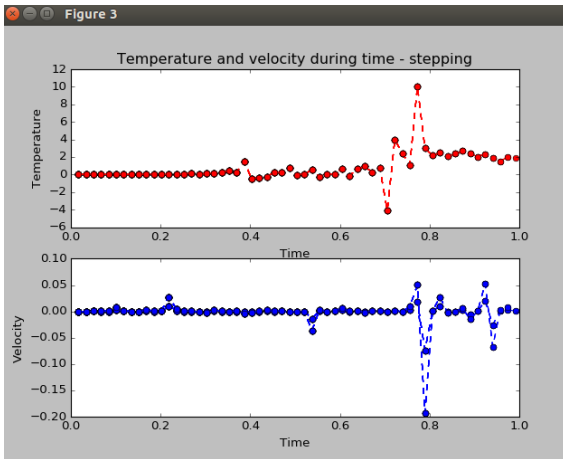

(c) The temperature and the fluid velocity in measurement point 3.

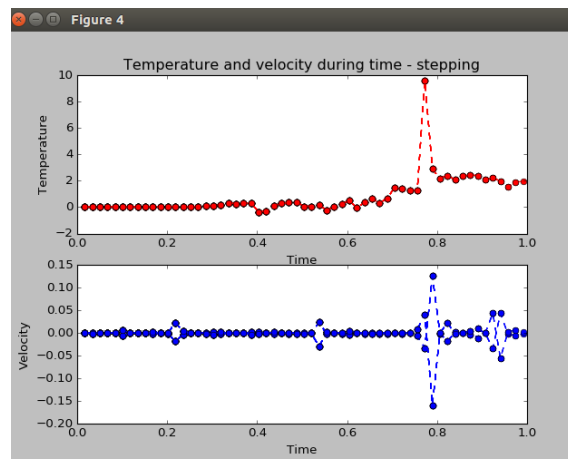

(d) The temperature and the fluid velocity in measurement point 4.

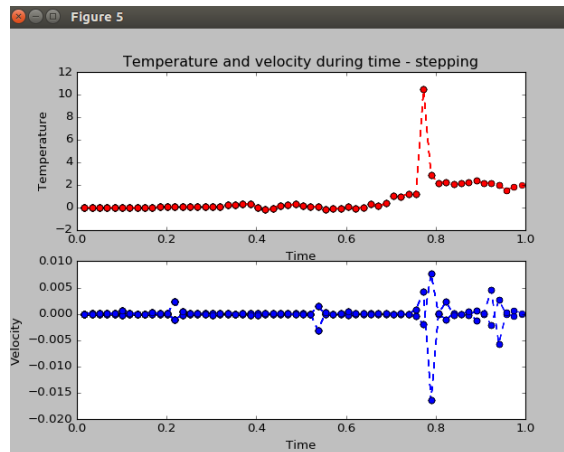

(e) The temperature and the fluid velocity in measurement point 5.

Figure 26: The temperature and the fluid velocity is measured in 5 measurement points with 40 and 10 degrees asymmetricly set at the eastern side of the concrete.

Figure 26c has the highest temperature. Since 40 degrees dominates over 10 degrees, measurement point 2 should have had a better result (figure 26b). It comes as a surprise that measurement point 2 has the worst result with regards to the temperature and fluid velocity (figure 26b). Figure 26e should have had the worst result. For some reason figure 26d has the best fluid velocity. This is not correct since measurement point 3 is the point that hits the temperature source first. Figure 26a has some similar equalities as figure 26b, however figure 26a has poorer result with regards to the fluid velocity. The average temperature over the domain is listed in table 8, where the the average temperature is measured in the whole domain and not just the 5 measurement points.

Time step	Hours	Days	Average temperature
1	6	0.25	1.072
2	12	0.5	1.576
3	18	0.75	1.961
4	24	1.0	2.283
5	30	1.25	2.566
6	36	1.5	2.820
7	42	1.75	3.053
8	48	2.0	3.271
9	54	2.25	3.474
10	60	2.5	3.667
11	66	2.75	3.853
12	72	3.0	4.028
13	78	3.25	4.200
14	84	3.5	4.359
15	90	3.75	4.516
16	96	4.0	4.667
17	102	4.25	4.820
18	108	4.5	4.968
19	114	4.75	5.138
20	120	5.0	5.293
21	126	5.25	5.430
22	132	5.5	5.562
23	138	5.75	5.672
24	144	6.0	5.582
25	150	6.25	5.625
26	156	6.5	5.782
27	162	6.75	5.924
28	168	7.0	6.071
29	174	7.25	6.226
30	180	7.5	6.279
31	186	7.75	6.367
32	192	8.0	6.493
33	198	8.25	6.378
34	204	8.5	6.511
35	210	8.75	6.619
36	216	9.0	6.772
37	222	9.25	6.783
38	228	9.5	6.910
39	234	9.75	7.098
40	240	10.0	7.142

Table 8: Average temperature over the domain for 10 days, where 10 and 40 degrees were set asymmetrically in the system.

As the table illustrates, the average temperature increases over the whole domain during each time step. This test case looks like the most stable case of all the test cases, when it comes

to computing the average temperature over the domain. However, it is strange that the average temperature increases that slowly during this time interval.

### 3.4.5 Diffusion

To test if the diffusion worked in the numerical simulation,  $\beta$  was set to zero:



Figure 27: Diffusion in the 2D model.

As seen in figure 27, the fluid velocity is zero everywhere in the domain. This means that the diffusion works in the numerical simulation.

## 4 Discussion of the results

This section contains a discussion of the results achieved in the thesis. The first subsection presents the modified Stokes equations, the natural convection-diffusion equations and the calculations for how much time that is required to get enough energy needed to heat up the concrete. The final subsection has a discussion of the numerical simulation, where the 3D model and the 2D model were focused on.

### 4.1 The modified Stokes equations, the natural convection-diffusion equations and the required time to heat up the concrete

It is not common that the Stokes equations is connected with the natural convection-diffusion equations. That is why a modified version of the Stokes equations, where the equations were driven by a temperature gradient, was used. In that way, the modified Stokes equations has a connection with the natural convection-diffusion equations, which is the equations for transporting heat. The modified Stokes equations, the natural convection-diffusion equations and the calculations for how much time that is required to get enough energy needed to heat up the concrete, was predicted to have no calculation errors. The calculations in the thesis focus on meters, while the physical experiment used millimeters [2]. The reason why the calculations focuses on meters instead of millimeters is because almost every SI-unit is expressed in meters and not in millimeters. The calculations for how much time that is required to get enough energy needed to heat up the concrete, concluded with approximately 1 and 4 hours. That is, if the temperature was set to 10 degrees or 40 degrees. For this volume of concrete, it is reasonable to think that this suits the reality.

### 4.2 Numerical simulation

The numerical simulation has still some errors when it comes to the 3D models and the 2D model. The numerical simulation of the 3D model and the 2D model is discussed in more detail in the subsection below.

#### 4.2.1 The 3D models and the 2D model

Since the 3D models was the primary focus during the thesis, a lot of time was spent to develop a complete 3D model with the modified Stokes equations and the natural convection-diffusion equations. When the errors occurred (as in figure 12), the first thought was that there might be some mistakes or missing boundary conditions. As time went on, every boundary condition were carefully controlled and adjusted. However, the same flow mistakes occurred. Research information about sub domains for 3D models, concludes with that they are currently under development [13, 14, 15].

Since the 2D model was the secondary focus during the thesis, a much lesser time was spent to develop a complete 2D model with the modified Stokes equations and the natural convection-diffusion equations. This is why the numerical simulation for the 2D model still have some errors. It seems like the errors occurs when the temperature meets the fluid. It can be several reasons why the errors occurs. One reason could be that the size of the mesh has not enough triangles to create adequate points. That is, the mesh is too raw during the numerical simulation. The mesh is currently  $64 \times 64$  squares, which means that there is 4096 squares in the mesh, where each square is divided into two triangles. Another possible error could be the dimensions used in the numerical simulation for the 2D model. In the numerical simulation each 2D shape was drawn without any thought of dimensions. Since a lot of the shapes has a great



distance between the points, it was decided to set them in diameters to create some similar dimensions as the physical experiment. The 2D model worked just fine when it did not have density, viscosity and thermal diffusivity. The errors occurred when these values was implemented and when the dimension had to be specified in the model. The errors in the numerical simulation may come from these conversions. Another error that occurs is when the temperature crosses the border from concrete to fluid. These errors could have something to do with the dimensions or the mesh. In addition, some errors occurred with regards to the flow. These errors comes from the mesh. Some of the points inside the concrete affected the fluid flow. For instance, some of the concrete points were to close to the pipes, which again made the flow go towards the concrete and not follow the pipe system. This happened even though there was the no-slip condition as argument at the boundary. One solution to solve this was to add even more boundary conditions with the no-slip condition as argument. However this method did not remove all the points, which is seen in the figures of the 2D model that describes the fluid velocity flow. In these figures we can clearly see blue points inside the concrete domain (figure 17b, figure 19b, figure 21b, figure 23b and figure 25b).

As it turns out, an asymmetric system has a better solution than a symmetric system, with regards to the fluid velocity. It appears like when an asymmetric system is used, the temperature and the fluid velocity happens much faster than in a symmetric system.

## 5 Concluding remarks

This section is the final section of the report, which sums up the Master thesis. The section contains two subsections, where one is for the conclusion and the second is for the recommendations for future work.

### 5.1 Conclusion

The topic investigated in this Master thesis is fairly new. Since the physical experiment measured a very low fluid velocity, the thesis focused on laminar flow [2]. The modified Stokes equations were used for the fluid velocity, while the natural convection-diffusion equations were used for the heat transport. The physics calculations were used to compare the energy needed per degree in reality versus the outcome from the different numerical simulations. The modified Stokes equations used in this thesis, applies for a system that expects low fluid velocity. The modified Stokes equations can be further implemented in other system where such expected outcome is predicted. The natural convection-diffusion equations can be used in a system that is not driven by any external sources. In this case, the flux and the different temperature gradients worked as sources for the heat transport. Since the numerical simulation is dependent on time, a time discretization which uses a finite difference approximation were applied in the modified Stokes equations and the natural convection-diffusion equations. It is also important to mention that the physical experiment used millimeters for dimensions, while the different equations applied in the thesis used meters for measuring dimensions [2]. The numerical simulation used diameters as the dimension for the different shapes created for the 2D model. 5 cases were investigated for the temperature gradient. 1 case for the asymmetric and symmetric flux system, 2 cases for the asymmetric temperature that was set to be a constant degree(s) and 1 case for the symmetric temperature that was set to be a constant degree. The numerical simulation had 5 measurement points inside the fluid sub domain, that measured the fluid velocity in the X and the Y direction. The 5 points also measured the temperature in the fluid sub domain. Currently the numerical simulation has some errors that needs to be fixed in order to gain more correct results. However, during the numerical simulation the asymmetric system proved to be much more efficient than the symmetric system. The equations presented in this thesis can be used in a system that is driven by natural convection. The results from the experimentation and implementation, showed that there were room for improvements, especially in relation to the numerical simulation. However the results also showed good potential particularly when it comes to the different equations applied in the report.

### 5.2 Recommendations for future work

Recommendations for future work is listed down below:

- Solve the errors in the 2D model when physical values are implemented in the modified Stokes equations and the natural convection-diffusion equations.
- Make a finer mesh in the numerical simulation.
- Check the dimension in the numerical simulation.
- Remove the existing point that is in the concrete in the numerical simulation
- Solve the error when the temperature crosses the border from concrete to fluid in the numerical simulation.

- Implement a better solver in the numerical simulation.

For the first item in the list, the errors that occurred when the density, viscosity, thermal diffusivity and dimensions were applied needs to be solved. For the second item, another error source could be that the mesh is currently too raw ( $64 \times 64$ ). This could be solved by increasing the number of squares in the mesh. However, when a finer mesh is applied, the numerical simulations usually takes a longer time. For the third item, the dimensions needs to be carefully checked and validated with the modified Stokes equations, the natural convection-diffusion equations and the boundary conditions. The fourth item in the list is needed to be solved to get a more correct fluid flow. If it is not solved, the existing points inside the concrete would most likely disturb the fluid flow direction. The fifth item in the list could come from the previously mentioned errors. If the error continue to occur when the other items are solved, there could be something wrong with the implementation of the modified Stokes equations, the natural convection-diffusion equations or even the sub domains that decides which part of the domain that is fluid and concrete. For the sixth item in the list, a better solver for the numerical simulation could be implemented. The solver that is currently used in the numerical simulation, takes too long time to simulate the results. If the time interval goes for several months, the currently used solver would use a very long time to compute the results.

## References

- [1] The Engineering ToolBox. Thermal conductivity of common materials and gases, March 2017. [www.engineeringtoolbox.com/thermal-conductivity-d\\_429.html](http://www.engineeringtoolbox.com/thermal-conductivity-d_429.html) , [Online; Accessed 05-25-2017].
- [2] Trond Fagerjord. Utnyttelse av solenergi i betong. Bachelor thesis, Høgskolen i Narvik, May 2013.
- [3] Viscopedia. Water, November 2016. <http://www.viscopedia.com/viscosity-tables/substances/water/>, [Online; Accessed 05-25-2017].
- [4] International Atomic Energy Agency. Natural circulation phenomena and modelling for advanced water cooled reactors. Technical document, International Atomic Energy Agency, March 2012. [http://www-pub.iaea.org/MTCD/Publications/PDF/TE-1677\\_web.pdf](http://www-pub.iaea.org/MTCD/Publications/PDF/TE-1677_web.pdf), [Online; Accessed 03-26-2017].
- [5] Dr. Andrew Sleight. Laminar and turbulent flow, November 2016. [http://www.efm.leeds.ac.uk/CIVE/CIVE1400/Section4/laminar\\_turbulent.htm](http://www.efm.leeds.ac.uk/CIVE/CIVE1400/Section4/laminar_turbulent.htm), [Online; Accessed 01-12-2017].
- [6] M. Bahrami. Forced convection heat transfer, February 2006. <http://www.sfu.ca/~mbahrami/ENSC%20388/Notes/Forced%20Convection.pdf>, [Online; Accessed 01-12-2017].
- [7] P.K. Vijayan and A.K. Nayak. Joint ictp-iaea course on natural circulation phenomena and passive safety systems in advanced water cooled reactors. Lecture notes, International Centre for Theoretical Physics, May 2010. <http://indico.ictp.it/event/a09155/session/4/contribution/4/material/0/0.pdf>, [Online; Accessed 03-26-2017].
- [8] FENICS PROJECT. A gallery of finite element solvers, August 2016. [https://fenicsproject.org/pub/tutorial/html/\\_ftut1006.html#ch:fundamentals:diffusion](https://fenicsproject.org/pub/tutorial/html/_ftut1006.html#ch:fundamentals:diffusion), [Online; Accessed 03-13-2017].
- [9] FENICS PROJECT. Fenics project, May 2017. <https://fenicsproject.org/>, [Online; Accessed 05-31-2017].
- [10] Python Software Foundation. Dofin 2016.1.0, 1990-2017. <https://pypi.python.org/pypi/DOLFIN>, [Online; Accessed 05-31-2017].
- [11] Oracle. Welcome to virtualbox.org!, May 2017. <https://www.virtualbox.org/>, [Online; Accessed 05-31-2017].
- [12] Susanne C. Brenner and L. Ridgeway Scott. *The Mathematical Theory of Finite Element Methods*. Springer Science + Business Media and LLC, 233 Spring Street, New York, NY 10013, USA, 3 edition, 2008.
- [13] Fredrik Lingvall and Benjamin Kehlet. Current state of fenics 3d subdomain support?, March 2017.

- <https://groups.google.com/forum/#!topic/fenics-support/Ghbzb6z3dp4>, [Online;  
Accessed 05-9-2017].
- [14] FEniCS Question and Answer. Subdomains in 3d, September 2016.  
<https://fenicsproject.org/qa/5630/subdomains-in-3d?show=5630#q5630>, [Online;  
Accessed 05-9-2017].
- [15] FEniCS Question and Answer. Interior subdomain edges in 3d meshes, September 2016.  
<https://fenicsproject.org/qa/5630/subdomains-in-3d?show=5630#q5630>, [Online;  
Accessed 05-9-2017].

**Appendix A**

**Project description**

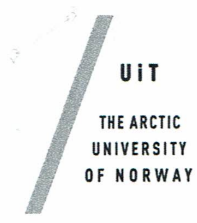

Faculty of Engineering Science and Technology  
Department of Computer Science and Computational Engineering  
UiT The Arctic University of Norway

# Modeling and Simulation of Heat Transfer in Blocks with Thin Pipes

**Renate Karlsen**

*Thesis for Master of Science in Computer Science*



---

## Background

Experiments have been carried out in the laboratory at Narvik University College in collaboration with Norut Narvik, in which a thin pipe filled with water was partly embedded inside a block of concrete that was under the influence of an external heat source [1]. Temperature measurements have been made. The purpose of these experiments has been to develop our understanding of possible applications to effective energy transfer from high heat capacity parts of buildings. There is a need to better understand the outcome of the experiment both in theory and for practical numerical simulation. Such knowledge could be valuable in the design process of solutions for passive energy transfer technology.

## Problem description

The goal of this project is to model and simulate energy transport in concrete with thin pipes carrying fluids. With the physical experiment as a basis a numerical simulation is to be carried out and be validated/calibrated. Identification of important design parameters is a second objective.

## The work shall include:

1. A model of the energy transport.
2. A numerical simulation of the energy transport.
3. An analysis of the agreement between the experimental data and the numerically obtained data.
4. An analysis of which design parameters are deciding for the heat driven flow within the system.

## References

[1] Trond Fagerjord. Utnyttelse av solenergi i betong. Hovedprosjekt, Høgskolen i Narvik, Bachelor i Teknologi, Studieretning Allmenn Bygg. 2013.

## Dates

Date of distributing the task:	09.01.2017
Date for submission (deadline):	06.06.2017

## Contact information

Candidate	Renate Karlsen rka043@post.uit.no
Adviser at UiT-IVT	Klas Pettersson klas.pettersson@uit.no
Adviser at UiT-IVT	Hung Thanh Nguyen Hung.thanh.nguyen@uit.no



---

## General information

### **This master thesis should include:**

- ※ Preliminary work/literature study related to actual topic
  - A state-of-the-art investigation
  - An analysis of requirement specifications, definitions, design requirements, given standards or norms, guidelines and practical experience etc.
  - Description concerning limitations and size of the task/project
  - Estimated time schedule for the project/ thesis
- ※ Selection & investigation of actual materials
- ※ Development (creating a model or model concept)
- ※ Experimental work (planned in the preliminary work/literature study part)
- ※ Suggestion for future work/development

### **Preliminary work/literature study**

After the task description has been distributed to the candidate a preliminary study should be completed within 4 weeks. It should include bullet points 1 and 2 in "The work shall include", and a plan of the progress. The preliminary study may be submitted as a separate report or "natural" incorporated in the main thesis report. A plan of progress and a deviation report (gap report) can be added as an appendix to the thesis.

**In any case the preliminary study report/part must be accepted by the supervisor before the student can continue with the rest of the master thesis.** In the evaluation of this thesis emphasis will be placed on the thorough documentation of the work performed.

### **Reporting requirements**

The thesis should be submitted as a research report and could include the following parts; Abstract, Introduction, Material & Methods, Results & Discussion, Conclusions, Acknowledgements, Bibliography, References and Appendices. Choices should be well documented with evidence, references, or logical arguments.

The candidate should in this thesis strive to make the report survey-able, testable, accessible, well written, and documented.

Materials which are developed during the project (thesis) such as software/codes or physical equipment are considered to be a part of this paper (thesis). Documentation for correct use of such information should be added, as far as possible, to this paper (thesis).

The text for this task should be added as an appendix to the report (thesis).

### **General project requirements**

If the tasks or the problems are performed in close cooperation with an external company, the candidate should follow the guidelines or other directives given by the management of the company.

The candidate does not have the authority to enter or access external companies' information system, production equipment or likewise. If such should be necessary for solving the task in a satisfactory way a detailed permission should be given by the management in the company before any action are made.

---

Any travel cost, printing and phone cost must be covered by the candidate themselves, if and only if, this is not covered by an agreement between the candidate and the management in the enterprises.

If the candidate enters some unexpected problems or challenges during the work with the tasks and these will cause changes to the work plan, it should be addressed to the supervisor at the UiT or the person which is responsible, without any delay in time.

**Submission requirements**

This thesis should result in a final report with an electronic copy (i.e. CD/DVD, memory stick) of the report included appendices and necessary software codes, simulations and calculations. The final report with its appendices will be the basis for the evaluation and grading of the thesis. The report with all materials should be delivered in one signed loose leaf copy, together with three bound. If there is an external company that needs a copy of the thesis, the candidate must arrange this. A standard front page, which can be found on the UiT internet site, should be used. Otherwise, refer to the "General guidelines for thesis" and the subject description for master thesis.

The final report with its appendices should be submitted no later than the decided final date. The final report should be delivered to the adviser at the office of the IVT Faculty at the UiT.

## Etiske retningslinjer for veiledning ved UiT Norges arktiske universitet

Fastsatt av	Styret ved UiT Norges arktiske universitet (UiT)	Dato: 27.10.2016
Ansvarlige avdelinger:	AFU/UTA	Id: 2016/7526, jf. 5823

Retningslinjene gjelder for veiledning på bachelor- master- og ph.d.-nivå og skal vedlegges veiledningskontrakten.

UiT har det overordnede ansvaret for veiledningen.

### 1. Veileder skal sikre at studenten får god faglig støtte i sitt arbeid

- a Veileders faglige kompetanse skal stå til disposisjon for studenten.
- b Veileder skal følge studentens arbeid og holde seg fortløpende orientert om framdriften.
- c Veileder skal hjelpe studenten å komme i kontakt med andre forskere og miljøer med særlig kompetanse innen det aktuelle forskningsområdet.

### 2. Både veileder og student skal gjøre sitt beste for å sikre et kvalitativt godt resultat

- a Veileder skal være oppmerksom på og handle dersom et prosjekt ser ut til å ikke la seg realisere, eller om tegn tyder på at studenten vil ha problem med å gjennomføre det.
- b Studenten skal være innstilt på å satse fullt ut i forhold til den tid og anstrengelse som studiet krever.
- c Studenten skal være åpen og mottagelig for veileders innspill.
- d Studenten skal gi veileder fullt innblikk i arbeidet og dets fremdrift, og ta imot råd av veileder på et tidlig stadium dersom det oppstår problemer.

### 3. Veileder og student har et felles ansvar for at veiledningen foregår i tilfredsstillende former

- a Veileder skal gi samarbeidet med studenten den prioritet som følger av å ta på seg veilederansvar.
- b Veileder og student har begge ansvar for å holde regelmessig kontakt slik partene er blitt enige om.
- c Veileder skal bestrebe seg på å få lest de tekster studenten leverer så snart hun/han har anledning.
- d Om veileder ikke har tid til å lese en tekst omgående, skal studenten informeres om dette, og få beskjed om når teksten vil være lest.
- e Veileder og student har begge ansvar for å være godt forberedt til veiledningen.
- f Veileder skal overholde avtalt tid når studenten kommer til veiledning, og sørge for at samtalen kan føres uforstyrret (stenge telefonen etc.).
- g Veileder skal sørge for tilfredsstillende oppfølging av veiledning under eget fravær (i forskningsterminer e.l.).
- h Studenten skal anstrenge seg for å holde frister og gjennomføre arbeidsoppgaver slik man er blitt enig om i veiledningen.
- i Studenten skal levere tekster for lesing i rimelig tid før avtalt veiledningsmøte.

### 4. Veileder og student har begge ansvar for at arbeidet gjennomføres med faglig integritet

- a Veileder skal formidle de forskningsetiske grunnregler som gjelder for faget.



- b Veileder skal være oppmerksom på, og veilede i forskningsetiske spørsmål knyttet til studentens arbeid.
- c Studenten skal sette seg inn i og følge fagets forskningsetiske normer, og be om råd fra veileder dersom han/hun er i tvil.
- d Dersom veileder ønsker å anvende studentens datamateriale eller forskningsresultater i egne publikasjoner eller forskning, må han/hun innhente tillatelse fra studenten og følge den skikk og bruk som gjelder for kildehenvisninger og kreditering av andres bidrag.
- e De vanlige reglene for medforfatterskap, slik de går fram av nasjonale og internasjonale retningslinjer, gjelder. Et veilederforhold gir ikke grunnlag for medforfatterskap i seg selv.

**5. Begge parter skal vise respekt for den andre partens personlige integritet, og avstå fra enhver handling eller uttalelse som kan oppfattes som krenkende**

- a Veileder har hovedansvaret for at veiledningen foregår i saklige og profesjonelle former, og bør være bevisst på den autoritetsposisjon som veilederrollen gir i forhold til studenten.
- b Veileder skal avstå fra alle kommentarer om studenten, personlig, fysisk eller kjønnsmessig.
- c Studenten skal vise tilsvarende respekt for veileder som person.
- d Veileder må ikke utnytte sin autoritetsposisjon til å oppnå fordeler i forhold til studenten, eller til å oppnå private tjenester eller ytelser.

**6. Informasjon av personlig og fortrolig art som har blitt formidlet i sammenheng med veiledningen, skal behandles av begge parter med diskresjon**

- a Veileder skal unngå å diskutere interne kollegiale forhold med studenten.
- b Veileder skal ikke diskutere studentens anliggender med andre studenter.
- c Studenten skal utvise tilsvarende hensyn overfor veileder.

**7. Private relasjoner som er uforenlige med den faglige relasjonen bør ikke forekomme**

- a Det påhviler veileder å sørge for at den nødvendige profesjonelle distansen opprettholdes, og unngå situasjoner som kan lede til at den forrykkes.
- b Veileder og student skal ikke ha nære familiære relasjoner eller felles privatøkonomiske interesser. De skal heller ikke ha en seksuell relasjon eller være i et parforhold med hverandre.
- c Om et parforhold oppstår, skal institutt- eller fakultetsledelsen informeres og veiledningsrelasjonen avbrytes.
- d Om veileder og student har et privat vennskapsforhold, skal begge parter være oppmerksomme på viktigheten av tydelige grenser mellom det profesjonelle og det private.
- e Veileder skal ikke motta noen form for honorar for veiledningen utover det som er avtalt med universitetet.

**8. Veileder og student har et felles ansvar for å løse konflikter**

- a Begge parter kan ta opp problemer med samarbeidet eller fremdriften, og anstrenge seg for å bidra til en konstruktiv løsning.
- b Fakultetet har ansvar for og skal ha rutiner for å løse en eventuell konflikt mellom veileder og student som partene ikke kan løse på egen hånd.
- c Om veileder og student ser seg tvunget til å bryte veiledningsrelasjonen, skal fakultetet ta ansvar for å håndtere bytte av veileder på en ryddig og tilfredsstillende måte.

**Appendix B**

**Plan of progress**

Date	Day	Week	Start	End	Duration	Goals	January	Description
08:01:17	Sunday	1						
08:01:17	Monday	1						
08:01:17	Tuesday	1						
08:01:17	Wednesday	1						
08:01:17	Thursday	1						
08:01:17	Friday	1						
08:01:17	Saturday	1	10:00	13:30	3:30	Read the lecture notes by T.F.	Read and took notes from the lecture notes by T.F.	Did the seminar and the beginning of Stokes flow
08:01:17	Sunday	1						
08:01:17	Monday	2	8:00	14:30	6:30	Goal from 08:01:17 done. Do some ANSYS tests.	Done some ANSYS tests. Work on Stokes flow and convection-diffusion flow. Did some tests on ANSYS and got the error fixed.	Worked with ANSYS and did the Python examples. Almost done with the Python code.
08:01:17	Tuesday	2	8:00	16:30	8:30	Continue working with ANSYS. Python examples. Read the documentation.	Continued working with ANSYS. Python examples. Read the documentation.	Goal from 08:01:17 done. Did some experiments with ParaView and ANSYS. Created a table with time and error boundary and repositioned the fence code change.
08:01:17	Wednesday	2	8:00	19:30	11:30	Do the goal from 08:01:17. Test with ParaView.	Did the goal from 08:01:17. Test with ParaView.	Read and took notes from a convection-diffusion article. Almost done with reading chapter 9 carefully. Did not have time to model fluid and 2D block in ParaView.
08:01:17	Thursday	2	8:00	19:30	11:30	Read chapter 9 in Fluid Mechanics. Model fluid. 2D block in ParaView.	Read and took notes from a convection-diffusion article. Almost done with reading chapter 9 carefully. Did not have time to model fluid and 2D block in ParaView.	Worked with Jupyter and OpenFOAM. Started to read chapter 12, but did not have time to read the chapters from the lecture and the book book.
08:01:17	Friday	2	8:00	19:30	11:30	Chapter 12 in Fluid. Read the chapters in preparation for the other book and the black book.	Worked with Jupyter and OpenFOAM. Started to read chapter 12, but did not have time to read the chapters from the lecture and the book book.	
08:01:17	Saturday	2						
08:01:17	Sunday	2	8:00	11:00	3:00	Be done with chapter 12 and the mixed problem section from the yellow book.	Read chapter 12 and 6.2 mixed problem section from the yellow book.	
08:01:17	Monday	3	8:30	14:00	5:30	Read the chapters in the black book (chapt. 10-19).	Read chapter 12 and 6.2 mixed problem section from the yellow book.	
08:01:17	Tuesday	3	8:00	19:30	11:30	Do the goal from 08:01:17. Work with Stokes without time on paper and FECS. Read 12.3 in Inhomogeneous and try to understand Stokes. Check FECS implementation with T.F. that	Read chapter 12 and 6.2 mixed problem section from the yellow book.	
08:01:17	Wednesday	3	8:00	14:00	6:00	Work with goal from 17:01:17 on paper.	Worked with the goal from 17:01:17.	
08:01:17	Thursday	3	8:00	19:30	11:30	Work with goal from 17:01:17 on paper.	Worked with the goal from 17:01:17.	
08:01:17	Friday	3	8:00	19:30	11:30	Work with goal from 17:01:17 on paper.	Worked with the Stokes equations for steady flow (see Notes).	
08:01:17	Saturday	3						
08:01:17	Sunday	3						
08:01:17	Monday	4	8:00	19:30	11:30	Work with goal from 17:01:17 on paper.	Worked with the Stokes equations for steady flow in LaTeX. DONE proving	
08:01:17	Tuesday	4	8:00	19:30	11:30	Work with goal from 17:01:17 on FECS.	Worked with the Stokes equations, did not work.	
08:01:17	Wednesday	4	8:00	19:30	11:30	Work with goal from 17:01:17 on FECS.	Worked with the Stokes equations, did not work.	
08:01:17	Thursday	4	8:00	19:30	11:30	Work with goal from 17:01:17 on FECS and start with Stokes dependent on time.	Worked with the Stokes equations, did not work.	
08:01:17	Friday	4	8:00	19:30	11:30	Work with Stokes dependent on time.	Worked with the Stokes equations, did not work.	
08:01:17	Saturday	4						
08:01:17	Sunday	4						
08:01:17	Monday	5	8:00	19:30	11:30	Work with Stokes dependent on time.	Worked with the Stokes equations, did not work.	
08:01:17	Tuesday	5	8:00	14:00	6:00	Work with Stokes dependent on time.	Worked with the Stokes equations, did not work.	
<b>TOTAL HOURS DURING JANUARY:</b>							<b>122:30</b>	
01:02:17	Wednesday		8:00	19:30	11:30	Work with Stokes dependent on time.	Worked with the Stokes equations, did not work.	
02:02:17	Thursday		8:00	19:30	11:30	Work with convection-diffusion.	Worked with the Stokes equations, did not work.	
03:02:17	Friday		8:00	14:00	6:00	Work with convection-diffusion and Stokes equations.	Worked with the Stokes equations, did not work.	
04:02:17	Saturday							
05:02:17	Sunday							
06:02:17	Monday	6	8:00	19:30	11:30	Combining convection-diffusion and Stokes equations in FECS.	Worked with the Stokes equations, did not work.	
07:02:17	Tuesday	6	8:00	14:00	6:00	Combining convection-diffusion and Stokes equations in FECS.	Worked with the Stokes equations, did not work.	
08:02:17	Wednesday	6	8:00	19:30	11:30	Combining convection-diffusion and Stokes equations in FECS.	Worked with the Stokes equations, did not work.	
09:02:17	Thursday	6	8:00	14:00	6:00	Combining convection-diffusion and Stokes equations in FECS.	Worked with the Stokes equations, did not work.	
10:02:17	Friday	6						
11:02:17	Saturday	6						
12:02:17	Sunday	6						
13:02:17	Monday	7	8:00	19:30	11:30	Combining convection-diffusion and Stokes equations in FECS.	Worked with the Stokes equations, did not work.	
14:02:17	Tuesday	7	8:00	19:30	11:30	Combining convection-diffusion and Stokes equations in FECS.	Worked with the Stokes equations, did not work.	
15:02:17	Wednesday	7	8:00	19:30	11:30	Combining convection-diffusion and Stokes equations in FECS.	Worked with the Stokes equations, did not work.	
16:02:17	Thursday	7	8:00	19:30	11:30	Combining convection-diffusion and Stokes equations in FECS.	Worked with the Stokes equations, did not work.	
17:02:17	Friday	7	8:00	19:30	11:30	Combining convection-diffusion and Stokes equations in FECS.	Worked with the Stokes equations, did not work.	
18:02:17	Saturday	7						
19:02:17	Sunday	7						
20:02:17	Monday	8	8:00	19:30	11:30	Combining convection-diffusion and Stokes equations in FECS.	Worked with the Stokes equations, did not work.	
21:02:17	Tuesday	8	8:00	19:30	11:30	Combining convection-diffusion and Stokes equations in FECS.	Worked with the Stokes equations, did not work.	
22:02:17	Wednesday	8	8:00	14:00	6:00	Add subroutines.	Worked with subroutines.	
23:02:17	Thursday	8	8:00	14:00	6:00	Add subroutines.	Worked with subroutines.	
24:02:17	Friday	8	8:00	19:30	11:30	Add subroutines.	Worked with subroutines.	
25:02:17	Saturday	8						
26:02:17	Sunday	8						
27:02:17	Monday	9	8:00	19:30	11:30	Work with convection-diffusion and Stokes in subroutines.	Worked with the Stokes equations, did not work.	
28:02:17	Tuesday	9	8:00	14:00	6:00	Work with convection-diffusion and Stokes in subroutines.	Worked with the Stokes equations, did not work.	
<b>TOTAL HOURS DURING FEBRUARY:</b>							<b>123</b>	
01:03:17	Wednesday		8:00	19:30	11:30	Work with convection-diffusion and Stokes in subroutines.	Worked with the Stokes equations, did not work.	
02:03:17	Thursday		8:00	19:30	11:30	Work with convection-diffusion and Stokes in subroutines.	Worked with the Stokes equations, did not work.	
03:03:17	Friday		8:00	19:30	11:30	Work with convection-diffusion and Stokes in subroutines.	Worked with the Stokes equations, did not work.	
04:03:17	Saturday							
05:03:17	Sunday							
06:03:17	Monday	10	8:00	19:30	11:30	Work with convection-diffusion and Stokes in subroutines.	Worked with the Stokes equations, did not work.	
07:03:17	Tuesday	10	8:00	19:30	11:30	Read about natural convection.	Worked with the Stokes equations, did not work.	
08:03:17	Wednesday	10	8:00	19:30	11:30	Read about natural convection.	Worked with the Stokes equations, did not work.	
09:03:17	Thursday	10	8:00	19:30	11:30	Read about natural convection.	Worked with the Stokes equations, did not work.	
10:03:17	Friday	10	8:00	19:30	11:30	Read about natural convection.	Worked with the Stokes equations, did not work.	
11:03:17	Saturday	10						
12:03:17	Sunday	10						
13:03:17	Monday	11	8:00	19:30	11:30	Make notes about convection-diffusion and Stokes and make program in FECS.	Worked with the Stokes equations, did not work.	
14:03:17	Tuesday	11	8:00	19:30	11:30	Make notes about convection-diffusion and Stokes and make program in FECS.	Worked with the Stokes equations, did not work.	
15:03:17	Wednesday	11	8:00	14:00	6:00	Make notes about convection-diffusion and Stokes and make program in FECS.	Worked with the Stokes equations, did not work.	
16:03:17	Thursday	11	8:00	19:30	11:30	Make notes about convection-diffusion and Stokes and make program in FECS.	Worked with the Stokes equations, did not work.	
17:03:17	Friday	11	8:00	19:30	11:30	Make notes about convection-diffusion and Stokes and make program in FECS.	Worked with the Stokes equations, did not work.	
18:03:17	Saturday	11						
19:03:17	Sunday	11						
20:03:17	Monday	12	8:00	14:00	6:00	Create FECS program about Stokes and convection-diffusion.	Worked in FECS.	
21:03:17	Tuesday	12	8:00	14:00	6:00	Create FECS program about Stokes and convection-diffusion.	Worked in FECS.	
22:03:17	Wednesday	12	8:00	14:00	6:00	Create FECS program about Stokes and convection-diffusion.	Worked in FECS.	
23:03:17	Thursday	12	11:00	15:00	4:00	Create FECS program about Stokes and convection-diffusion.	Worked in FECS.	
24:03:17	Friday	12	8:00	12:00	4:00	Create FECS program about Stokes and convection-diffusion.	Worked in FECS.	
25:03:17	Saturday	12						
26:03:17	Sunday	12						
27:03:17	Monday	13	8:00	14:00	6:00	Read about natural convection.	Worked with the Stokes equations, did not work.	
28:03:17	Tuesday	13	8:00	14:00	6:00	Worked in FECS.	Worked in FECS.	
29:03:17	Wednesday	13	8:00	14:00	6:00	Worked in FECS.	Worked in FECS.	
30:03:17	Thursday	13	8:00	14:00	6:00	Worked in FECS.	Worked in FECS.	
31:03:17	Friday	13	8:00	14:00	6:00	Worked in FECS.	Worked in FECS.	
<b>TOTAL HOURS DURING MARCH:</b>							<b>116</b>	

April									
01.04.17	Saturday								
02.04.17	Sunday								
03.04.17	Monday	14	8:00	15:00	7:1	Secondary conditions for 3D	Worked with boundary conditions 3D		
04.04.17	Tuesday					2D implementation of the experiment	subdomains in 3D		
05.04.17	Wednesday					2D implementation of the experiment	subdomains in 3D		
06.04.17	Thursday					2D implementation of the experiment	subdomains in 3D		
07.04.17	Friday					2D implementation of the experiment	subdomains in 3D		
08.04.17	Saturday								
09.04.17	Sunday								
10.04.17	Monday	16	8:00	14:30	5:1	2D implementation of the experiment	subdomains in 3D		
11.04.17	Tuesday					2D implementation of the experiment	subdomains in 3D		
12.04.17	Wednesday								
13.04.17	Thursday								
14.04.17	Friday								
15.04.17	Saturday								
16.04.17	Sunday								
17.04.17	Monday	16							
18.04.17	Tuesday		8:00	14:00	0:1	2D implementation of the experiment	subdomains in 3D		
19.04.17	Wednesday			14:00	0:1	2D implementation of the experiment	subdomains in 3D		
20.04.17	Thursday		8:00	12:00	4:1	2D implementation of the experiment	subdomains in 3D		
21.04.17	Friday		8:00	12:30	7:1	2D implementation of the experiment	subdomains in 3D		
22.04.17	Saturday								
23.04.17	Sunday								
24.04.17	Monday	17	8:00	14:00	0:1	2D implementation of the experiment	subdomains in 3D		
25.04.17	Tuesday		8:00	15:30	7:5	2D implementation of the experiment	subdomains in 3D		
26.04.17	Wednesday		8:00	16:30	5:1	2D implementation of the experiment	subdomains in 3D		
27.04.17	Thursday		8:00	14:00	0:1	2D implementation of the experiment	subdomains in 3D		
28.04.17	Friday		8:00	14:00	0:1	2D implementation of the experiment	subdomains in 3D		
29.04.17	Saturday								
30.04.17	Sunday								
TOTAL HOURS DURING APRIL: 105									
May									
01.05.17	Monday	18	8:00	14:00	0:1	2D implementation of the experiment	Worked in FEM/CS with 2D implementation of the experiment		
02.05.17	Tuesday			14:00	0:1	2D implementation of the experiment	subdomains in 3D		
03.05.17	Wednesday		8:00	16:00	0:1	2D implementation of the experiment	subdomains in 3D		
04.05.17	Thursday		8:00	12:00	7:1	2D implementation of the experiment	subdomains in 3D		
05.05.17	Friday		8:00	14:00	0:1	2D implementation of the experiment	subdomains in 3D		
06.05.17	Saturday								
07.05.17	Sunday								
08.05.17	Monday	19	8:00	12:30	7:1	2D implementation of the experiment	SUBDOMAINS IN 3D IS STILL NOT WORKING		
09.05.17	Tuesday		8:00	15:00	7:1	2D implementation of the experiment	No support for subdomains in 3D		
10.05.17	Wednesday		8:00	12:30	7:1	2D implementation of the experiment	Worked in FEM/CS with 2D implementation of the experiment		
11.05.17	Thursday		8:00	16:00	0:1	2D implementation of the experiment	Worked in FEM/CS with 2D implementation of the experiment		
12.05.17	Friday		8:00	15:00	7:1	2D implementation of the experiment	Worked in FEM/CS with 2D implementation of the experiment		
13.05.17	Saturday								
14.05.17	Sunday								
15.05.17	Monday	20	8:00	14:00	0:1	2D implementation of the experiment	Worked in FEM/CS with 2D implementation of the experiment		
16.05.17	Tuesday		8:00	14:00	0:1	2D implementation of the experiment	Worked in FEM/CS with 2D implementation of the experiment		
17.05.17	Wednesday								
18.05.17	Thursday		8:00	16:00	0:1	2D implementation of the experiment	Worked in FEM/CS with 2D implementation of the experiment		
19.05.17	Friday		8:00	15:00	7:1	2D implementation of the experiment	Worked in FEM/CS with 2D implementation of the experiment		
20.05.17	Saturday								
21.05.17	Sunday								
22.05.17	Monday	21	8:00	15:00	7:1	2D implementation of the experiment	Worked in FEM/CS with 2D implementation of the experiment		
23.05.17	Tuesday			15:00	7:1	2D implementation of the experiment	Worked in FEM/CS with 2D implementation of the experiment		
24.05.17	Wednesday		8:00	14:00	0:1	2D implementation of the experiment	Worked in FEM/CS with 2D implementation of the experiment		
25.05.17	Thursday		8:00	12:00	5:1	2D implementation of the experiment	Worked in FEM/CS with 2D implementation of the experiment		
26.05.17	Friday		8:00	15:00	7:1	2D implementation of the experiment	Worked in FEM/CS with 2D implementation of the experiment		
27.05.17	Saturday		8:00	12:00	5:1	Report	Report		
28.05.17	Sunday					Report	Report		
29.05.17	Monday	22		16:00	0:1	Report	Report		
30.05.17	Tuesday		8:00	16:00	0:1	Report	Report		
31.05.17	Wednesday		8:00	16:00	0:1	Report	Report		
TOTAL HOURS DURING MAY: 121.5									
01.06.17	Thursday		8:00	16:00	0:1	Report	Report		
02.06.17	Friday		8:00	16:00	0:1	Report	Report		
03.06.17	Saturday		8:00	16:00	0:1	Report	Report		
04.06.17	Sunday	23	8:30	14:00	5:1	Report	Report		
05.06.17	Monday		8:30	20:00	11:5:1	Report	Report		
06.06.17	Tuesday		8:00	12:00	4:1	Delivery of the report	Deliver the report		
Total hours: 681.25									

## Appendix C

### Source code

The source code consists of 5 files; asymmetric flux, asymmetric temperature case 1, asymmetric temperature case 2, symmetric flux and symmetric temperature. The first file has the asymmetric flux implemented at the southern side of the concrete. The second file has the asymmetric temperature case 1 implemented, where 10 degrees was set asymmetrically at the southern side of the concrete. The third file has the asymmetric temperature case 2 implemented, where 40 and 10 degrees was set asymmetrically at the eastern side of the concrete. The fourth file has the symmetric flux implemented at the eastern side of the concrete. The final file has the symmetrically temperature implemented, where 10 degrees was set at the eastern side of the concrete. All the work that was put into the 3D models is currently unavailable. The 3D models had large errors, because the developers of FEniCS has not yet included sub domain support for 3D models. The author did not want to submit these files since there are some major components missing.

All the 2D model files are currently under development and has some errors. The source code is available at: [https://source.uit.no/rka043/Master\\_thesis/tree/master](https://source.uit.no/rka043/Master_thesis/tree/master)