



Faculty of Health Sciences
Department of Community Medicine

Three Essays on Subjective Well-being and Preference-Weighted Health

—
Admassu N. Lamu

A dissertation for the degree of Philosophiae Doctor – September 2017

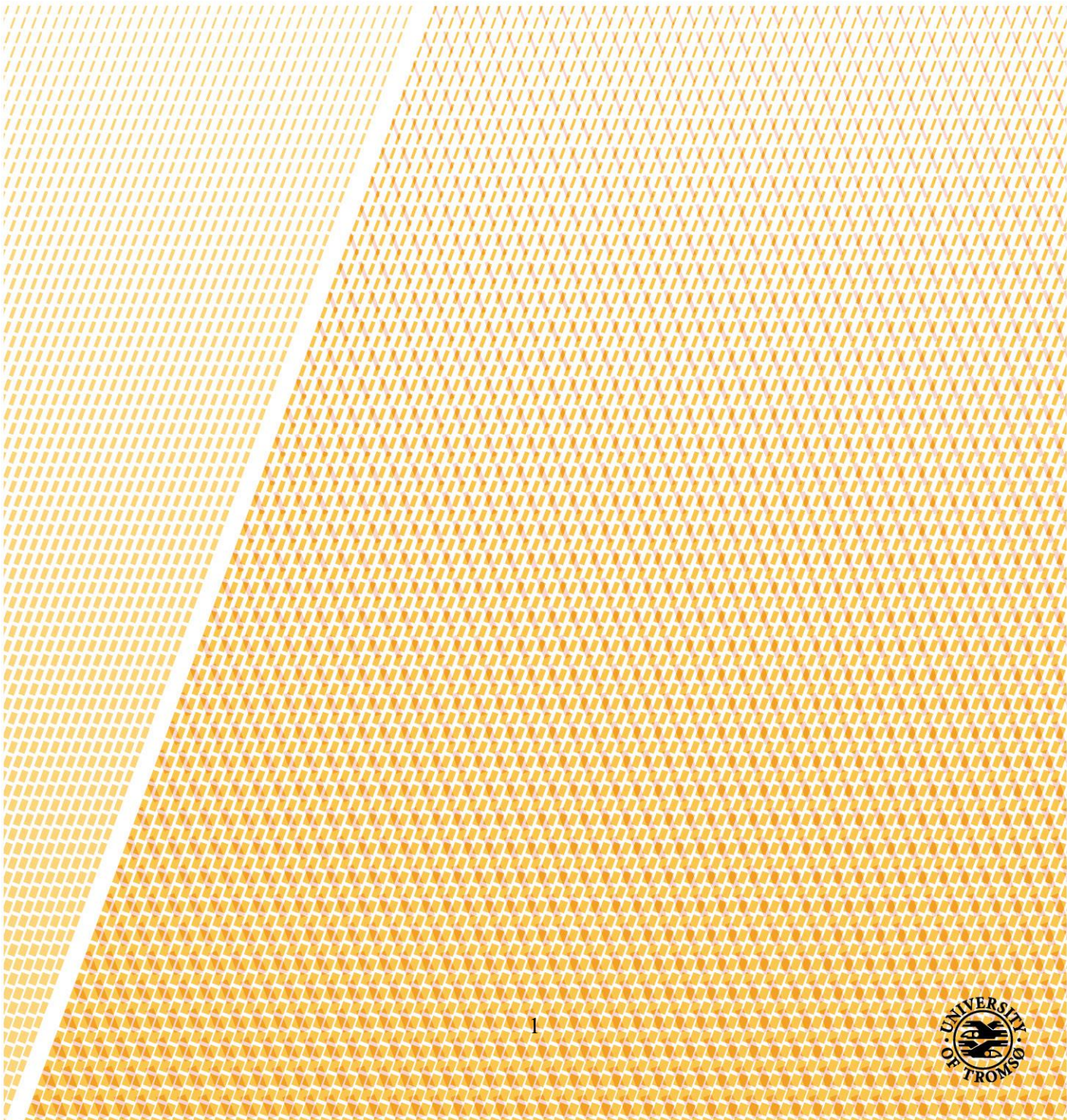

Table of Contents

Acknowledgments	iii
List of abbreviations	iv
List of publications	v
Abstract	vi
1 Introduction	1
2 Background.....	4
2.1 Health-related quality of life	4
2.1.1 Concepts and definitions	4
2.1.2 The need for measuring health outcomes	4
2.1.3 The structure of health-related quality of life measures	5
2.1.4 Generic preference-based measures	6
2.2 Subjective well-being	13
2.2.1 Definition and concepts.....	13
2.2.2 Measuring subjective well-being.....	14
2.2.3 Determinants of subjective well-being.....	16
3 Objectives.....	21
4 Materials and methods.....	22
4.1 Description of the data	22
4.2 Measures of variables.....	23
4.3 Statistical analyses.....	28
4.3.1 Testing the importance of preference-weighting.....	28
4.3.2 Testing the relative importance of health, income, and social relationships	29
4.3.3 Checking the intrinsic vs. the instrumental value of health.....	31
4.4 Missing information	32
5 Summary of results.....	34
5.1 Does preference-weighting matter?.....	34
5.2 Relative contribution of health, income, and social relationships.....	35
5.3 The intrinsic and instrumental value of health	37
6 Discussion.....	39
6.1 Methodological reflections.....	39
6.1.1 Study design	39
6.1.2 Reliability and validity of health-related quality of life and subjective well-being	39
6.1.3 Systematic errors and missingness	42

6.2	Discussion of results.....	43
7	Conclusions and policy implications	51
7.1	Conclusions	51
7.2	Policy implications and further research	52
8	References	54
9	Papers 1-3	67
10	Appendices	

Acknowledgments

This dissertation would not have been possible without the help, advice and encouragement from so many people. I have been extremely grateful for all of them.

First, I would like to thank Jan Abel Olsen for absolute first rate supervision. He has always made himself available to provide me splendid guidance in my academic development. I have taken great pleasure from our many meetings and he has never failed to inspire me. I am also in great debt to John Brazier, Jeff Richardson and Gang Chen who have been pivotal in providing constructive comments and who helped me develop so many of the ideas in the papers included in this thesis.

I would also like to thank my coauthor, Thor Gamst-Klaussen, for his valuable contribution in the first scientific paper included in this thesis. Thor and I were working on the same project sharing the same office. I am always grateful for the wonderful time we had together. I greatly appreciate our useful discussions related to our research project, which, in one way or another, incorporated into this work.

I would also like to thank the Department of Community Medicine at the University of Tromsø (UiT) for providing me an excellent academic environment in which to pursue my PhD study. Everyone in the Department has been hugely supportive and I would like to thank them for lifting my spirits on many a grey day. My gratitude also goes to The Australian National Health and Medical Research Council, UiT, and The Research Council of Norway for their support in collection of data and the preparation of manuscripts included in this thesis.

There are also many close friends who have shared with me both the good and bad times during my PhD study. Particularly, my most heartfelt thanks go to Kebebew N. Ameyu, and Tesfaye H. Leta, who have been indispensable companions throughout the years in my PhD study. Thank you for your relentless love and support, and for listening to my moans in the journey of my life. I would also like to thank everyone I have ever had a conversation with about my research and for helping me to stay passionate about what I do.

Finally, I'd like to thank my family for their support and patience.

List of abbreviations

15D	Fifteen Dimensional Questionnaire
AQoL	Assessment of Quality of Life
D-39	Diabetes-39 Questionnaire
DCE	Discrete Choice Experiment
EQ-5D	European Quality of Life (EuroQol) five Dimensional Questionnaire
HRQoL	Health Related Quality of Life
HSU	Health State Utility
HUI2/3	Health Utility Index mark 2 or mark 3
K-10	Kessler Psychological Distress scale
MAR	Missing At Random
MAU	Multi Attribute Utility
MIC	Multi Instrument Comparison
OECD	Organization for Economic Cooperation and Development
QALY	Quality Adjusted-Life Year
QoL	Quality of Life
QWB-SA	Self-Assessed Quality of Well-Being Scale
RMA	Reduced Major Axis
SEM	Structural Equation Model
SF-36	36-item Short Form Questionnaire
SF-6D	Short Form six Dimensional Questionnaire
SG	Standard Gamble
SWB	Subjective Well-Being
SWLS	Satisfaction With Life Scale
TTO	Time Trade-Off
VAS	Visual Analogue Scale
WHO	World Health Organization

List of publications

All papers included in this thesis have been published during the period of the PhD study. Copyright of these papers resides with the publishers, but under the terms of the copyright agreements these papers are reprinted with kind permission of the publishers of the respective journals. These papers are as follows:

1. Lamu AN, Gamst-Klaussen T, Olsen JA (2017). Preference weighting of health state values: What difference does it make, and why? *Value Health* 20(3), 451-457.
<https://doi.org/10.1016/j.jval.2016.10.002>.
2. Lamu AN, Olsen JA (2016). The relative importance of health, income and social relations for subjective well-being: An integrative analysis. *Soc Sci Med.* 152:176-85.
doi: <https://10.1016/j.socscimed.2016.01.046>.
3. Lamu AN, Olsen JA (2017). Yes, health is important, but as much for its importance via social life: The direct and indirect effects of health on subjective well-being in chronically ill individuals. *Health Economics.* 1–14. DOI: 10.1002/hec.3536.

Abstract

This thesis aims to: i) explore the importance of preference-weighting in health state utility (HSU) instruments and ii) examine the contribution of policy-relevant factors to subjective well-being (SWB). The analyses herein are based on an international sample of individuals aged 18 and above, and this thesis comprises three papers. Paper 1 examined the relative importance of preference-weighting in two contrasting instruments: the shortest, but most widely-used instrument, the EuroQol five dimensional questionnaire (EQ-5D), and the more comprehensive 15 dimensional questionnaire (15D). Based on the findings of Paper 1, the effect of both weighted and unweighted health-related quality of life (HRQoL) measures on SWB were investigated in two follow-up papers: Paper 2 looked into the relative importance of health, income, and social relationships for SWB; Paper 3 continued to examine the link between health and SWB, and the mediating role that income and social relationships play in this link.

The issue of preference-weighting was examined in Paper 1 in terms of construct validity and level of agreement between preference-weighted and unweighted values for each instrument. The results showed that the preference-weighted and unweighted values performed equally well in terms of both convergent and known-group validities. When the visual analogue scale (VAS) was applied, the correlation coefficients of both preference-weighted and unweighted values were quite large (above 0.60) for each instrument. This thesis showed that both weighted and unweighted measures of the EQ-5D and the 15D showed evidence of known-group validity to detect significant differences between known-group variables, such as standard of living and depression. Furthermore, the level of agreement between preference-weighted and unweighted values was very high in both the EQ-5D and the 15D when the preference-weighted and unweighted values were given on the same scale. This indicates that the importance of preference-weighting is small, at least at the group level.

In Paper 2, the relative importance of health, income, and social relationships was analysed after controlling for socio-demographic variables, such as age, gender, marital status, education level, and employment status, as well as disease and country variables. Five alternative HRQoL measures were applied: four HSU instruments (EQ-5D, short-form six dimensional questionnaire [SF-6D], health utility index mark 3 [HUI3], 15D) and one direct measure of HRQoL (VAS). Depending on which HRQoL measure was applied, all of the

aforementioned variables explained about 45-50% of variations in SWB. This implies that the remaining variation could be explained by other omitted variables, such as personality traits and genetic factors. The findings revealed that, in decreasing order of importance, social relationships, health, and income were significantly associated with SWB. The direct measure of HRQoL (VAS) had more influence on SWB than the indirect measures (HSU instruments). Social relationships accounted for nearly half of the total explained variation in SWB, while health accounted for at most one-third. Income accounted for only 7% of the variation, but it was positively significant. The results further revealed that the proportion of effects explained by these variables varied across levels of SWB distributions. The largest contributions were observed at the lower level of SWB.

Results from Paper 3 showed that health influences SWB directly and indirectly via income and social relationships. The effect via income, though significant, was weaker. When measure by the SF-6D, it appeared that more than 50% of the total effect of health was transmitted via social relationships. Thus, the novel finding is that health is important for SWB, but as much for its importance through social relationships.

1 Introduction

Health and subjective well-being (SWB) are multi-faceted concepts, and there is no single indicator that can adequately assess them on a countrywide or international level. However, the World Health Organisation (WHO) has defined *health* as ‘a state of complete physical, mental and social well-being and not merely the absence of disease or infirmity’ [1]. The term SWB reflects both the cognitive and affective evaluations that individuals have about their life, including aspects of physical and mental health [2, 3]. From these definitions, it is evident that health and SWB are highly intertwined. Physical and mental problems, as well as ill health, undermine quality of life and occasionally shorten people’s lives. Such health problems also inhibit economic and social development by depriving society of valuable human capital. Long and healthy lives are therefore not just overarching personal aims for most people; they are a universally-accepted measure of overall well-being.

Recent years have shown a proliferation of studies using various measures of SWB [4, 5], and studies on SWB have become part of the larger academic area of social indicators and quality-of-life research. In addition to increasing academic interest, in the last decade, there has been an increasing interest in the measurement of SWB and the use of these measures for policy purposes. The recent French Commission on the Measurement of Economic Performance and Social Progress (the Stiglitz Commission) [3] and the UK’s increasing interest in measuring SWB for policy purposes [6, 7] represent some of the many calls for broader measures of societal well-being.

Theoretical and empirical analyses of SWB have been progressing to the point that SWB data now enable researchers to investigate some key determinants of SWB. Several studies have gained important insights into these determinants like income [8, 9], health [9, 10], social network [11, 12], and socio-demographic factors [13]. Numerous studies have suggested that the association between income and SWB is generally positive, but diminishes with increasing income [14-16]. Despite the role of social context and individual-level effects, the literature has revealed a strong and stable effect of social relationships on SWB [11, 17]. Though the size of health effects on SWB varies depending on the health measures applied, health has a significant, generally positive effect on SWB. Expert-rated health is less correlated with SWB than self-rated health [18]. Unemployment [4], genetic factors [19, 20], personality traits [21, 22], and other socio-demographic factors such as age, gender, marital

status, and education are important correlates of SWB (for detailed reviews, see Dolan *et al.* [13] and Huppert [23]).

Most previous studies used self-rated health to study the association between health and SWB. Few studies used more detailed, descriptive systems such as health state utility (HSU) instruments. However, the application of these instruments is not straightforward, and a distinction should be made between preference-weighted and unweighted values to determine whether scaling using preferences from the general population introduces any difference. Thus, Paper 1 investigated the extent to which preference-weighted values differ from their unweighted counterparts. It focused on two HSU instruments: the EQ-5D-5L and the 15D, but the argument and their implication could be relevant to other health state descriptive systems. Previous studies have looked into the importance and statistical implications of preference-weighting in the EuroQol five dimensional questionnaire three level (EQ-5D-3L) and the health utility index mark 3 (HUI3) [24-26]. However, Paper 1 was the first study to empirically evaluate the relative importance of preference-weighting for the EQ-5D-5L and the 15D by addressing the scale effect introduced by various elicitation techniques. Scale difference was accounted for by linearly adjusting the unweighted values onto the same scale as that of the EQ-5D-5L and the 15D.

Papers 2 and 3 focused on health, income, and social relationships in relation to SWB. Indeed, these determinants appeared to be most relevant to peoples' lots in life and could be influenced by policy to shape overall well-being. Based on the knowledge from Paper 1, both preference-weighted and unweighted measures of HRQoL were used to identify variations in the association between health and SWB, which is an important contribution of this thesis. Most previous studies focused on the partial effects of health, income, and social relationships, with little empirical analyses on the integrated impacts of these factors on SWB, and they rarely investigated the relative importance of these factors. Moreover, previous studies based their conclusions on average impacts, which ignores the crucial fact that the effect of these predictors may differ across individuals with different levels of SWB. Thus, Paper 2 went beyond the analyses of average impact to examine the relative importance of health, income, and social relationships for SWB, and to test whether the relative importance of these predictors differed at different levels of SWB. This has important policy implications,

particularly when trying to understand whether a certain intervention is equally important for individuals with lower and higher levels of SWB.

Two relatively novel methods were applied to achieve these research objectives. First, for the first time in the field of SWB, the Shapley value regression approach [27] was applied to identify which predictors were more important for SWB. This approach measures the marginal contribution of each predictor in the total explained variation of SWB (by decomposing it as fair shares to individual predictors). Second, the quantile regression model (QRM) was applied to determine the extent to which the relative importance of the predictors vary by level of SWB. This is one of the few studies [28-32] that empirically investigated SWB using this approach.

Obviously, health, income, and social relationships are key components in life satisfaction, but these variables are inter-correlated. Therefore, Paper 3 further examined the direct effect (intrinsic value) and indirect effect (instrumental value) of health, via income and social relationships, on SWB. To our knowledge, no previous empirical research exists on whether income and social relationships simultaneously mediate the link between health and SWB.

It is also worth mentioning that the use of direct and indirect measures of HRQoL, including diagnoses types, enabled us to confirm the consistency of the effects of health on SWB. Moreover, this study used a composite variable “social relationships”, which could also be an asset. It comprised relationships with families and close friends, as well as social isolation and exclusion, which would reflect the broader importance of social life on SWB.

2 Background

2.1 Health-related quality of life

2.1.1 Concepts and definitions

Quality of life (QoL) is a broad concept covering all aspects of human life. Although there is no single definition of QoL, the definition given by the WHO is: "... individuals' perception of their position in life in the context of the culture and value systems in which they live and in relation to their goals, expectations, standards and concerns. It is a broad ranging concept affected in a complex way by the persons' physical health, psychological state, level of independence, social relationships, personal beliefs and their relationship to salient futures of their environment [33]."

When QoL is considered in the context of health and disease, it is referred to as *health related-quality of life* (HRQoL) [34]. This multi-dimensional concept goes beyond direct measures of health to incorporate domains related to physical, mental, emotional, and social functioning and determines the consequences of health status on quality of life [35, 36]. Except for the last two domains listed in the WHO definition (personal beliefs and environment), all other domains are directly related to health and can be narrowly defined as HRQoL [33]. Moreover, in addition to physical health and psychological state, HRQoL includes level of independence (e.g., individual's financial position), and social relationships. Thus, the concept of *health* (as defined by WHO) may differ from the wider notion of HRQoL, which is influenced by people's perceptions, experiences, beliefs, and expectations [37, 38]. HRQoL is a subset of quality of life: QoL comprises all domains that affect an individual's life, while HRQoL incorporates factors related to an individual's health.

2.1.2 The need for measuring health outcomes

HRQoL is a major concern among decision-makers, health care practitioners, and researchers in most developed countries [39]; thus, many stake-holders now recognise the importance of measuring it. An ideal health outcome measure should reflect a population's dynamic state of physical, mental, and social well-being [40]. Generally, the major rationale or motivation behind HRQoL measures is to assess the relative merits of alternative health programmes in the context of increasing pressure on health care resources, and to assess the impact of clinical outcomes [41-43]. Although the application of HRQoL measures to different conditions and

populations has increased in recent years, its assessment has become more sophisticated, and it is methodologically more rigorous [37, 44]. A number of factors should be considered when assessing the quality of HRQoL measures, such as reliability, validity, precision (to distinguish health and illness), responsiveness (to detect clinically important changes), acceptability, and feasibility (i.e., in terms of time and cost) [45], but there is still no general consensus on which HRQoL measure should be used as the gold standard. Indeed, the quality of different HRQoL measures may differ depending on what is measured and how it is measured.

2.1.3 The structure of health-related quality of life measures

Several HRQoL measures are now available [46], and most of them are disease-specific instruments. HRQoL measures can be broadly divided into generic vs. disease-specific measures. Generic instruments provide: a summary of HRQoL measure that can be applied to all diseases, while disease-specific instruments render disease-specific measures and focus on problems associated with specific diseases or patient groups [43, 47]. Disease-specific instruments may enhance measurement sensitivity, while a generic instruments enable comparisons across different population groups [41, 43], ranges of interventions, and diagnostic conditions, which is particularly important for decision-makers who are trying to set priorities and allocate resources. Generic instruments can further be divided into preference-based and non-preference-based instruments. The former is particularly designed for the calculation of quality-adjusted life years (QALYs), which are used in health economic evaluations. The application of non-preference-based instruments (e.g., SF-36) was common in clinical trials and other health studies, but limited in economic evaluations [43].

Selection of an instrument depends on the research objectives, the characteristics of patients, and the application of resultant measures in policy analysis [48]. Since the purpose of HRQoL measures is to determine the impact of disease on general function, O'Connor [42] argued that in some settings, generic measures can be as responsive as disease-specific measures, and that generic measures are sometimes even better as they can capture a wide variety of dysfunction that is not specific to the disease. This thesis focuses on generic preference-based HRQoL measures.

2.1.4 Generic preference-based measures

In economic evaluations, a common currency is applied, which incorporates the impact of ill health (quality of life) on a multi-dimensional scale and survival (length of life) in the form of QALYs. This standardisation is usually done by assigning different utilities (or preference-weightings) to different health states [49]. This procedure facilitates comparisons between interventions and across diseases, which is important for priority setting and consistency in decision-making.

Generic preference-based measures involve preference-weighting, by which health state values are estimated through preference elicitation and complex algorithms. Such preference-based measures are commonly referred to as multi-attribute utility (MAU) or HSU instruments. An MAU represents the idea of a *multi-attribute* health state classification system, based on the concept that health state can be defined in terms of a number of attributes [50]. The basic idea behind HSU instruments is that *utilities* are obtained by assigning *cardinal values* to each *health state*, on a scale from 0.00 (being dead) to 1.00 (being healthy) [51]. Negative values can be allowed for some health states that may be regarded as worse than being dead. Here, the term *utility* implies the desirability or strength of preferences that individuals exhibit for a given health state instead of the usefulness of the health state in which the individual is found [50]. Hereafter, HSU will be used when referring to generic preference-based measures.

So far, six HSU instruments have been identified in the literature: the EQ-5D, the short-form six dimensional questionnaire (SF-6D), the health utility index mark 2/3 (HUI2/HUI3), the 15-D, the self-assessed quality of well-being scale (QWB-SA), and the assessment of quality of life (AQoL) questionnaire [52]. They differ in how many items – or health dimensions – they include; how the items are described; how many levels each dimension can take; and how the described health statuses are valued [43, 53] (see Table 1). Not surprisingly, there is disagreement in the literature on which HSU instrument is the best. The EQ-5D is by far the most widely applied instrument (77% of all cost-utility analyses published in 2010) followed by the SF-6D (12% of published studies) [54].

Table 1. HSU instruments descriptive systems

Instruments	Country of origin	Dimensions	Items ^c	Response levels	Health states defined	Relative use ^d (%)
EQ-5D-5L/3L	UK	5	5	5/3	3,125/243	63.2
SF-6D	UK/USA	6	11	4 to 6	18,000	8.8
HUI2	Canada	7	7	3 to 5	24,000	4.6
HUI3	Canada	8	8	5 to 6	972,000	9.8
15D	Finland	15	15	5	31 billion	6.9
QWB-SA ^a	USA	4	71	2 to 3	945	2.4
AQoL ^b	Australia	8	35	4 to 6	2.37*10 ²³	4.3

^a The three multi-response items of the QWB-SA - mobility, social activity, and physical activity - define 47 health states, and the remaining symptom/problem groups define 898 health states. The last column includes studies by the original version of Quality of Well-being (QWB) instrument as well.

^b AQoL has 35 items, from which eight dimensions are constructed, and hence is labelled as AQoL-8D.

^c 'Item' refers to a question with a series of possible response levels.

^d The relative use of HSU instruments was based on 1682 studies identified between 2005 and 2010, among which only 15% were primarily concerned with economic evaluations (for details, see Richardson *et al.* [52]).

Note that *health state* refers to the description of individual health status with the help of a given HRQoL measure. This concept can be explained using the EQ-5D because it is the most widely used instrument, and all three papers included in this thesis used this instrument. The description of other HSU instruments used in this thesis are reported in the Appendix. The EQ-5D describes health in terms of five dimensions (see Box 1). The original version of the EQ-5D allowed respondents to indicate the degree of impairment on each dimension according to three response levels (no problems, some problems, and extreme problems). This health classification system was referred to as EQ-5D-3L and defined 243 (or 3³) health states. In the new version of the EQ-5D, the original dimensional structure was retained, but the descriptive system now includes five levels of severity. This new health classification system, EQ-5D-5L, defines a total of 3,125 (or 5⁵) health states, where no problem on each dimension (11111) describes full health, and extreme problems on each dimension (55555) corresponds to the worst possible health state (or the 'pits'). The larger the number of dimensions and/or response levels, the higher the number of health states that can be defined (see 15D and AQoL in Table 1 for an example).

Box 1: EQ-5D-5L classification system

Select the answer under each heading below, that best describes your own health state *today*

a) Mobility

- I have no problem in walking about
- I have slight problems in walking about
- I have moderate problems in walking about
- I have severe problems in walking about
- I am unable to walk about

b) Self-care

- I have no problems washing or dressing myself
- I have slight problems washing or dressing myself
- I have moderate problems washing or dressing myself
- I have severe problems washing or dressing myself
- I am unable to wash or dress myself.

c) Usual Activities (e.g. work, study, housework, family or leisure activities)

- I have no problems doing my usual activities.
- I have slight problems doing my usual activities.
- I have moderate problems doing my usual activities.
- I have severe problems doing my usual activities.
- I am unable to do my usual activities.

d) Pain/Discomfort

- I have no pain or discomfort.
- I have slight pain or discomfort.
- I have moderate pain or discomfort.
- I have severe pain or discomfort.
- I have extreme pain or discomfort.

e) Anxiety/Depression

- I am not anxious or depressed.
- I am slightly anxious or depressed.
- I am moderately anxious or depressed.
- I am severely anxious or depressed.
- I am extremely anxious or depressed.

In general, HSU instruments allow subjects to describe the impact of ill health and assign a utility score to those descriptions based on an individual's preferred health state [55].

Measurements from HSU instruments are generally constructed in two stages: the description of health states in terms of domains or dimensions, followed by the valuation of these health states. In the first step, a standardised *descriptive system* for health or its impact on HRQoL must be developed, composed of a number of dimensions/attributes that together describe a combination of health states. For instance, the EQ-5D-5L classification system contains five dimensions, and each dimension includes five severity levels. Then an *algorithm* is applied to determine the numerical value to be attached to the health states identified by the

classification system. These algorithms have been based on various valuation methods. Those most commonly used for valuing health states are the visual analogue scale (VAS), standard gamble (SG), time trade-off (TTO), and more recently, the discrete-choice experiments (DCE) method (see Table 2).

The visual analogue scale

The VAS is a kind of ‘feeling’ thermometer, usually illustrated vertically, with well-defined end-points. It has a bottom value of 0, referred to as worst imaginable health (or dead), and goes to a top of 100, referred to as best imaginable or full health [43, 56, 57] (see Appendix 1). Respondents are generally asked to rank specific health outcomes on the VAS from most to least preferred and then to place the outcomes on the scale so that the intervals between each outcome correspond to differences in the individual’s preferences for each outcome [41]. The VAS is intended to have interval properties, whereby the difference between 20 and 40 should equal the difference between 60 and 80.

Standard gamble

Unlike the VAS, standard gamble (SG) includes choices involving risk and uncertainty in the assessment of health outcomes and, hence, provides a truer representation of preferences [41]. The SG presents the respondent a choice between being in a described health state for a given period of time, t -years with certainty, and a risky option with one better and one worse outcome (usually full health and death). Assume a general case where an intermediate health state (HS_i) is preferred to a temporary health state (HS_j). In the SG, the subject is offered two alternatives. Alternative 1 is the *risky option* with two possible outcomes: either the patient is returned to full health with probability p , or the patient lives for the time period t in the worst HS_j followed by full health with probability $1 - p$. Alternative 2 represents the *certain* outcome of HS_i for an equivalent amount of time (t years) after which the patient is returned to full health. Then, probability p varies until the respondent is indifferent between the two alternatives; that is,

$$\text{Alternative 1} = \text{Alternative 2} \Rightarrow p * (\text{full-health}) + (1-p) * HS_j = HS_i$$

The right-hand side is the value of being in HS_i , and the left-hand side is the expected value of choosing the risky option. Hence, if full health = 1, the required utility for state HS_i for time t is equal to $p + (1-p) * HS_j$. If HS_j is replaced with death (i.e., for chronic conditions that are

preferred to being dead), the value of HS_i equals zero and the required preference score for state HS_i is simply p (for details, see Torrance [51]).

Table 2. Valuation methods of HSU instruments

Instrument	Valuation method	Forms of algorithm	Scoring formula	Minimum score
EQ-5D ^a	TTO, DCE,	Statistical	Additive	3L: -0.594 5L: -0.281
SF-6D	SG	Statistical	Additive	0.301
HUI3	SG, VAS	MAU ^b	Multiplicative	-0.36
15-D	VAS	MAU	Additive	0.00
QWB-SA	VAS	MAU	Additive	0.00
AQOL-8D ^c	TTO	Statistical and MAU	Multiplicative	-0.04

^a The minimum score for the UK tariff has been reported (other countries' tariffs also exist).

^b The MAU theory reduces the valuation task by making simplifying assumptions about the relationship between dimensions (for details, see Brazier *et al.* [43]).

^c AQoL-8D employs both MAU theory and statistical modelling to estimate a function for valuing health states. It also combines multiplicative and exponential scoring formula to compute utility index.

Time trade-off

Time trade-off (TTO) was developed in response to the more complex techniques in SG [58]. TTO presents the respondent with a choice between two 'certain' events that involve a 'trade-off' between quality and quantity of life [41]. TTO offers a choice between a longer life in an inferior health state and a shorter life in better health state. Usually, respondents are asked to imagine themselves in the described health state for a period of t years (e.g., $t = 10$), and then asked how many years they would be prepared to trade-off in exchange for full health. For instance, for a chronic state considered better than being dead, the first alternative involves living in poor health state, say HS_i , for time t , and the second alternative is living in full health for time x , where $x < t$. Then time x is varied until the respondent is indifferent between the two choices: $t*HS_i = x*(full\ health)$. This results in the score for state HS_i equal to x/t , assuming 'full health' = 1. Further explanation, including the analyses for intermediate health states considered better than the temporary state, and a chronic state worse than being dead were detailed in Drummond *et al.* [41] and Brazier *et al.* [57].

The major challenge with the analyses for conditions that are worse than being dead is that it does not impose a lower limit on states that are not preferable to death, leading to a scale ranging from minus infinity to 1 [51, 59]. Dolan [60] recommended a value of -1 for the worst possible state, but this was an arbitrary value with no theoretical support [61]. Thus, Robinson and Spencer [59] proposed a new procedure, capable of valuing health states that are deemed worse than being dead as a solution to arbitrary transformation in the conventional TTO, referred to as lead-time and lag-time TTO.

The lead-time and lag-time TTO approaches involve adding additional time in full health to both the time available for trading and to the scenario comprising the health state being valued [62]. When additional time in full health precedes the health state being valued, it is referred to as lead-time TTO [62, 63], whereas lag-time TTO is when additional time in full health is placed after the health state being valued [64]. Similar to conventional TTO, lead-time TTO offers respondents a choice between two ‘certain’ events: *alternative 1*, full health for y years followed by HS_i for $t-y$ years; and *alternative 2*, full health for z -years, where $z > y$ for states considered better than being dead and $z < y$ for states considered worse than being dead (see Brazier *et al.* [43] for detail). Then, z is varied until the respondent is indifferent between the two alternatives, at which the utility for state HS_i becomes: $(z-y)/(t-y)$. This value is positive for states that are better than being dead and negative for states that are worse than being dead [62]. Lag-time TTO follows a similar procedure, except that the additional time in full health (y) follows, rather than precedes, the time spent in HS_i . Studies reveal that there is no systematic differences between the health state values obtained using the lead-time and lag-time TTO [63]. However, time preferences regarding health at the end of life may lead to a difference in values owing to differences in the placement of the time spent in state HS_i relative to being dead [65].

Research conducted using lead-time TTO showed severe framing effects and clearly demonstrated that respondents had difficulties with the task [59, 63, 66]. Consequently, a composite TTO was proposed as a compromise between the conventional TTO and lead-time TTO [67], which combines the conventional TTO for health states considered better than being dead and the lead-time TTO for states below zero. Recently, EuroQol introduced this approach as a valuation technique for the EQ-5D-5L classification system. In short, the TTO

reflects an explicit QALY choice, in that it makes a trade-off between quantity and quality of life.

The Discrete Choice Experiment

There is concern that the tasks involved in the TTO and SG are too cognitively demanding for certain populations, leading to several inconsistencies and subsequent exclusions that limit the representativeness of resultant values [68, 69]. In the discrete choice experiment (DCE) method, respondents are provided with two or more profiles from which they choose the most or least preferred. Each profile is constructed based on a descriptive system made up of levels of a limited number of important attributes (for details, see Brazier *et al.* [43] and Bansback *et al.* [70]). Such DCE tasks can be repeated for each respondent in order to infer the utility weight that should be attached to each level for each dimension. Usually, the conditional logit model and its variants can provide information on the relative preferences of one health state over another [71] based on the random utility theory [72]. The utility scale for DCE data from this model is not anchored to the 0 to 1 scale suitable for QALY calculations, but researchers have successfully introduced various methods to resolve this challenge. Some introduced a ‘TTO-like’ format called *DCE_{TTO}* by linking health states to normal health and death within a DCE by including ‘survival duration’ as an attribute [70, 73]. Others include *risk* of immediate death as an option, sometimes referred to as *modified SG*, in order to link utility values directly to death in the DCE method [74].

Comparing valuation techniques

The different valuation techniques described above produce different outcomes, resulting in different QALY measurements. One basic difference between SG and TTO is that the SG is framed in terms of risk, and TTO is considered to be riskless. Further, utility values produced by SG are generally greater than those of TTO, though not by much. Some of the major arguments for the upward biases in SG utility estimates were the effect of utility curvature, probability weighting, loss aversion, and scale compatibility [75]. SG imposes no restrictions on the utility function of the duration of the health state, and hence, utility curvature does not lead to a bias in the SG utilities. However, utility curvature does bias TTO values downward, which assumes that utility is linear in duration [43]. Obviously, probability weighting and the risk-averse behaviour of many respondents when death becomes a consideration in the SG may lead to an upward bias in utilities [43, 75].

While there is no sacrifice involved in giving a low value when using VAS, there is sacrifice involved with SG and TTO, either in terms of taking a risk of death (SG) or giving up length of life (TTO), which would restrict one's tendency to state a low implied value in TTO and SG compared to VAS. Clearly, VAS is relatively simple and easy to complete, which makes it less expensive to administer than TTO, SG, or DCE. However, the choice-less nature of the VAS method may not necessarily produce values that reflect preferences on an interval scale [76]. Among the choice-based methods, the SG and TTO appear to involve more time and a high level of respondent burden to obtain estimates. In contrast, DCE tasks are generally considered simple to complete, and they are often evaluated with a self-completion format or computer programme, unlike the conventional cardinal utility measures (TTO and SG) [70].

In general, there is no gold standard approach that can be applied in valuing health states. Different methods produce different preference values, and hence the outcome of an economic evaluation will depend on the method used. This is undesirable and continues to be a challenge.

2.2 Subjective well-being

2.2.1 Definition and concepts

Research on SWB is progressing deeper into the mainstream of various academic disciplines and increasingly drawing the attention of policy-makers. Ed Diener [77] described SWB as having a good mental state, including all of the various cognitive evaluations that people make of their lives, and the affective reactions of people to their experiences. Thus, SWB encompasses life satisfaction, positive affect, and negative affect. Life satisfaction involves an *evaluative judgment* of how one's life is faring, which requires making an effort and remembering past experiences, whilst positive and negative affect involve measuring the *hedonic experiences* people have either in real time, or shortly after these experiences have occurred [3, 77]. The consensus on affect is that the absence of negative moods and emotions needs to be assessed separately from the presence of positive ones. SWB thus measures not just feeling happy, but also not feeling sad or angry, and being satisfied with one's life overall. This concept of SWB has been rooted in the interpretation of Jeremy Bentham's term of "utility," which later widened the meaning of pleasure to include "benefits, advantages, profits, good or happiness...[and the absence of] failure, suffering, misfortune or

unhappiness” (p. 322) [78]. The utilitarian concept of happiness thus encompasses both the presence of pleasure and absence of pain.

In addition to ‘hedonic’ or emotional experiences, SWB also includes functioning well, such as having a sense of engagement and competence, being resilient during setbacks, having good relationships with others, and a sense of belonging and contributing to a community [23]. Thus, SWB is an umbrella term that comprises the various ways in which people evaluate their lives, including life satisfaction, pleasant emotions, satisfaction with domains such as work and health, feelings of fulfilment and meaning, and low levels of unpleasant emotions [79]. Generally, SWB is measured by simply asking people about their life. In this sense, it shares the democratic aspect of preference satisfaction, in that it allows people to decide how good their life is, without the judgment of *experts* or someone else deciding their well-being [80], and comprises satisfaction (both in general and satisfaction with specific domains), as well as positive and negative affects.

2.2.2 Measuring subjective well-being

The measurement of SWB has a long history, going back to the writings of Bentham [81] and [82]. They argued that happiness is the greatest good, hence the aim of policy-makers should be to create the greatest happiness for the greatest number of people. Nevertheless, no attempts have been made to measure SWB until recently. Today, there is growing interest in the measurement and use of SWB for research and policy purposes. The literature has classified three different ways in which SWB can be measured [6, 83]: as a life evaluation, experienced well-being, and ‘eudemonic’ well-being.

SWB is measured as a life evaluation when people are asked to provide global assessments about their life. This measure has been used most often in policy and/or research because of its prevalence in several surveys, as well as its comprehensibility and appeal to policy-makers [84]. Life evaluation may be measured either through a *global satisfaction* measure, in which people evaluate their lives as a whole using a single question, or through a set of multiple items, in which people state their degree of satisfaction with different aspects of their lives. A typical example of the former is: “*All things considered, how satisfied are you with your life as a whole these days?*” or “*Taken all together, would you say that you are very happy, pretty happy, or not too happy?*” [85]. Recent surveys, however, have included multiple

questions eliciting evaluative well-being. The most widely used is the Satisfaction with Life Scale (SWLS), which measures life satisfaction by asking respondents to report their level of agreement with five statements on a seven-point Likert scale from strongly disagree to strongly agree [86, 87] (see Box 2). Although the single-item global life satisfaction question is simple and requires less response time than multi-item measures, the latter appears to be more reliable. For instance, the multi-item life satisfaction has an estimated reliability of close to 0.80 compared with single-item global life satisfaction measures, which have an estimated reliability of about 0.60 [85, 88].

Experienced well-being is very closely associated with mental state, which depends entirely upon feelings held by the individual during a given period of time [6]. It is reflected by an individual's report of mood, affect, or emotion and corresponds to the Benthamite, utilitarian view of well-being as pleasure and pain [89]. Thus, experienced well-being can be thought of as the average balance of pleasure over pain, measured over the relevant time period [7]. The Experience Sampling Method [90] and the Day Reconstruction Method [91] are examples of experienced well-being measurements. However, these methods are very costly, involve a high burden on respondents, and are difficult to implement [83]. Thus, several surveys applied the following simple questions as *experience* measures: “Overall, how happy did you feel yesterday?” and “Overall, how anxious did you feel yesterday?” The former is intended to measure positive affect, whilst the latter measures negative affect. Both are measured on 0 to 10 scale, where 0 is ‘not at all’ and 10 is ‘completely’ (See Dolan and Metcalfe [6]).

‘Eudemonic’ well-being involves issues related to psychological needs, such as autonomy, environmental mastery, personal growth, positive relationships, purpose in life, and self-acceptance [92]. These accounts draw from Aristotle’s ‘eudemonia’, which states that all fully rational people strive to have the best life possible, creating a bridge between the more private realm of personal happiness to the more public issues of competence, freedom and opportunity [93]. These ideas have been well elaborated in the seminal work of Amartya Sen [94], which highlights the importance of having the opportunity to develop capabilities and to function effectively if we are to *flourish* as human beings. Despite difficulties to construct comprehensive questions related to purpose and meaning in life, some studies have suggested questions about *worthwhileness* as a proxy to measure eudemonic well-being [6, 7], such as

“Overall, to what extent do you feel that the things you do in your life are worthwhile?”

Responses are given on an 11-point scale, where 0 is ‘not at all’ and 10 is ‘completely’.

In summary, evaluative questions are the most frequently used survey items within the field of SWB [95], which is generally measured using self-reported methods. This thesis applied life evaluation, where multiple questions were used to evaluate well-being.

2.2.3 Determinants of subjective well-being

Health, income, and social networks, as well as socio-demographic characteristics are the major determinants of SWB, though other potential determinants have been identified [13, 23]. Personal characteristics (e.g. genetic factors and personality traits) are also important determinants of SWB [96], but such variables cannot be easily influenced by policy.

Health

Several studies have consistently revealed a strong relationship between health and SWB. Psychological health is more strongly correlated with SWB than physical health due to the close correspondence between SWB and psychological health [9]. Although over time people adapt to their health or disability, this adaptation is usually far from complete. In fact, using the fixed-effects model (that controls for unobserved individual heterogeneity overtime), Oswald and Powdthavee [97] found that disability reduces life satisfaction (on a 1-7 scale) by 0.596 points for those with past disability, by 0.521 points after 1 year of disability, 0.447 points after 2 years, and 0.372 after 3 years. Like SWB, HRQoL measures are inherently subjective and pertain to an individual’s self-assessment of multiple health dimensions. Studies have shown that self-rated health is more strongly related to SWB than health ratings assigned by others, such as physicians or relatives [98]. Further, HSU instruments with limited coverage of emotional health are less effective in predicting SWB [99]. Similarly, objective health (usually measured as the presence of illness) and disability are more weakly associated with SWB than self-rated health [88, 97]. Irrespective of how HRQoL is measured, health has strong, significant associations with SWB.

Income

Much research has been undertaken on the relationship between income and SWB, particularly so after a seminal paper by Easterlin [100]. He suggested that, at least within individual developed countries, people with higher incomes are happier on average, whereas

an international comparison showed no difference in the average level of self-reported happiness by per capita income. This is commonly known as the Easterlin Paradox. However, several studies have shown a robust positive relationship between income and SWB across countries and over time [9, 101, 102]. For instance, Stevenson and Wolfers [102] studied the relationship between income and SWB using time-series data, and their findings suggested that increases in absolute income are related to both increased individual and national SWB. Some researchers have argued for a modified version of Easterlin's hypothesis that would acknowledge the existence of a link between income and well-being among those whose basic needs have not been met, but the same researchers claim that beyond a certain threshold, income is unrelated to SWB [4].

Despite the debate on the relationship between income and SWB, there are several key findings that consistently appear in the literature. Most evidence revealed a positive relationship between income and SWB, but with diminishing return to income both at the national and the individual level. For instance, most cross-country studies found a significant, positive correlation between per capita income and SWB [13, 103, 104], implying that higher-income countries experience higher SWB. Similarly, several national studies demonstrated a positive association between individual income and SWB [9, 105, 106]. It has also been argued that richer individuals express higher SWB than poorer individuals. However, additional income makes poor individuals happier than rich ones [107], indicating diminishing returns to SWB with respect to income.

Most national cross-sectional studies have shown that individuals with higher incomes have higher SWB, though the degree of the association depends typically on the age of the individuals. Some studies have suggested that the youngest and oldest age groups are less influenced by income than their middle-aged counterparts [108]. The correlation between income and SWB varies across countries as well, being higher in developing than in developed countries [109], though cultural and political setup might explain such variations. Similarly, duration of unemployment [110] and the degree and availability of an unemployment welfare system [111] influences the income-SWB relationship. Studies have shown that relative income is an important predictor of SWB as compared to absolute income [15], which implies that an increase in income may have little effect on SWB if the change in

income is the same across the relevant comparison groups. Furthermore, aspirations and expectations, which is driven by past income [13], are important determinants of SWB.

Education

The association between education and SWB is often mixed, with several studies reporting a weak positive relationship [112, 113], while others found an inverse association [114], and still others suggested no significant relationship between education and SWB [115, 116]. The effect of education on SWB often depends on the presence of other correlate variables, such as income and health. For instance, the role of education can be merely instrumental if it serves to increase income, and hence its effect drops after models are controlled for income and other indicators of socioeconomic status [117]. These mixed findings on the relationship between education and SWB could be attributable to differences in the control variables included in the model [118] and the methodological approaches applied.

Unemployment

Many studies have shown a strong adverse effect of unemployment on SWB [119, 120]. Obviously, being unemployed involves many costs other than just financial loss. For example, the loss of social networks, losing a source of self-esteem, the loss of a career to develop and to which to apply one's skills, etc., can lead to unhappiness [121]. The impact of unemployment on SWB varies by gender, age, education, and religious beliefs. Unemployment usually involves more burden for men than women [122], and for middle-aged individuals than younger or older age groups [114]. It has also been argued that the burden of unemployment is greater among those with higher education [114], and lower among those with strong religious beliefs [123].

Social relationships (including marital status)

Recent developments in the study of SWB have considered 'social capital' as a potential explanatory factor. Social capital describes measures of individual or group networks, general trust, civic involvement, and personal connections [11, 124, 125]. Though this definition is quite broad, the quantity and quality of intimate relationships and social bonds among individuals are the most important components of social capital and are strongly correlated with SWB [126-128]. Empirical evidence has revealed that support from family, friends, and the wider community is strongly related to higher SWB [129, 130]. The literature has also

shown that objective, measureable aspects of an individual's relationships and social network influence SWB, but only modestly as compared to subjective social indicators. For instance, Cummins *et al.* [131] argued that objective social indicators such as social support and number of friends fails to measure how people feel about their lives and are poor indicators of SWB. This effect appears to be larger for subjective measures, which is not surprising as they correspond closely with SWB. The number and strength of social connections are among the largest and most robust predictors of SWB (e.g., Dolan *et al.* [13]; Helliwell [128]; Helliwell and Putnam [11]). Studies have consistently revealed that active participation in social activities, community involvement, volunteering, and providing help to others are all associated with high levels of SWB [11, 132].

Being married is associated with higher SWB compared with those who never married, or are widowed, separated, or divorced [116, 121]. They also reported that being separated is associated with the lowest level of SWB, even lower than being divorced or widowed (as the series of difficulties and challenges during separation gradually decreases due to the coping mechanism). Further, in a study by Lucas *et al.* [133], the death of a spouse leads to a substantial drop in SWB, which never returned to its initial level. Thus, change in marital status is an important determinant of SWB.

Personal characteristics

There is extensive literature on the link between SWB and personal characteristics such as age, gender, ethnicity, genetics, personality traits, and personal values. Studies consistently suggested a U-shaped SWB with age, with the highest level of satisfaction observed in younger and older age groups and the lowest life satisfaction in middle age [13, 134].

Although there is no consensus in the literature on the nature of differences in SWB by gender, women usually report higher SWB than men [121, 135]. However, some studies have shown higher levels of SWB for men [136], and others found no evidence of gender effects [137], particularly when specific subjects were considered, such as those who cannot work due to ill health [97] and those who provide informal care for others [138]. This variation could be attributable to differences in control variables and methodological approaches.

Ethnicity is an important predictor of SWB, for example evidence from the US suggested that Whites have higher SWB than African Americans [118]. A study by Dorsett *et al.* [139] found that ethnic Africans generally report lower SWB than native Whites and Asians in the UK. More recently, a study by Knies *et al.* [140] also showed that people from minority ethnic groups have lower life satisfaction than those from the White majority in the UK. Several psychological studies have investigated the relationship between personality traits and SWB (for a detailed review, see DeNeve and Cooper [21]), and the findings suggest that this factor is one of the strongest and most consistent for predicting SWB. In the economics literature, personality traits (usually known as individual heterogeneity) are assumed to be constant and are handled by employing econometric approaches such as the fixed-effects model. In line with this, Boyce [141] has shown that personality traits are one of the main components of individual heterogeneity and can be used to increase the understanding of individual variations. Genetic factors also affect SWB; studies on identical twins found that genetic factors explained a large proportion of the variance in SWB [19, 21, 142]. Materialistic values related to personal characteristics also negatively affect SWB. Individuals who hold more materialistic values are less satisfied with their life than less materialistic individuals [143, 144].

In general, SWB is responsive to changes in policy-relevant factors such as income, education, health, social relationships, employment conditions, etc., as well as genetic factors and personality traits, which are less likely influenced by policy. As income is more important for the poor than for affluent individuals, policy directions aimed at generating income streams for the poor may improve SWB in this subgroup. Further, to minimise the negative effect of relative income or social comparison on SWB, reducing socioeconomic disparity is crucial. Thus, well-designed policies aimed at reducing poverty and social and economic inequality are important in maintaining SWB. Public policies that keep people healthy and educated as well as promote social networks, including family relations, should be encouraged. Public policies aimed at job creation are also useful. These policies not only generate income; they also lead to many positive side-effects that are important for SWB, such as feelings of fulfilment, relationships with colleagues, knowledge sharing, and feeling secure [121, 145].

3 Objectives

This thesis aims to i) explore the importance of preference-weighting in HSU instruments; and ii) examine the contribution of policy-relevant factors to SWB. The analyses herein are based on an international sample of individuals aged 18 and above, and this thesis comprises three papers. Paper 1 examined the relative importance of preference-weighting in two contrasting instruments: the shortest, but most widely-used instrument, the EQ-5D, and the more comprehensive 15D. Based on the findings of Paper 1, the effect of both weighted and unweighted HRQoL measures on SWB were investigated in two follow-up papers. Paper 2 looked into the relative importance of health, income, and social relationships for SWB; Paper 3 continued to examine the link between health and SWB, and the mediating role that income and social relationships play in this link. More specifically, the research questions addressed were:

Paper 1

- What difference does it make when preference-weighted values are assigned to health states, as compared to unweighted values obtained by linearly transforming summary scores on a 0 to 1 scale?
- How much of the observed discrepancy is due to scale length differences, and how much is attributable to the importance weighting of health dimensions?

Paper 2

- What is the relative importance of health, income, and social relationships for SWB?
- Does the (relative) importance of each predictor differ by level of SWB distributions?

Paper 3

- Do income and social relationships mediate the association between health and SWB? i.e., disentangling the indirect effect of health (via income and social relationships) from its direct effect on SWB.

4 Materials and methods

4.1 Description of the data

This thesis is based on data from the Multi Instrument Comparison (MIC) project undertaken in 2011/12. The MIC project is the largest study undertaken worldwide that aims to compare a wide range of instruments purporting to measure HRQoL and SWB. Data was collected by a global company, CINT Pty Ltd., which administered an online survey to respondents from six OECD (Organization for Economic Cooperation and Development) countries: Australia, Canada, Germany, Norway, the UK, and the US. Respondents included a representative cohort of undiagnosed individuals (the healthy group), and individuals with one or more of seven chronic conditions (asthma, arthritis, cancer, depression, diabetes, hearing loss, and heart disease, referred to as disease groups) using quotas based on age, gender, and education. In order to be included in the healthy group, respondents had to have no chronic conditions and a VAS score of at least 70 (where 0.00 represents *being dead* and 100 the *best possible health* in terms of physical, mental, and social functioning).

Table 3. Number of respondents by disease and country

Respondents	Country						Total
	Australia	Canada	Germany	Norway	UK	USA	
<i>Healthy group</i>	265	328	260	288	298	321	1760
<i>Disease groups</i>							
Arthritis	163	139	159	130	159	179	929
Asthma	141	138	147	130	150	150	856
Cancer	154	138	115	80	137	148	772
Depression	146	145	160	140	158	168	917
Diabetes	168	144	140	143	161	168	924
Hearing problems	155	144	136	115	126	156	832
Heart diseases	149	154	152	151	167	170	943
Subtotal	1076	1002	1009	889	1058	1139	6173
Total	1341	1330	1269	1177	1356	1460	7933

To ensure the quality of data, respondents were excluded when completion time was below 20 minutes, which was judged to be the minimum time in which the survey questions could be

adequately answered. Respondents with inconsistent responses on similar questions were also excluded. In total, about 17% of respondents were excluded. Detailed selection procedures have been reported elsewhere [146]. After exclusions, the total number of subjects in the healthy group and the seven disease groups was 7933. The healthy group was generally younger than the disease groups, while gender and education distributions were similar.

Papers 1 and 2 employed the full sample of 7933 respondents, whereas Paper 3 considered only respondents with chronic conditions (N = 6173). A summary of countries and disease groups included in this thesis is presented in Table 3.

4.2 Measures of variables

The MIC project included several questions on HRQoL and SWB, as well as on major socio-demographic variables. Each of the three papers included in this thesis carefully selected relevant variables to address the respective research objectives.

In Paper 1, EQ-5D-5L and the 15D were the main variables of interest. The EQ-5D-5L classification system defines 3125 (or 5⁵) health states (Table 1 and Box 1). We used the English ‘tariff’, which is anchored on a -0.281 to 1.00 scale. The tariff was derived from the stated preference of 996 members of the English general public using a hybrid model (a combination of composite TTO and DCE tasks) as a direct elicitation of its value sets [147]. The unweighted EQ-5D-5L was obtained by taking simple summary scores on a 0.00 to 1.00 scale and assigning equal importance weights to each dimension. This was then linearly transformed onto the same scale as the preference-weighted scale to make meaningful comparisons with its unweighted counterpart.

The 15D defines over 30 billion health states [148]. Its dimensions include mobility, vision, hearing, breathing, sleeping, eating, speech, elimination, usual activities, mental function, discomfort and symptoms, depression, distress, vitality, and sexual activity (Appendix 2. Its weight was developed based on the Finnish general public. Its preference-weights were given on a 0 to 1 scale, where 0 and 1 represented ‘dead’ and ‘no problems on any dimension’, respectively. The weights were obtained using VAS and then combined using an additive model [149]. There is no health state worse than being dead in the 15D. Thus, the unweighted values required no further transformation (as they coincided with the preference-weighted scale).

Four other variables were also considered for comparison of preference-weighted and unweighted values in terms of convergent and known-group validities: VAS score and current standard of living variables (from the full sample), Diabetes-39 (D-39) and the Kessler psychological distress scale (K10). The D-39 is a disease-specific instrument for diabetes patients that contains 39 items, each with a 7-level response scale ranging from 1 (not affected at all) to 7 (extremely affected), and covers five dimensions: energy and mobility, diabetes control, anxiety and worry, social burden, and sexual functioning [150]. The D-39 and K-10 (Appendix 3) were chosen because both are closely related to one or more dimensions of the EQ-5D-5L and the 15D.

Papers 2 and 3 employed similar variables: SWB, HRQoL, income, and social relationships. In addition, major socio-demographic variables (age, gender, marital status, education, and unemployment), as well as country and disease variables were applied.

Subjective well-being

SWB was measured by a multiple-item SWLS, which consisted of five items ranked on a seven-point Likert scale ranging from 1 (strongly disagree) to 7 (strongly agree) (see Box 2) [87]. The last two items in the SWLS are closely linked with the age of the respondents. Younger respondents may not (strongly) agree with the last two items no matter how happy they are, because they still have a long life ahead of them with diverse opportunities and challenges. Thus, in accordance with other studies [151, 152], only the first three items were used as a SWB measure. The scale reliability coefficient was 0.935, indicating good internal consistency. This coefficient would have decreased to 0.924 had the last two items been included, supporting their removal. In Paper 2, the total sum of scores from the first three items was normalised onto a 0.00 to 1.00 scale and was used as an outcome variable. In Paper 3, SWB was assumed as a latent construct estimated from the first three items of the observed SWLS indicators using confirmatory factor analysis, which is a measurement model that estimates continuous latent variables based on observed indicator variables.

Box 2: Description of SWLS

	Strongly disagree	Disagree	Slightly disagree	Neither agree nor disagree	Slightly agree	Agree	Strongly agree
a) In most ways my life is close to my ideal	<input type="checkbox"/>	<input type="checkbox"/>	<input type="checkbox"/>	<input type="checkbox"/>	<input type="checkbox"/>	<input type="checkbox"/>	<input type="checkbox"/>
b) The conditions of my life are excellent	<input type="checkbox"/>	<input type="checkbox"/>	<input type="checkbox"/>	<input type="checkbox"/>	<input type="checkbox"/>	<input type="checkbox"/>	<input type="checkbox"/>
c) I am satisfied with my life	<input type="checkbox"/>	<input type="checkbox"/>	<input type="checkbox"/>	<input type="checkbox"/>	<input type="checkbox"/>	<input type="checkbox"/>	<input type="checkbox"/>
d) So far I have gotten the important things I want in life	<input type="checkbox"/>	<input type="checkbox"/>	<input type="checkbox"/>	<input type="checkbox"/>	<input type="checkbox"/>	<input type="checkbox"/>	<input type="checkbox"/>
e) If I could live my life over, I would change almost nothing	<input type="checkbox"/>	<input type="checkbox"/>	<input type="checkbox"/>	<input type="checkbox"/>	<input type="checkbox"/>	<input type="checkbox"/>	<input type="checkbox"/>

Health-related quality of life

Five alternative HRQoL measures were considered in Paper 2: four from generic HSU instruments (EQ-5D-5L, SF-6D, HUI3, and 15D) and one direct measure of health (the VAS). The EQ-5D-5L and 15D were explained above, and the SF-6D, HUI3, and VAS are briefly explained here.

The SF-6D has six dimensions (physical functioning, social functioning, role limitations, pain, mental health, and vitality), each with four to six levels, and defines 18,000 health states [153]. An econometric model with SG scaling was used to derive utility. Its score was anchored on a 0.301 to 1.00 scale. The HUI3 consists of eight dimensions (vision, hearing, speech, ambulation, dexterity, emotion, cognition, and pain/discomfort), each with five or six levels giving a total of 972,000 possible health statuses [154]. VAS scaling was used with 504 adults from Ontario, Canada, and the scores were converted to SG using the power function [155]. With regard to HSU instruments, both preference-weighted and unweighted values produced similar results, but only results from the former were reported in Paper 2. The health classification systems for both SF-6D and HUI3 are presented in Appendix 2.

An individual's subjective assessment of health (i.e., VAS) was measured on a continuous scale ranging from 0 (death) to 100 (excellent health) and was based on answers to the following question. "Think about a scale of 0 to 100, with zero being the least desirable state of health that you could imagine and 100 being the best possible health you can imagine in

terms of physical, mental, and social functioning. How would you rate your health state on the scale shown?" (See Appendix 1 for VAS scale and its description). These values were then normalised to a 0 to 1.00 scale.

In Paper 3, three commonly used HRQoL measures were applied: EQ-5D-5L, SF-6D, and VAS. Since both preference-weighted and unweighted values gave similar results, we chose to apply the simple summary scores of EQ-5D-5L and SF-6D by ignoring the scaling of health states.

Household income

Household income was initially measured as a categorical variable in the local currency of the six countries included in the survey. Each country applied different income brackets, which made aggregating the income variable very difficult. Thus, the midpoints of the closed intervals were appropriate scores for those categories as the measure of central tendency, and they approximately represent an average household income of that category [156, 157]. For the top category, which was open-ended, we used the more rigorous approach suggested by Parker and Fenwick [158]. Finally, the median income value of the corresponding income range for each country was converted into US dollars, using the purchasing power parity for actual individual consumption conversion factor in the 2012 OECD database. To address the curvilinear effect of income on SWB, income measures were transformed into a natural logarithm.

Social relationships

Social relationships were measured by four questions from the AQoL instrument [159]. The first two questions asked respondents about the extent of enjoyment and satisfaction with their close relationships (family and friends), and the remaining two questions evaluated their feelings with respect to social isolation and social exclusion, and hence represented social networks with the wider community (see Box 3).

The response level for each question was recoded so that a higher value indicated better social relationships. The reliability coefficient was 0.843, showing good internal consistency. The

response levels of these four questions were then summed and linearly transformed onto a [0 – 1] scale, and considered as a continuous variable.

Box 3: Description of the social relationships variable

- | | |
|--|---|
| <p>a) How much do you enjoy your close relationships (family and friends)?</p> <ol style="list-style-type: none"> 1. Immensely 2. A lot 3. A little 4. Not much 5. I hate it | <p>c) How often do you feel socially isolated?</p> <ol style="list-style-type: none"> 1. Never 2. Rarely 3. Sometimes 4. Often 5. Always |
| <p>b) Your close relationships (family and friends) are:</p> <ol style="list-style-type: none"> 1. Very satisfying 2. Satisfying 3. Neither satisfying nor dissatisfying 4. Dissatisfying 5. Unpleasant 6. Very unpleasant | <p>d) How often do you feel socially excluded (or left out?)</p> <ol style="list-style-type: none"> 1. Never 2. Rarely 3. Sometimes 4. Often 5. Always |

Control variables

In Papers 2 and 3, age, gender, marital status, education, and employment status, as well as disease group and country were considered as control variables. We included the linear effect of age, as well as its quadratic component (age-squared divided by 100) to control for the curvilinear effect of age in Paper 2. Age was categorised into five groups in Paper 3: 18-34, 35-44, 45-54, 55-64, and 65 years and above. Gender (0 = male, and 1 = female) and marital status (0 = no partner/spouse; 1 = living with partner/spouse) have proven to be important determinants of SWB. Further, the highest education level achieved was divided into three categories (0 = high school, 1 = diploma or certificate or trade, and 2 = university).

Employment status was a nominal variable in which respondents were asked to check one of eight choices (full-time job, part-time job, homemaker, unemployed, retired, disability, pensioner, and student). Based on these replies, unemployment status was dichotomised (unemployed vs. all others) to see whether being unemployed had a strong negative effect on SWB. Finally, disease groups and countries were included to capture disease and country-specific heterogeneities. All independent variables used in this study were tested for multicollinearity and were found to be satisfactory, as the variance inflation factors of all independent variables were below 2.0. This value is much less than the generally accepted maximum threshold of 10 [160, 161].

4.3 Statistical analyses

4.3.1 Testing the importance of preference-weighting

In Paper 1, the importance of preference-weighting was assessed by two approaches: construct validity and level of agreement. In the former case, convergent and known-group validities were examined.

Convergent validity

Convergent validity of the preference-weighted and unweighted values of the EQ-5D-5L and the 15D was examined by comparing each instrument to the scores reported on the VAS (N = 7933), and to the D-39 (N = 924) using Spearman rank order correlations. We would expect strong correlations between VAS and the preference-weighted and unweighted values. The ‘energy and mobility’ and ‘anxiety and worry’ subscales of the D-39 were expected to show high correlations with EQ-5D and 15D (indicating good convergent validity), whilst those measuring different concepts (e.g., social burden or sexual functioning) were expected to show low correlations (indicating discriminant validity).

Known-group validity

To assess known-group validity, current standard of living (very good, good, poor, and very poor) and the K10 were used as a reference or anchor. In accordance with a previous study [162], the K10 was divided into four severity levels: ‘likely to be well’ (10 – 19), ‘mild’ (20 – 29), ‘moderate’ (30 – 39), and ‘severe’ (40 – 50). Subjects with better health status and a higher standard of living were hypothesised to have higher scores. The Kruskal-Wallis test and relative efficiency (RE) were employed to explore known-group validity. The RE statistic is defined as the ratio of either chi-squared statistics and F-statistics for construct validity, or squared t-statistics and squared-z statistics for responsiveness [24]. Here RE is given as the ratio of chi-squared of preference-weighted and unweighted values, where an RE value greater than 1 implies that the former has more power in discriminating between meaningfully different groups than the latter.

Level of agreement

The intra-class correlation coefficient (ICC), the Bland-Altman plot and the reduced-major axis (RMA) regression were used to assess agreement. The simple correlation coefficient is

reported to detect any linear association between two measures. It is a measure of linear association with no requirement that the differences between the two methods (e.g., preference-weighted and unweighted measures) be small or fixed across subjects. There are at least two types of ICCs [163]: an individual ICC for consistency, and an ICC for agreement. The former is designed to detect a linear association, but with a fixed difference between the two measures, irrespective of the size of the difference. In other words, if the two measures differ by a constant value for all subjects, which can be small or large, then ICC equals 1. However, the latter attains the value 1 (perfect agreement) only if the linear association between the preference-weighted and unweighted values are the same for every subject in the sample. Our interest was in the actual differences between the preference-weighted and the unweighted values; therefore the ICC for absolute agreement was appropriate.

The Bland-Altman analysis [164] involves computing the mean and the difference between measurement methods for each subject in the sample. It reports the population mean difference between the two methods, and the 95% limits of agreement, which provide a limit within which 95% of the variability between the methods will lie. The mean difference gives the estimated (fixed) bias at the group level. The 95% limits of agreement tells us how far apart measurements by the two methods were more likely to be for most individuals.

RMA regression is symmetrical and is specifically formulated to handle errors in both the dependent and independent variables [165], meaning that interchanging the position of the dependent and independent variables does not affect the estimated result. These features made the RMA regression more appropriate for exploring the relationship between weighted and unweighted values than the standard ordinary least square regression, which is asymmetric and based on the assumption that the independent variable is measured without error. Its intercept and slope allow us to detect fixed and proportional (or systematic) bias between two measures, respectively [166]. Thus, RMA regression with a slope closer to 1 and an intercept near zero is preferred (where perfect agreement occurs with zero intercept and a slope of 1).

4.3.2 Testing the relative importance of health, income, and social relationships

Usually, standardised coefficient estimates measure the relative influence of predictors to measure effect size. Alternatively, a variance decomposition approach can be applied to decompose the relative importance of a variable based on its share of the variance [167].

Standardised estimates overcome the problem of scale differences and units of measurement. The standardised variables and the associated regression coefficients used in this thesis were unit-free so that easy comparisons could be made between coefficients.

An alternative method for assessing importance in a regression model is the coefficient of determination (R^2), which is a measure of the overall goodness of fit. The variance decomposition approach enables researchers to identify how much a particular variable, such as income or health, contributes to the overall explained variation in the model. In Paper 2, we employed a technique called the *Shapely value* [27]. This technique is widely used in various fields, such as marketing [168, 169] and applied economics, when one wishes to assess the relative importance of explanatory variables [170]; but it is new in the study of SWB. Other variance decomposition approaches have been used in previous SWB studies. For example, an approach proposed by Fields allows for a negative values [171], which creates difficulty in interpretation. The Shapely value regression applied in Paper 2 was calculated across all possible combinations of predictors, and was always positive, unlike other net effect measures [169]. To our knowledge, this is the first work to employ this approach in SWB research.

Practically, the standardised coefficients are biased if the predictor variables are correlated. However, the Shapely value regression is a reliable and stable way to estimate the importance of a given variable, even in the presence of high multi-collinearity. It is the most desirable candidate, as it is the only one that satisfies the conditions of efficiency (no values lost), symmetry (equal treatment), and monotonicity (higher share with more marginal contribution) [170, 172]. Note that the Shapely value for any null-player is equal to zero, i.e., any predictor that does not contribute anything to the total variance receives no value. Since these conditions are plausible from a practical perspective, we made use of the Shapely value in our variance decomposition methodology to measure the relative importance of each predictor in addition to standardised coefficients.

The QRM permits us to explore the entire conditional distribution by analysing the effects of predictors at different levels of SWB [173]. Thus, the QRM was applied to evaluate SWB at extreme levels to understand whether a particular policy intervention was equally important for individuals with lower and higher levels of SWB. The QRM is more robust to outliers than standard linear regression, and is semi-parametric as it avoids assumptions about the

parametric distribution of the error process. Thus it is robust to misspecification errors related to heteroscedasticity, non-normality, and others [174]. In this study, we used a simultaneous QRM that enabled us to estimate the effect of the key predictors at different levels of SWB. Results for three different quantiles of SWB were reported: the 25th percentile (lower quartile), the 50th percentile (median), and the 75th percentile (upper quartile). This allowed us to determine whether the contributions of our key variables on well-being differed among individuals with low, average, and high SWB.

4.3.3 Checking the intrinsic vs. the instrumental value of health

Paper 3 investigated the dual role of health in SWB: health *per se* is valuable (and has intrinsic value), but health also has instrumental value as it enhances our capability to flourish socially and financially. Thus, a structural equation model was adopted to examine whether both income and social relationships mediated the association between HRQoL and SWB in patients with chronic conditions. Paper 3 tested the simple conceptual model depicted in Figure 1.

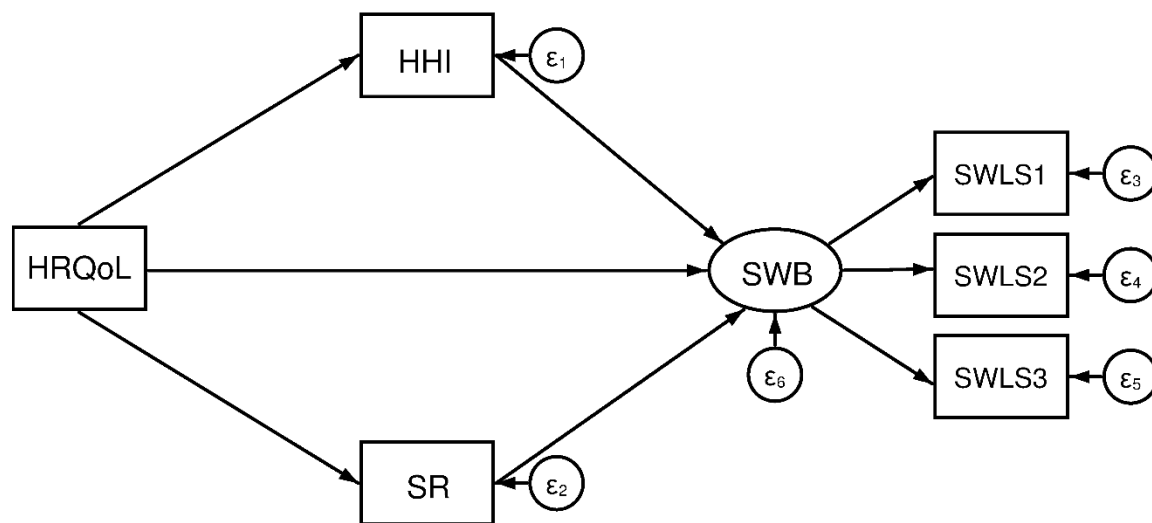

Figure 1 The conceptual model.

HHI, household income (in natural logarithm); SR, social relationships; SWLS1, first item of the SWLS; SWLS2, second item of the SWLS; and SWLS3, third item of the SWLS. The latent variable (SWB) is represented by a circle or ellipse and observed variables (HRQoL, HHI, SR, and the three items of SWLS) are represented by a rectangle or square. A single straight arrow indicates a causal relation from the base of the arrow to the head of the arrow. Error terms for a variable are inserted into the path diagram by drawing an arrow from the value of the error term to the variable with which the term is associated.

The conceptual model demonstrated that better HRQoL would be associated with enhanced SWB and that income and social relationships would explain part of that association. Three distinct measures of health were used: two descriptive systems (EQ-5D-5L and SF-6D), and one direct measure (the VAS). The conceptual model comprised both a structural model (the

link among HRQoL, income, social relationships, and SWB), and the measurement model (the link between SWB and the first three items of satisfaction with life scale: SWLS1, SWLS2, SWLS3). The measurement model (latent construct) was estimated by factor analysis in parallel with the structural part. Maximum likelihood with missing value method of estimation was applied, which handled the problem of missing data by using information from all variables in the analytical model [175]. For correct specification of standard errors and tests of significance, a bootstrapping approach with 5000 replications was applied to test the indirect effects without requiring the assumption of normality [176].

A number of alternative fit indices were examined to assess the model fit to the data: the comparative fit index (CFI), the Tucker–Lewis index (TLI), the root mean square error of approximation (RMSEA) and the standardised root mean squared residual (SRMR). CFI and TLI values equal to or greater than 0.95, and SRMR equal to or less than 0.05 are considered excellent model fits [177]. TLI and CFI values greater than 0.90 are considered acceptable [178]. RMSEA values smaller than 0.05 and 0.08 are considered a close fit and a reasonable fit, respectively [179].

In mediation analyses, variables in a causal relationship can be both causes and effects (e.g., household income and social relationships). Thus, the standard regression paradigm is ill-suited for modelling such a relationship because of its *a priori* assignment of each variable as either a cause or an effect [180]. In our circumstances, the structural equations model (SEM) was more appropriate. The SEM also simplifies testing of mediation hypotheses because it is designed, in part, to test these more complicated mediation models in a single analysis [181]. Thus, the causal relationships in a hypothesised mediation process, the simultaneous nature of the indirect and direct effects, and the dual role the mediator plays as both a cause for the outcome and an effect of the exogenous independent variables, are more appropriately expressed using the SEM.

4.4 Missing information

Despite high overall response rates, over 11% of our sample had missing values on household income. Therefore, the two most widely recommended “state-of-the-art” missing data techniques were applied [182]: full information maximum likelihood and multiple imputation. Both methods depend on the assumption of data missing at random (MAR); however,

ascertaining this is hardly possible as it requires information on missing data. Nevertheless, MAR allows missingness to depend on observed variables. The analyses on the mechanism of missingness indicated that missingness in household income was significantly correlated with other measured variables, which is consistent with the imputation of MAR data.

Multiple imputation was not conducted in Paper 1, since no variable with missing information was involved. In Paper 2, multiple imputation by a chained equation was employed, using Stata® version 14.0 (StataCorp LP, College Station, Texas, USA). This is a flexible approach for specifying an imputation model for each variable [183]. Predictive mean matching was used instead of standard linear regression. Indeed, predictive mean matching restricts the imputed values of a variable to within the range of observed values; it is less sensitive to model misspecification and is robust to skewed data [184]. In Paper 3, the full information maximum likelihood approach was applied using both Stata® version 14.0 and Mplus Version 7.4. In this method, missing values are not replaced or imputed, but handled within the analysis model using all information in the complete dataset [175]. Although each method has its own merits and demerits, under identical assumptions, both methods have produced estimates that were consistent, asymptotically efficient, and asymptotically normal [185].

5 Summary of results

5.1 Does preference-weighting matter?

The key findings from Paper 1 revealed that the differential contribution of weights based on population preference value was quite small, at least at the population level. The evidence of convergent validity was demonstrated by high and significant Spearman's correlation coefficients between the VAS and the preference-weighted and unweighted values (0.60 and above). Similarly, correlations were high (>0.70) for the 'energy and mobility' domain of the D-39 (showing evidence of convergent validity) and low for the 'sexual functioning' domain (indicating discriminant validity). Furthermore, both the preference-weighted and unweighted values of the EQ-5D-5L and 15D showed evidence of known-group validity in detecting significant differences ($p < 0.001$) between the known-group variables. However, preference-weighted EQ-5D-5L scores appeared to be more effective in discriminating between the known groups (e.g., groups with different levels of standard of living and depression), with a relative efficiency that was significantly more than 1. For the 15D, the unweighted value had more discriminating power than the preference-weighted score.

The level of agreement between preference-weighted and unweighted values was strong in both the EQ-5D-5L and the 15D. However, the level of agreement was largely influenced by the scale of the instrument. For instance, the results showed substantial agreement for the EQ-5D-5L (ICC = 0.96; 95% confidence interval [CI]: 0.931 to 0.969) when the unweighted values were anchored on the same scale as that of the weighted scores. When the unweighted values were anchored on the [0 – 1] scale, the agreement was weaker, particularly when the full set of health states ($5^5 = 3,125$) was used instead of the MIC dataset. The ICC dropped from 0.92 to 0.76 when the full set of EQ-5D health states was used, whilst ICC slightly decreased from 0.96 to 0.94 when the health states in the MIC dataset were used. Note that the MIC data comprised only 566 of the 3,125 unique EQ-5D-5L health state combinations. The mean difference more than tripled when we considered the full set of EQ-5D-5L health states: 0.03 (95% CI: 0.029 to 0.035) for adjusted scale, and -0.11 (95% CI: -0.112 to -0.105) for the unadjusted scale. The mean difference was similar in the MIC dataset: about 0.02. The RMA result also revealed good agreement (i.e., the slope was closer to 1 and the intercept closer to 0) with scale adjustment. Despite small differences between preference-weighted and unweighted EQ-5D-5L values at the group level, the BA-plot revealed large inter-

individual differences. The lower and upper 95% limits of agreement were -0.085 (95% CI: -0.087 to -0.083) and 0.131 (95% CI: 0.129 to 0.133), respectively. Nearly 7.4% of the observations were outside these limits of agreement.

With regard to preference-weighted and unweighted 15D values, the ICC was 0.99 ($p < 0.001$), suggesting a more or less perfect agreement. The mean difference was also negligible (-0.001; 95% CI: -0.002 to -0.001). The 95% limits of agreement revealed small differences at the individual level as well: lower limit = -0.038 (95% CI: -0.039 to -0.037) and upper limit = 0.036 (95% CI: 0.035 to 0.037). Only 5.9% of observations were outside of these limits of agreement. RMA results also showed little bias between preference-weighted and unweighted 15D values, with a slope much closer to 1 and an intercept closer to 0. Thus, preference-weighting had a trivial effect in 15D, even at the individual level.

5.2 Relative contribution of health, income, and social relationships

All people would agree with the conventional saying that “it is better to be rich and healthy than poor and sick.” However, the important question is whether SWB is all about health and income. Results from Paper 2 revealed that both health and income were important, but not as important as social connectedness.

With respect to HRQoL, self-reported health (VAS) exhibited a stronger positive effect on SWB than measures of health reported on a descriptive system (EQ-5D-5L, SF-6D, HUI or 15D). For instance, a 1-standard deviation (SD) increase in VAS led to an increase of 0.318 ($p < 0.001$) SD in SWB (*ceteris paribus*), which is more than twice as strong as that seen for the EQ-5D (0.144, $p < 0.001$). The standardised coefficient for the SF-6D was 0.175 ($p < 0.001$). An alternative measure of the relative importance of a variable, variance decomposition, yielded similar results: the share of health in the overall variance of SWB ranged from 19.3% for the EQ-5D to 31.6% for VAS. Results for the HUI3 and the 15D did not change our conclusions, and hence were reported in an appendix to Paper 2. When we compared the three key predictors in terms of standardised coefficients, social relationships showed the strongest effect on SWB, followed by HRQoL. Household income was significantly and positively linked to SWB, but had a weak effect size ($\beta = 0.100$, $p < 0.001$).

Results from variance decomposition showed the same story: social relationships alone accounted for nearly half of the overall variation (50.2%) in SWB when the EQ-5D-5L was used as a measure of HRQoL. When SF-6D was used as a measure of HRQoL, this proportion was 46.8% for social relationships and 23.8% for health. These respective shares became 42% and 31.6% when health was measured by VAS. Household income (in a natural logarithm) was responsible for only around 7% of the variation in SWB.

Results from the QRM suggested that coefficients vary across the three quantiles of SWB, implying that variations due to key variables depend on an individual's level of SWB. For instance, the coefficient of SF-6D at the lower quartile of SWB was nearly twice (0.45; $p < 0.001$) that of the upper quartile (0.22; $p < 0.001$). At the median, a 10% increase in SF-6D values increased SWB by over 3.3%. A similar pattern was observed with the EQ-5D-5L and VAS, but the effect sizes were larger for VAS. Household income and social relationships also had diverse impacts at different quantiles, but the impact of social relationships remained strong and more or less stable along different levels of SWB as compared to health and household income. For example, the effect of EQ-5D-5L on SWB was 0.690 at the lower quartile of SWB, 0.664 at the median, and 0.581 at the upper quartile.

The importance of income was by far stronger at the lower quantile than at the median or higher quantile of SWB. A 100-percentage point increase in income improved the life satisfaction of respondents with lower SWB by about 4 percentage points. The corresponding improvement in life satisfaction at the upper quintile of SWB was approximately halved (2 percentage points). Note that linear regression underestimated the effect of independent variables at the lower quantiles and overestimated at the upper quantiles of SWB distributions.

Consistent with previous studies, age showed a significant U-shaped impact on SWB (with the lowest SWB at around 45 years of age). Both gender and marital status had a significant effect on SWB in the standard regression model: women enjoyed a life satisfaction that was 2 percentage points higher than that of men, and living with partner increased SWB by more than 4 percentage points. Having a high education level conferred greater life satisfaction than a lower education level. For example, respondents with a university degree had a SWB that was about 3.3 percentage points higher than those with a high school diploma (when HRQoL

was measured by EQ-5D-5L). Being unemployed reduced SWB by nearly 7.5 percentage points, which was consistent across all HRQoL measures.

Results from the quantile regression model revealed that the overall effect of age, education, and marital status on SWB were stronger in the groups with lower SWB. For example, married subjects had a 5.7-, 5.3-, and 3.7-percentage point higher SWB than those living without partner/spouse at the lower, median, and upper quartiles of SWB, respectively (when HRQoL was measured by SF-6D). Similarly, while respondents with a university education had around a 4.6-percentage point higher SWB than those with a high school diploma at the lower quartile, this difference was only 2.5 percentage points at the upper quartile (when HRQoL was measured by SF-6D). Gender and unemployment appeared to have a stable contribution across all quantiles of SWB. Note that the share of disease and country variables in the explained overall variance of SWB was small: 1.8% and over 7%, respectively.

5.3 The intrinsic and instrumental value of health

Paper 3 further explored the intrinsic value of health (which had a direct effect on SWB), as well as its instrumental value (its indirect effect via income and social relationships), as illustrated in Figure 1. The fit indices suggested that the model fitted the data well: both CFI and TLI were greater than 0.95; RMSEA and SRMR values were also very good (0.04 and 0.007, respectively).

The results of SEM (all standardised coefficients) revealed that HRQoL measures had a significant positive direct effect on both social relationships and income. Social relationships and income, in turn, had a significant direct effect on SWB. Consequently, there were significant indirect effects of health on SWB via both social relationships and income. For instance, HRQoL measured by EQ-5D-5L had a significant indirect effect on SWB via social relationships ($\beta = 0.208$, $p < 0.001$), as well as via income ($\beta = 0.017$, $p < 0.001$). The total indirect effect of HRQoL measured by EQ-5D-5L on SWB was 0.226, which is by far greater than its direct effect ($\beta = 0.157$). Similar results were obtained with SF-6D. However, when self-reported health (VAS) was used, the direct effect of health on SWB was stronger ($\beta = 0.322$) as compared to its total indirect effect ($\beta = 0.179$).

A direct path from household income to SWB was weak, but significant. Its standardised coefficient was around 0.10 in each model. In summary, the indirect effect of health via social relationships on SWB was 0.208 when HRQoL was measured by EQ-5D-5L, 0.231 when measured by SF-6D, and 0.167 when measured by VAS, representing 54.3%, 50.9%, and 33.3% of the total effect, respectively. In general, both social relationships and household income partially mediated the link between health and SWB.

6 Discussion

6.1 Methodological reflections

6.1.1 Study design

The papers in this thesis have an observational, cross-sectional study design. Cross-sectional studies have no time dimension, thus it is difficult to draw conclusions about causation. However, they can produce consistent and robust results if controlled for potential confounders. The MIC project, which has rich dataset at the individual, household, and national levels, could largely minimise potential confounding problems and avoid spurious correlations between the outcome and predictor variables in Papers 2 and 3. Paper 1 compared two methods, which does not require a distinction between dependent and independent variables, and hence it was not affected by this study design. In all papers, different methodological approaches combined with comprehensive measures of alternative variables were applied to test the consistency of the findings. However, a number of methodological considerations related to the reliability and validity of key variables used in this thesis need to be discussed.

6.1.2 Reliability and validity of health-related quality of life and subjective well-being

To evaluate the change in an individual's quality of life, it is essential to choose the most appropriate outcome measurement. The selection of HRQoL and SWB measures were based on earlier studies and the aims of the present thesis. All HRQoL and SWB measures used have been validated and used in earlier studies in different countries and different patient groups. In this thesis we used four HSU instruments (EQ-5D, SF-6D, 15D, HUI3), and one self-reported direct measure of health (VAS) to measure HRQoL. The multiple-item SWLS was preferred as a SWB measure over a single-item global life satisfaction question, because it is more comprehensive in terms of the coverage of well-being, and more reliable [186]. A single-item global life satisfaction was also considered, but performed less well than the multiple-item SWLS. Therefore, Diener's SWLS was used as a SWB measure in Papers 2 and 3.

Reliability

The HRQoL and SWB measures used have shown satisfactory reliability both in earlier studies and in this thesis. Reliability refers to the ability of a measure to reproduce the same

value in two or more separate administrations when there has been no change in quality of life [43]. It refers to the degree of accuracy and stability of a given instrument. Two measures are usually included in the assessment of scales [187]: a measure of the homogeneity of each of the items and the test-retest reliability. The former is commonly measured by Cronbach's alpha. The latter is a measure of the extent to which the same score will be predicted from the same individual at a second point in time [188].

Table 4. Tests for reliability and validity of HRQoL and SWB measures

Outcomes	Correlation coefficients*								Cronbach's α	KW* χ^2
	IL	Hap	MH	Cop	Rel	SW	Pa	SN		
EQ-5D	0.77	0.58	0.56	0.64	0.57	0.59	0.76	0.35	0.81	148.05
SF-6D	0.68	0.64	0.67	0.71	0.67	0.64	0.67	0.35	0.84	121.90
HUI3	0.74	0.64	0.59	0.68	0.62	0.63	0.70	0.49	0.69	156.14
15D	0.78	0.65	0.65	0.74	0.65	0.66	0.71	0.48	0.88	182.25
VAS ^a	0.59	0.59	0.51	0.64	0.54	0.55	0.54	0.31	-	129.93
SWLS	0.35	0.72	0.60	0.62	0.60	0.60	0.31	0.24	0.92	163.13
SWB ^b	0.37	0.73	0.59	0.63	0.60	0.60	0.32	0.24	0.94	177.54

IL, independent living; Hap, happiness; MH, mental health; Cop, coping; Rel, relationship; SW, self-worth; Pa, pain; SN, senses (are eight AQoL dimensions). KW, Kruskal-Wallis H test statistics (to test for discriminative validity using smoking as a known-group variable). Smoking has four categories (non-smokers, 1-10, 11-20, or ≥ 21 cigarettes per day).

^a VAS is measured by a single questionnaire for which Cronbach's α cannot be computed.

^b Measured by the first three items of SWLS.

* $p < 0.0001$.

In the present study, the lowest 'scale reliability coefficient' (Cronbach's alpha = 69%) was registered for HUI3. The EQ-5D, SF-6D, 15D, and SWB had a Cronbach's alpha of over 80%, which is by far higher than the recommended minimum standard of 70% (see Table 4). The HUI3 uses a narrow definition of health; a 'within-the-skin' (or disability-based) descriptive system alone without social or handicap-based dimensions [189]. This may explain its lower Cronbach's alpha value. Although the nature of our data does not allow us to determine test-retest reliability, studies have shown the evidence of the test-retest reliability and reproducibility of HSU instruments [43, 159] and of SWB [190, 191]. The aggregate measure of the variable social relationships was constructed based on four questions related to close friends and families, as well as connectedness to the wider community. The scale

reliability coefficient reported for this variable was quite high (over 80%), indicating a sufficient level of internal consistency.

Validity

Another important concern for assessing the performance of any measurement scale is validity, which has a number of components, among which content and construct validities are important to mention. A valid instrument measures what it is intended to measure [187]. Content validity refers to the extent to which an instrument includes or covers representative items or dimensions of the health domain and is sufficiently sensitive to changes, while construct validity refers to the extent to which an instrument agrees with other instruments or indicators of the outcome measure [57, 159]. The latter was consistently tested empirically for the instruments we used. Content validity was formally tested by considering the correlation of each HRQoL and SWB measure with the dimensions of other similar measures. The correlations between the eight dimensions of the AQoL [159] and the EQ-5D-5L, SF-6D, HUI3, and 15D were quite large, indicating the sensitivity of these dimensions (Table 4). The correlation coefficient for SWB was significant ($p < 0.0001$), and this correlation was stronger with the happiness dimension (0.73), which was expected, since both overlap in meaning.

Construct validity constitutes two subcategories: convergent and discriminant validity. These subcategories work together; there is no evidence of construct validity without evidence for both convergent and discriminant validity. Thus, construct validity refers to whether different measures of constructs that theoretically should be related are, in fact, related to each other (convergence), and whether measures of constructs that theoretically should not be related, are, in fact, not related (discriminant validity). All HRQoL and SWB measures used in this thesis showed both convergent and discriminative validities (Table 4). All measures were also effective in discriminating between known groups: they detected significant ($p < 0.0001$) differences between smoking status (see the last column of Table 4).

The validation test results and apparent sensitivity of the instruments we used varied significantly by measurement method and disease group [192]. The SWB index (in Papers 2 and 3) had good psychometric properties and conformed well to accepted operationalisations of global SWB [193]. In this thesis, only the first three items of SWB were considered, as the response to the last two items appeared to be influenced by age. Excluding the last two items

resulted in a higher scale reliability coefficient, as well as better convergent validity on most dimensions of AQoL (Table 4). Several studies also revealed the empirical validity of the HSU instruments (for a recent review, see Finch *et al.* [194] and Richardson *et al.* [195]). In general, the validity of all measures applied in this thesis was satisfactory, which was largely confirmed by available evidence (although there is no gold standard against which these measures could be compared). The novelty of this thesis lies in the application of different measures of HRQoL, including diagnosis types, which enabled us to confirm the consistency of the findings. The application of multi-item variables, such as social relationships, HRQoL (except VAS), and SWB are considered superior since they are more comprehensive in terms of their coverage. The use of alternative statistical analyses, like regression techniques that are robust to distributional assumptions of error terms, can also be considered an advantage in establishing consistent results.

6.1.3 Systematic errors and missingness

The study samples used in this thesis were obtained from the MIC project and included individuals aged 18 years and above from six OECD countries. The response rate for the survey participants was high. After a strict selection process, nearly 83% of participants were retained. Self-selection bias might have occurred, since respondents volunteered to complete the online survey. However, the high response rate and stringent selection procedures (combined with large sample size) demonstrate the quality and completeness of the data. Consequently, it is less likely that selection bias influenced the findings. Thus, given the multi-national nature of the data, it is possible to generalise the findings from this study to other developed countries.

Missingness (non-responses) may lead to biased parameter estimates and reduce the power of the model if the missing information is not random [196]. Nearly all missing information in our study was on the household income variable (over 11%). In Papers 2 and 3, household income was the key predictor of SWB; therefore we imputed missing values on this variable using two modern techniques: multiple imputation and full information maximum likelihood. In Paper 2, multiple imputation by chained equation was applied. This method allows to specify an appropriate imputation model for each variable. For instance, we used predictive mean matching instead of conventional regression to impute household income, which is the most relevant model when data are skewed (as was the case with income). In Paper 3, the

maximum likelihood method was used, which handles missing values by using all information contained in the complete dataset. Both approaches produce consistent and unbiased results if the data are MAR. Although the use of imputed data did not render results different from those acquired from complete-case analyses, they did show relatively smaller standard errors (indicating more precision in parameter estimates).

6.2 Discussion of results

An important issue in measuring HRQoL is whether to include patients' preferences for health states in the evaluation. Paper 1 examined the relative importance of preference-weighting in two HSU instruments, the EQ-5D-5L and the 15D, that are most widely applied in economic evaluations of health care. Unlike other general instruments like the SF-36 [197], HSU instruments provide a single numerical index that reflects societal preferences through health states. Furthermore, HSU instruments have several applications beyond health economic evaluations, including the assessment of population health, the impact of disease, and measuring health outcomes in clinical trials [24, 25], none of which necessarily require preference-weighting. Unweighted (or equally-weighted) HRQoL measures are most common in these applications. In this thesis, HRQoL measures that use a simple summary score in which equal weights are applied to each level and dimension were referred to as unweighted measures.

HSU measures involve the application of complex algorithms to create utility weights, which has been debated. Jenkinson [198] and Prieto and Sacristán [26] questioned the need for utility weights, as the correlation between the weighted and unweighted measures are very high. Both weighted and unweighted values provide similar results at least at the population level, including in the present study, which showed a mean difference of close to 0.02 in EQ-5D-5L measures. This difference is much lower than the clinically important difference reported for the EQ-5D-3L (0.074) [199] and the EQ-5D-5L (0.063) [200]. The results of the preference-weighted and unweighted measures for each instrument were also comparable with regard to the performance of convergent and known-group validities. With respect to agreement between preference-weighted and unweighted values, the EQ-5D-5L showed considerable discrepancy at the individual level, particularly in the absence of scale adjustment. This discrepancy was reduced when both preference-weighted and unweighted

values were given on the same scale. For EQ-5D-5L, the clear discrepancy at the individual level was evidenced by the width of the 95% limits of agreement, which was 0.216.

With regard to the 15D, a fine-graded instrument with a comprehensive set of dimensions, a simple normalisation of data on a 0 to 1 scale yielded similar values to the use of preference-weighted tariffs. High ICC and negligible mean differences confirmed this result. The absolute mean difference (0.001) was by far lower than the generic minimum important changes (0.015) reported for the 15D scores [201]. For the 15D, the width of the 95% limits of agreement was also narrow (0.074). Hence, the differential contribution of preference-weights in 15D is minimal.

Most psychology studies suggest that greater reliability and validity might be achieved by using simple unweighted values instead of the increasingly complex weighting algorithms [202-204]. Furthermore, Wilke *et al.* [24] found no difference in sensitivity to change between weighted and unweighted values, although the weighted values discriminated better between disease groups, and unweighted values provided a greater test-retest reliability for the EQ-5D-3L and the HUI3. In a similar vein, our results revealed that preference-weighting produces a small difference when the unweighted values are adjusted to the same scale as the preference-weighted values in the EQ-5D-5L, at least at the group level. In the 15D, this difference was negligible.

Scaling differences play an important role in the distinctions between preference-weighted and unweighted values. Such scale effects arise mainly due to the methodological approach used to construct preference-weights [53]. The English EQ-5D-5L tariff applies composite TTO combined with DCE to elicit preferences. This process results in an effective range of 1.281 (-0.281 to 1) for the English EQ-5D-5L tariff. Nevertheless, the unweighted scale obtained using a unity-based normalisation can never go below zero. In this thesis, this scale difference was normalised by linearly adjusting the unweighted scale onto the same scale as its weighted counterpart. Accordingly, preferences for the trade-off between gains in quantity and quality of life (the scaling issue) were indirectly reflected in the adjusted scale. Thus, any difference from the weighted scale was only the non-equal importance weighting, depending on the health dimensions in which a given quality gain occurred.

Obviously, the weighting algorithm produces different scales for the calibration of tariffs, and it is this scale difference that accounts mainly for the difference between preference-weighted and unweighted values. After adjusting for this scale difference, the relative importance of dimensions involved make only a small difference. For example, considering the full set of EQ-5D-5L health states in this thesis ($N = 3,125$), the absolute agreement between weighted and unweighted values was high ($ICC = 0.92$). Failure to adjust for such scale differences substantially reduced this agreement (to 0.76). In the case of the 15D, both weighted and unweighted values never fell below zero, because 15D uses VAS (on 0 to 100 scale) to elicit preferences. Since there was no scale effect problem in the 15D, the agreement was very high ($ICC = 0.99$), indicating a trivial difference between the weighted and unweighted values.

In Paper 2, the contribution of both weighted and unweighted values from the HSU instruments for SWB were examined, and gave similar results. However, only results from the former were reported along with the contributions of social relationships and income. The standardised coefficients and variance decomposition results suggested that social relationships have the strongest associations with SWB, followed by health. Household income had a steady positive effect on SWB.

HRQoL was an important contributor to SWB. However, the degree of this contribution depended on whether HRQoL was measured indirectly through descriptive systems (e.g., EQ-5D or SF-6D) or directly on a rating scale (VAS). The latter had a stronger effect on SWB than the former. For instance, the Shapley value decomposition revealed that the proportion of variation in SWB associated uniquely with VAS was 15.8% after controlling for all socio-demographic factors including disease group and country variables. However, the respective contribution of SF-6D and EQ-5D was 10.8% and 8.7%. Previous studies have also documented that health accounts for 4% to 16% of the variance in SWB [98]. The standardised coefficients give similar results: a 1-SD increase in VAS resulted in an increase of 0.318 SD in SWB, which was more than twice the effect of EQ-5D. The standardised coefficients for HUI3 and 15D were similar (about 0.20), and are provided as an appendix to Paper 2. A more appealing reason for the strong effect of VAS on SWB as compared to HSU instruments could be related to the wording of VAS questions. These questions makes specific reference to the social and mental dimensions of health in addition to physical health. This appears to increase the relative importance of VAS (and reduce the relative importance

of social relationships) for SWB. Furthermore, VAS represents the overall assessment of an individual's own (experienced) health state, whereas HSU instruments represent the valuation of specific health descriptive systems by members of the general public [10]. Thus, VAS is conceptually closer to SWB, which is also self-rated, and hence better predicts SWB than EQ-5D or SF-6D.

Quantile regression results evidenced a decreasing importance of health status with increasing quantiles of SWB. For example, the effect of SF-6D at the lower quartile of SWB was about 0.45, which was twice that of the higher quartile. Thus, health is much more important for individuals with lower SWB than those with higher SWB. Similar findings have been reported in the literature: studies by Binder and Coad [28] and Graham and Nikolova [30] revealed that the coefficients of health decrease across the quantiles of SWB, although the HRQoL measures used differ from those in the present study. In general, good health tends to be associated with greater happiness, and as a matter of necessity, health is more important for individuals with lower SWB.

Economic theory suggests that an increase in individual income should lead to an increase in SWB through higher utility, though the effect size is quite small. In Paper 2, the marginal contribution of income was small (7% alone). In a similar vein, other studies have reported a weak positive association between income and SWB [105, 205]. These studies also showed that SWB increases with income but at a lower rate, which corroborates our findings. The reason for this steady rise in SWB with income could be multi-factorial. However, well-known explanations include the relative income hypothesis and possible individual adaptations. Clearly, individual adaptations, sometimes referred to as the *hedonic treadmill* [206] or the *preference drift* [207], where higher incomes are accompanied by rising expectations, may lead to a temporary or small increase in SWB. For instance, using longitudinal data from the German Socio-Economic Panel, Bartolini *et al.* [126] found that change in income predicts a considerable change in SWB, but the joint negative predictions due to income comparison and income adaptation made up for about three-fourths of the gains from favourable changes in income. Frey and Stutzer [120] also estimated that adaptation compensates for about two-thirds of the benefits of any increase in income.

Results from quantile regression also suggested that the contribution of household income to SWB is larger for individuals with lower SWB than those with higher SWB. This makes sense because individuals at the lower quantile of SWB may be poorer than those at the higher quantile. In our study the coefficient of log-income was 0.039 at the lower quartile (25th percentile) and was halved (to 0.020) at the upper quartile (75th percentile). Although the effect of income on SWB was strong among poorer individuals, it remained significantly important even at higher levels of income. This suggests that the effect of income diminishes as people get richer, but does not satiate once a certain level of income is achieved. In line with this, previous studies have found that SWB increases with income, but with diminishing returns [4].

Furthermore, Paper 2 used a composite measure of social relationships that revealed the strongest contribution to SWB. This variable accounted for half of the overall explained variation in SWB when health was measured by the EQ-5D. The contribution of social relationship remained high when the SF-6D and VAS were used: 47 and 42%, respectively. Research showed that the presence and quality of an individual's social relationships, such as friendships, relationships with family, and wider community participation, is closely related to SWB [208]. Close relationships with family and friends provide love, meaning, and support, and hence increase our feelings of self-worth, whilst broader networks within the wider community bring a sense of belonging that is essential for happiness [208, 209]. People with good social relationships are less likely to experience sadness, loneliness, low self-esteem and problems with eating and sleeping [210]. This is because close ties with families and friends require self-disclosure (i.e., sharing of personal issues and feelings) [211], which plays an important role in the relief of stress and depression, and hence improves SWB.

Similarly, broader social connections with the community contribute to happiness, enabling the individual and the larger society to flourish. In contrast, studies have revealed that social isolation and exclusion deteriorate the sense of meaning people have in their lives [212] and adversely influence SWB. In this study, social relationships were self-reported using a multi-item scale, which could strengthen their association. Findings from quantile regression demonstrated that a good social relationship is very important across all levels of SWB, though this importance diminished slightly in the upper quartile. The effect of social relationships on SWB was 0.690 in the lower quartile, 0.664 at the median and 0.581 in the

higher quartile when HRQoL was measured by EQ-5D. This implies that the contribution of social relationships remains large even for individuals with high SWB.

Paper 2 acknowledged that these key variables have a stronger impact for individuals with low SWB than those with high SWB. If the policy-relevant variables identified here are less important for individuals with high SWB, what other variables affect high well-being? It seems that individual variations or ‘set-points’ explain more SWB at the upper end. The set-point theory predicts that individuals have differing, but stable levels of SWB (mainly due to personality traits and other factors which are partly hereditary or determined early in life), though a significant minority of people register long-term change [213]. Still, many other, undiscovered factors may exist and warrant further research.

Paper 3 continued to explore how health, household income, and social relationships are linked to SWB, emphasising the intrinsic value of health (its direct bearings on SWB) and its instrumental value (its indirect effect via household income and social relationships). The findings revealed that more than 54% of the total effects of health (as measured by EQ-5D-5L) on SWB was mediated by social relationships. The percentage mediated via social relationships remained high when SF-6D and VAS were used as a measure of HRQoL: over 50% and about 33%, respectively. The standardised effect of EQ-5D-5L via income was only 0.017, just 4.4% of the total effects of health on SWB. These results suggest that health is important, but as much for its importance via social networks. The effect through income was weak, but significant.

The explanations for the weak effect of income were provided above. In addition to relative income effects and adaptation theory, a stronger explanation could be related to the so-called *set-point theory* [214], which suggests that favourable changes in income do not have lasting effects on SWB, the latter being determined mainly by personality traits and genetic endowments. The bounded nature of the SWB scale also has implications for the diminishing marginal return of SWB with increasing income [215]. Since life satisfaction was measured on a bounded scale, the increase in SWB with rising income was trivial once SWB reached a fairly high level. Nevertheless, the positive effect of income on SWB appeared to be significant and is supported by earlier studies [9, 14, 15].

Social relationships, which include family relationships, friendships, and wider social networks were the most important determinant of SWB. A 1-SD change in the variable social relationships resulted in a 0.480 SD change in SWB when HRQoL was measured by EQ-5D-5L. Similarly, the impact of health problems on social relationships was strong; the standardised effect of EQ-5D-5L on social relationships was 0.434. It follows that the indirect effect of health on SWB via social relationships was also strong (0.208). It has been argued that the need to belong and to have social relationships is a fundamental human motivation [216], and as such, social relationships have direct implications on SWB as well as a mediating role with health.

The weaker income effect and stronger social relationship effect of SWB could be explained in terms of intrinsic and extrinsic goals. Intrinsic goals are those that are inherently rewarding and do not depend on external validation, while extrinsic goals are typically pursued as a means to some end (external reward) such as financial success, status, or image [23]. Research has shown little or no adaptation for goods and activities characterised by intrinsic attributes and of strong adaptations for those with extrinsic attributes [127]. Kasser and Ryan [217] also argued that the relative importance of extrinsic aspirations for financial success was associated with lower self-actualisation and SWB, while the relative importance of intrinsic aspirations for self-actualisation, affiliation, and community feeling were associated with higher well-being and lower distress. Thus, social relationships appear to be a source of intrinsic goals, which have the capacity to enhance SWB more than the extrinsic motivations associated with financial success. In line with this, Easterlin [218] suggested that in the pursuit of happiness it would be wise to allocate more effort to social relationships and less to acquiring material goods. Studies have also suggested that, while the contribution of income appears to be more context-dependent and momentary, the role of close relationships and the wider community to predict SWB is strong and more stable, and it may not be easily affected by external circumstances [17].

In Paper 3, we included only individuals with chronic conditions. Having a chronic illness would certainly influence individuals' economic and social participation, and hence their overall SWB. Clearly, individuals with chronic conditions place more emphasis on their illness than on material well-being, which will dampen the effect of income on SWB. Furthermore, individuals with chronic illnesses tend to isolate themselves from their social

network and engage in activities that take place in the private sphere. This would exacerbate feelings of alienation from families and close friends, eventually deteriorating their overall well-being. Research has also found that as chronic illness prevails, social networks are weakened, leaving individuals with chronic conditions at greater risk of social isolation [219]. Therefore, social relationships are a more sound and stable predictor of well-being than financial success.

7 Conclusions and policy implications

7.1 Conclusions

This thesis examined the issue of preference-weighting in HRQoL (EQ-5D-5L and 15D), and then explored the relative importance of these HRQoL measures (along with income and social relationships) for SWB. The findings of this thesis can be summarised as follows:

- a) The importance of preference-weighting is quite small, at least at the group level. Preference-weighting in both the EQ-5D-5L and 15D did not improve their convergent and predictive validity. Thus, greater reliability and validity might be achieved with a simple adjustment to unweighted scales than with the use of increasingly complex techniques involved in the development of utility algorithms. However, there are theoretical reasons for the use of health state-specific utility weights rather than a simple summary score obtained from the use of equal weights (e.g., in QALY calculations). Nevertheless, unweighted measures can be applied in population health studies, clinical trials, and when comparing burdens of disease, without introducing further complexities through the scaling of HSU that uses preferences from the general population. Still, the scaling of HSU instruments introduced through elicitation of utility weights reflect the fact that the preferences over quantity vs. quality of life remains important.
- b) The composite measure of social relationships is the most important variable for SWB followed by health. Income is the least important variable, though it is still a significant predictor of SWB. Assuming HRQoL is measured by EQ-5D-5L, the social relationships variable alone accounted for more than half of the total explained variation in SWB. However, the study acknowledges the integrated relative importance of health, income, and social relationships for SWB.
- c) As a matter of necessity, health and income are more important for individuals with lower SWB than those with higher SWB. Social relationships are a more or less stable predictor of SWB, though this variable has a slightly stronger effect at lower levels of SWB.
- d) Considering a sample of individuals with chronic conditions, health problems appeared to influence SWB directly as well as indirectly through income and social relationships. While the indirect effect of health via income is weaker, the effect through social relationships is quite large. Thus, health is important for SWB, but its indirect effect via social connectedness is equally important.

7.2 Policy implications and further research

When adjusted for scale-length, the relative importance of dimensions plays a small role, at least at the group level, in HSU instruments as compared to its unweighted counterpart. The important implication for researches in this field is to explore descriptive items instead of placing the emphasis on a sophisticated algorithm for the development of utility weights (see also Richardson *et al.* [53]), which is costly and time-consuming. For policy-makers, it might be more appropriate to select measures that cover most of the domains of HRQoL, particularly in public health policy. In this thesis, a linearly-adjusted unweighted model for EQ-5D and 15D instruments was presented. Future research that accommodates the non-linearities along the level changes, as well as differences in the relative importance assigned to the dimensions, is also warranted.

This thesis has also shown that social relationships provide a more solid foundation for happiness than money, and that income is more important for the poor than the rich. The policy implication here is that less emphasis should be placed on income, except for the poor, and more attention should be paid to social relationships. This could be achieved primarily through education and policies that encourage social networking. In addition to health and financial benefits, reducing unemployment and providing leisure facilities would also provide more opportunities for socializing. An important message for researchers engaged in the development of health outcome measures would be to include a meaningful item on social indicators. Using people with chronic conditions, we have also shown that social relationship played an important role, either directly or as a mediator between HRQoL and SWB. Thus, public health interventions should be tailored more towards improving social relationships for people with chronic conditions as well as for those with lower levels of SWB.

The findings of this thesis were based on data from a cross-sectional online survey. This may raise concerns about the representativeness of the sample in terms of unobserved characteristics. Thus, further research with panel data that can easily handle such unobserved heterogeneity is needed to confirm the consistency of our findings. In addition, it is difficult to identify some external factors (appropriate for policy direction) that predict SWB at the upper end. Individual variations (personality traits) may play an important role for people with higher levels of SWB, and future research is required to identify what exactly determines life satisfaction at these higher levels.

Allocation of limited resources in health care requires the assessment of broader concepts of HRQoL than those commonly used in health economic evaluations, such as the EQ-5D or SF-6D, which emphasise physical health. For instance, following the WHO definition of health, a recent Delphi procedure has shown that economic evaluations of health care interventions need to put more emphasis on mental and social dimensions [220]. Although progress has been made in constructing a broader health-related SWB as a more comprehensive outcome measure [221], further research is needed in this direction. Particularly, future research should emphasise extending the existing QALY concept by developing a broad generic measure of quality of life to calculate the 'Q' in QALY for use in economic evaluation, which could be applicable across the fields of health care, social care, and public health.

8 References

1. Grad, F. P. (2002). The Preamble of the Constitution of the World Health Organization. *Bulletin of the World Health Organization*, 80, 981-981.
2. Diener, E., Napa Scollon, C., & Lucas, R. (2009). The Evolving Concept of Subjective Well-Being: The Multifaceted Nature of Happiness. In E. Diener (Ed.), *Assessing Well-Being* (Vol. 39, pp. 67-100, Social Indicators Research Series): Springer Netherlands.
3. Stiglitz, J. E., Sen, A and Fitoussi, J.P. (2009). Report by the Commission on Measurement of Economic Performance and Social Progress. Retrived from <http://www.stiglitz-senfitoussi.fr/en/index.htm>.
4. Frey, B. S., & Stutzer, A. (2010). *Happiness and Economics: How the Economy and Institutions Affect Human Well-Being*. Princeton University Press.
5. Kahneman, D., Krueger, A. B., Schkade, D., Schwarz, N., & Stone, A. (2004). Toward National Well-Being Accounts. *American Economic Review*, 94(2), 429-434, doi:10.1257/0002828041301713.
6. Dolan, P., & Metcalfe, R. (2012). Measuring Subjective Wellbeing: Recommendations on Measures for Use by National Governments. *Journal of social policy*, 41(02), 409-427.
7. Waldron, S. (2010). Measuring Subjective Wellbeing in the UK. Retrived from http://measuringsubjectivewellbeingforpublicpolic_tcm77-230291.pdf.
8. Easterlin, R. A. (1974). Does Economic Growth Improve the Human Lot? : Some Empirical Evidence. *Nations and households in economic growth : essays in honor of Moses Abramovitz*, 89-125.
9. Deaton, A. (2008). Income, Health, and Well-Being around the World: Evidence from the Gallup World Poll. *Journal of Economic Perspectives*, 22(2), 53-72, doi:doi: 10.1257/jep.22.2.53.
10. Cubí-Mollá, P., de Vries, J., & Devlin, N. (2014). A Study of the Relationship between Health and Subjective Well-Being in Parkinson's Disease Patients. *Value in Health*, 17(4), 372-379, doi:<http://dx.doi.org/10.1016/j.jval.2014.03.002>.
11. Helliwell, J. F., & Putnam, R. D. (2004). The Social Context of Well-Being. *Philosophical Transactions of the Royal Society B: Biological Sciences*, 359(1449), 1435-1446, doi:10.1098/rstb.2004.1522.
12. Saphire-Bernstein, S. & Taylor, S.E.. (2013). Close Relationships and Happiness. In I. Boniwell, & A.C. Ayers (Eds.), *The Oxford Book of Happiness* (pp. 821-833). London: Oxford University Press.
13. Dolan, P., Peasgood, T., & White, M. (2008). Do We Really Know What Makes Us Happy? A Review of the Economic Literature on the Factors Associated with Subjective Well-Being. *Journal of Economic Psychology*, 29(1), 94-122, doi:<http://dx.doi.org/10.1016/j.joep.2007.09.001>.
14. Easterlin, R. A. (1995). Will Raising the Incomes of All Increase the Happiness of All? *Journal of Economic Behavior & Organization*, 27(1), 35-47, doi:[http://dx.doi.org/10.1016/0167-2681\(95\)00003-B](http://dx.doi.org/10.1016/0167-2681(95)00003-B).
15. Ferrer-i-Carbonell, A. (2005). Income and Well-Being : An Empirical Analysis of the Comparison Income Effect. *Journal of public economics*, 89(5/6), 997-1019, doi:<https://doi.org/10.1016/j.jpubeco.2004.06.003>.
16. Rojas, M. (2011). Happiness, Income, and Beyond. *Applied Research in Quality of Life*, 6(3), 265-276, doi:10.1007/s11482-011-9153-7.

17. Gleibs, I. H., Morton, T. A., Rabinovich, A., Haslam, S. A., & Helliwell, J. F. (2013). Unpacking the Hedonic Paradox: A Dynamic Analysis of the Relationships between Financial Capital, Social Capital and Life Satisfaction. *British Journal of Social Psychology*, 52(1), 25-43.
18. Okun, M. A., Stock, W. A., Haring, M. J., & Witter, R. A. (1984). Health and Subjective Well-Being - a Meta-Analysis. *International Journal of Aging & Human Development*, 19(2), 111-132, doi:Doi 10.2190/Qgjn-0n81-5957-Haqd.
19. Nes, R. B., Røysamb, E., Tambs, K., Harris, J. R., & Reichborn-Kjennerud, T. (2006). Subjective Well-Being: Genetic and Environmental Contributions to Stability and Change. *Psych Medicine*, 36(07), 1033-1042, doi: 10.1017/S0033291706007409.
20. Schnittker, J. (2008). Happiness and Success: Genes, Families, and the Psychological Effects of Socioeconomic Position and Social Support. *American Journal of Sociology*, 114, S233-S259, doi:Doi 10.1086/592424.
21. DeNeve, K. M., & Cooper, H. (1998). The Happy Personality: A Meta-Analysis of 137 Personality Traits and Subjective Well-Being. *Psychol Bull*, 124(2), 197-229.
22. E., R., & Diener, E. (2009). Personality and Subjective Well-Being. In E. Diener (Ed.), *The Science of Well-Being: The Collected Works of Ed Diener* (pp. 75-102). Dordrecht: Springer Netherlands.
23. Huppert, F. A. (2014). The State of Wellbeing Science. In *Wellbeing: A Complete Reference Guide, Interventions and Policies to Enhance Wellbeing* (Vol. 6, pp. 1-50): John Wiley & Sons, Ltd.
24. Wilke, C. T., Pickard, A. S., Walton, S. M., Moock, J., Kohlmann, T., & Lee, T. A. (2010). Statistical Implications of Utility Weighted and Equally Weighted HRQoL Measures: An Empirical Study. *Health Econ*, 19(1), 101-110, doi:10.1002/hec.1467.
25. Parkin, D., Rice, N., & Devlin, N. (2010). Statistical Analysis of EQ-5D Profiles: Does the Use of Value Sets Bias Inference? *Med Decis Making*, 30(5), 556-565, doi:10.1177/0272989x09357473.
26. Prieto, L., & Sacristán, J. (2004). What Is the Value of Social Values? The Uselessness of Assessing Health-Related Quality of Life through Preference Measures. *BMC Medical Research Methodology*, 4(1), 1-9, doi:<http://10.1186/1471-2288-4-10>.
27. Shapley, L. S. (1953). A Value for N-Person Games. In H. W. Kuhn & A. W. Tucker (Eds.), *The Theory of Games* (Vol. II, pp. 307-317, Annals of Mathematical Studies). Princeton: Princeton University Press.
28. Binder, M., & Coad, A. (2011). From Average Joe's Happiness to Miserable Jane and Cheerful John: Using Quantile Regressions to Analyze the Full Subjective Well-Being Distribution. *Journal of Economic Behavior & Organization*, 79(3), 275-290, doi:<http://dx.doi.org/10.1016/j.jebo.2011.02.005>.
29. Binder, M., & Coad, A. (2015). Heterogeneity in the Relationship between Unemployment and Subjective Wellbeing: A Quantile Approach. *Economica*, 82(328), 865-891, doi:10.1111/ecca.12150.
30. Graham, C., & Nikolova, M. (2015). Bentham or Aristotle in the Development Process? An Empirical Investigation of Capabilities and Subjective Well-Being. *World Development*, 68(0), 163-179, doi:<http://dx.doi.org/10.1016/j.worlddev.2014.11.018>.
31. Yuan, H., & Golpelwar, M. (2013). Testing Subjective Well-Being from the Perspective of Social Quality: Quantile Regression Evidence from Shanghai, China. *Social Indicators Research*, 113(1), 257-276, doi:10.1007/s11205-012-0091-z.

32. Hohl, K. (2009). Beyond the Average Case: The Mean Focus Fallacy of Standard Linear Regression and the Use of Quantile Regression for the Social Sciences. Retrieved from <http://ssrn.com/abstract=1434418>.
33. WHO (2016). Introducing Whoqol: Measuring Quality of Life. Retrieved from <http://www.who.int/healthinfo/survey/whoqol-qualityoflife/en/>.
34. Healthy People 2020. (2010). Foundation Health Measure Report: Health-Related Quality of Life and Well-Being. Retrieved from <https://www.healthypeople.gov/sites/default/files/HRQoLWBFULLReport.pdf>.
35. Ferrans, C. E., Zerwic, J. J., Wilbur, J. E., & Larson, J. L. (2005). Conceptual Model of Health-Related Quality of Life. *J Nurs Scholarsh*, 37(4), 336-342.
36. Revicki, D. A. (1989). Health-Related Quality of Life in the Evaluation of Medical Therapy for Chronic Illness. *J Fam Pract*, 29(4), 377-380.
37. Lin, X.-J., Lin, I. M., & Fan, S.-Y. (2013). Methodological Issues in Measuring Health-Related Quality of Life. *Tzu Chi Medical Journal*, 25(1), 8-12, doi:<http://dx.doi.org/10.1016/j.tcmj.2012.09.002>.
38. Testa, M. A., & Simonson, D. C. (1996). Assessment of Quality-of-Life Outcomes. *N Engl J Med*, 334(13), 835-840, doi:10.1056/nejm199603283341306.
39. Till, J. E., Osoba, D., Pater, J. L., & Young, J. R. (1994). Research on Health-Related Quality of Life: Dissemination into Practical Applications. *Quality of Life Research*, 3(4), 279-283, doi:10.1007/bf00434902.
40. Parrish, R. G. (2010). Measuring Population Health Outcomes. *Prev Chronic Dis*, 7(4), A71.
41. Drummond, M. F., Sculpher, M. J., Torrance, G. W., O'Brien, B. J., & Stoddart, G. L. (2015). *Methods for the Economic Evaluation of Health Care Programme*. 4th ed. Oxford University Press: Oxford.
42. O'Connor, R. (1993). Issues in the Measurement of Health-Related Quality of Life. National Centre for Health Program Evaluation, Working Paper Number 30. Retrieved from http://www.rodconnorassoc.com/issues_in_the_measurement_of_qua.htm.
43. Brazier, J., Ratcliffe, J., Saloman, J., & Tsuchiya, A. (2017). *Measuring and Valuing Health Benefits for Economic Evaluation*. Oxford University Press.
44. Ferrans, C. E. (2007). Differences in What Quality-of-Life Instruments Measure. *J Natl Cancer Inst Monogr*, (37), 22-26, doi:10.1093/jncimonographs/lgm008.
45. Fitzpatrick, R., Davey, C., Buxton, M. J., & Jones, D. R. (1998). Evaluating Patient-Based Outcome Measures for Use in Clinical Trials. *Health Technol Assess*, 2(14), i-iv, 1-74.
46. ePROVIDE (2017). Clinical Outcome Assessment and Patient-Reported Outcomes Information. Retrieved from <https://eprovide.mapi-trust.org/>.
47. Guyatt, G. H., Feeny, D. H., & Patrick, D. L. (1993). Measuring Health-Related Quality of Life. *Annals of Internal Medicine*, 118(8), 622-629, doi:10.7326/0003-4819-118-8-199304150-00009.
48. Patrick, D. L., & Deyo, R. A. (1989). Generic and Disease-Specific Measures in Assessing Health Status and Quality of Life. *Med Care*, 27(3 Suppl), S217-232.
49. Gold, M. R. (1996). *Cost-Effectiveness in Health and Medicine*. Oxford University Press, USA.
50. Torrance, G. W. (1987). Utility Approach to Measuring Health-Related Quality-of-Life. *Journal of Chronic Diseases*, 40(6), 593-600, doi:Doi 10.1016/0021-9681(87)90019-1.
51. Torrance, G. W. (1986). Measurement of Health State Utilities for Economic Appraisal. *J Health Econ*, 5(1), 1-30.

52. Richardson, J., McKie, J., & Bariola, E. (2011). Review and Critique of Health Related Multi Attribute Utility Instruments. Retrived from <https://books.google.no/books?id=5iUXnQAACAAJ>.
53. Richardson, J., Iezzi, A., & Khan, M. A. (2015). Why Do Multi-Attribute Utility Instruments Produce Different Utilities: The Relative Importance of the Descriptive Systems, Scale and 'Micro-Utility' Effects. *Qual Life Res*, doi:10.1007/s11136-015-0926-6.
54. Wisløff, T., Hagen, G., Hamidi, V., Movik, E., Klemp, M., & Olsen, J. A. (2014). Estimating Qaly Gains in Applied Studies: A Review of Cost-Utility Analyses Published in 2010. *Pharmacoeconomics*, 32(4), 367-375, doi:<http://10.1007/s40273-014-0136-z>.
55. Neumann, P. J., Goldie, S. J., & Weinstein, M. C. (2000). Preference-Based Measures in Economic Evaluation in Health Care. *Annu Rev Public Health*, 21, 587-611, doi:<http://10.1146/annurev.publhealth.21.1.587>.
56. Alex G, M. J., & Wyrwich, K. W. (2003). Health Utility Measures and the Standard Gamble. *Academic Emergency Medicine*, 10(4), 360-363, doi:10.1111/j.1553-2712.2003.tb01349.x.
57. Brazier, J., Ratcliffe, J., Salomon, J. A., & Tsuchiya, A. (2017). *Measuring and Valuing Health Benefits for Economic Evaluation*. Oxford University Press.
58. Torrance, G. W. (1976). Social Preferences for Health States: An Empirical Evaluation of Three Measurement Techniques. *Socio-Economic Planning Sciences*, 10(3), 129-136, doi:[http://dx.doi.org/10.1016/0038-0121\(76\)90036-7](http://dx.doi.org/10.1016/0038-0121(76)90036-7).
59. Robinson, A., & Spencer, A. (2006). Exploring Challenges to Tto Utilities: Valuing States Worse Than Dead. *Health Econ*, 15(4), 393-402, doi:10.1002/hec.1069.
60. Dolan, P. (1997). Modeling Valuations for EuroQol Health States. *Med Care*, 35, doi:10.1097/00005650-199711000-00002.
61. Rowen, D., Brazier, J., Young, T., Gaugris, S., Craig, B. M., King, M. T., & Velikova, G. (2011). Deriving a Preference-Based Measure for Cancer Using the EORTC QLQ-C30. *Value Health*, 14, doi:10.1016/j.jval.2011.01.004.
62. Devlin, N. J., Tsuchiya, A., Buckingham, K., & Tilling, C. (2011). A Uniform Time Trade Off Method for States Better and Worse Than Dead: Feasibility Study of the 'Lead Time' Approach. *Health Economics*, 20(3), 348-361, doi:10.1002/hec.1596.
63. Augustovski, F., Rey-Ares, L., Irazola, V., Oppe, M., & Devlin, N. J. (2013). Lead Versus Lag-Time Trade-Off Variants: Does It Make Any Difference? *Eur J Health Econ*, 14 Suppl 1, S25-31, doi:10.1007/s10198-013-0505-0.
64. Verschuuren, M. (2006). Quality Adjusted Life Years and Trade Off Exercises: Exploring Methodology and Validity. Retrived from <https://dspace.library.uu.nl/bitstream/handle/1874/8811/index.htm?sequence=9>.
65. Tilling, C., Devlin, N., Tsuchiya, A., & Buckingham, K. (2010). Protocols for Time Tradeoff Valuations of Health States Worse Than Dead: A Literature Review. *Med Decis Making*, 30(5), 610-619, doi:10.1177/0272989x09357475.
66. Devlin, N., Buckingham, K., Shah, K., Tsuchiya, A., Tilling, C., Wilkinson, G., & van Hout, B. (2013). A Comparison of Alternative Variants of the Lead and Lag Time TTO. *Health Econ*, 22(5), 517-532, doi:10.1002/hec.2819.
67. Janssen, B. M. F., Oppe, M., Versteegh, M. M., & Stolk, E. A. (2013). Introducing the Composite Time Trade-Off: A Test of Feasibility and Face Validity. *The European Journal of Health Economics*, 14(Suppl 1), 5-13, doi:10.1007/s10198-013-0503-2.

68. Craig, B. M., Busschbach, J. J., & Salomon, J. A. (2009). Keep It Simple: Ranking Health States Yields Values Similar to Cardinal Measurement Approaches. *J Clin Epidemiol*, 62(3), 296-305, doi:[10.1016/j.jclinepi.2008.07.002](https://doi.org/10.1016/j.jclinepi.2008.07.002).
69. Norman, R., Cronin, P., & Viney, R. (2013). A Pilot Discrete Choice Experiment to Explore Preferences for EQ-5D-5L Health States. *Applied Health Economics and Health Policy*, 11(3), 287-298, doi:<http://10.1007/s40258-013-0035-z>.
70. Bansback, N., Brazier, J., Tsuchiya, A., & Anis, A. (2012). Using a Discrete Choice Experiment to Estimate Health State Utility Values. *Journal of Health Economics*, 31(1), 306-318, doi:<http://dx.doi.org/10.1016/j.jhealeco.2011.11.004>.
71. Louviere, J. J., & Woodworth, G. (1983). Design and Analysis of Simulated Consumer Choice or Allocation Experiments: An Approach Based on Aggregate Data. *Journal of Marketing Research*, 20(4), 350-367, doi:10.2307/3151440.
72. McFadden, D. (1974). Conditional Logit Analysis of Qualitative Choice Behavior. In P. Zarembka (Ed.), *Frontiers in Econometrics* (pp. 105-142): Academic Press.
73. Brazier, J., Rowen, D., Yang, Y., & Tsuchiya, A. (2012). Comparison of Health State Utility Values Derived Using Time Trade-Off, Rank and Discrete Choice Data Anchored on the Full Health-Dead Scale. *Eur J Health Econ*, 13(5), 575-587, doi:10.1007/s10198-011-0352-9.
74. Robinson, A., Spencer, A., & Moffatt, P. (2015). A Framework for Estimating Health State Utility Values within a Discrete Choice Experiment: Modeling Risky Choices. *Med Decis Making*, 35(3), 341-350, doi:10.1177/0272989x14554715.
75. Bleichrodt, H. (2002). A New Explanation for the Difference between Time Trade-Off Utilities and Standard Gamble Utilities. *Health Economics*, 11(5), 447-456, doi:10.1002/hec.688.
76. Bleichrodt, H., & Johannesson, M. (1997). An Experimental Test of a Theoretical Foundation for Rating-Scale Valuations. *Medical Decision Making*, 17(2), 208-216, doi:10.1177/0272989X9701700212.
77. Diener, E. (1984). Subjective Well-Being. *Psychological Bulletin*, 95(3), 572-575.
78. Tatarikiewicz, W. (1976). *Analysis of Happiness*. Martinus Nijhoff.
79. Diener, E., & Scollon, C. N. (2003). Subjective Well-Being Is Desirable, but Not the Summum Bonum. Paper Presented at the Workshop on Well-Being, Minneapolis, Mn, USA. Retrived from http://ink.library.smu.edu.sg/sooss_research/912.
80. Graham, C. (2010). The Challenges of Incorporating Empowerment into the HDI: Some Lessons from Happiness Economics and Quality of Life Research. Retrived from http://hdr.undp.org/sites/default/files/hdrp_2010_13.pdf.
81. Bentham, J. (1789). *An Introduction to the Principle of Morals and Legislations*. (Reprinted Oxford, UK: Blackwell, 1948).
82. Mill, J. S. (1871). *Utilitarianism*. 4 ed. Vol. 3. London: Longmans, Green, Reader, and Dyer.
83. Kahneman, D., & Riis, J. (2005). Living and Thinking About It: Two Perspectives on Life. In N. Baylis, F. A. Huppert & B. Keverne (Eds.), *The Science of Well-Being* (pp. 285–301): Oxford University Press.
84. Donovan, N., Halpern, D., & Sargeant, R. (2002). Life Satisfaction: The State of Knowledge and Implications for Government. London: Prime Minister's Strategy Unit.
85. Krueger, A. B., & Schkade, D. A. (2008). The Reliability of Subjective Well-Being Measures. *Journal of public economics*, 92(8-9), 1833-1845, doi:10.1016/j.jpubeco.2007.12.015.

86. Diener, E. (2000). Subjective Well-Being: The Science of Happiness and a Proposal for a National Index. *American Psychologist*, 55(1), 34-43, doi:10.1037/0003-066X.55.1.34.
87. Diener, E., Emmons, R. A., Larsen, R. J., & Griffin, S. (1985). The Satisfaction with Life Scale. *J Pers Assess*, 49(1), 71-75, doi:10.1207/s15327752jpa4901_13.
88. Diener, E., & Seligman, M. (2004). Beyond Money: Toward an Economy of Well-Being. *Psychological Science in the Public Interest*, 5(1), 1-31, doi:10.2307/40062297.
89. MacKerron, G., & Mourato, S. (2013). Happiness Is Greater in Natural Environments. *Global Environmental Change*, 23(5), 992-1000, doi:<http://dx.doi.org/10.1016/j.gloenvcha.2013.03.010>.
90. Stone, A. A., Shiffman, S. S., & DeVries, M. W. (1999). Ecological Momentary Assessment. In D. Kahneman, E. Diener & N. Schwarz (Eds.), *Well-Being: The Foundations of Hedonic Psychology* (Vol. xii, pp. 26-39). New York, NY, US: Russell Sage Foundation.
91. Kahneman, D., Krueger, A. B., Schkade, D. A., Schwarz, N., & Stone, A. A. (2004). A Survey Method for Characterizing Daily Life Experience: The Day Reconstruction Method. *Science*, 306(5702), 1776-1780, doi:10.1126/science.1103572.
92. Ryff, C. D. (1989). Happiness Is Everything, or Is It? Explorations on the Meaning of Psychological Well-Being. *Journal of Personality and Social Psychology*, 57(6), 1069-1081, doi:10.1037/0022-3514.57.6.1069.
93. Huppert, F. A., Marks, N., Clark, A., Siegrist, J., Stutzer, A., Vittersø, J., & Wahrendorf, M. (2009). Measuring Well-Being across Europe: Description of the ESS Well-Being Module and Preliminary Findings. *Social Indicators Research*, 91(3), 301-315, doi:10.1007/s11205-008-9346-0.
94. Sen, A. (2001). *Development as Freedom*. Oxford: OUP.
95. Kahneman, D., & Krueger, A. B. (2006). Developments in the Measurement of Subjective Well-Being. *Journal of Economic Perspectives*, 20(1), 3-24, doi:doi: 10.1257/089533006776526030.
96. Diener, E., Suh, E. M., Lucas, R. E., & Smith, H. L. (1999). Subjective Well-Being: Three Decades of Progress. *Psychological Bulletin*, 125(2), 276-302, doi:10.1037//0033-2909.125.2.276.
97. Oswald, A. J., & Powdthavee, N. (2008). Does Happiness Adapt? A Longitudinal Study of Disability with Implications for Economists and Judges. *Journal of Public Economics*, 92(5), 1061-1077, doi:<http://dx.doi.org/10.1016/j.jpubeco.2008.01.002>.
98. Larson, R. (1978). 30 Years of Research on Subjective Well-Being of Older Americans. *Journals of Gerontology*, 33(1), 109-125.
99. Richardson, J., Chen, G., Khan, M. A., & Iezzi, A. (2015). Can Multi-Attribute Utility Instruments Adequately Account for Subjective Well-Being? *Med Decis Making*, 35(3), 292-304, doi:10.1177/0272989x14567354.
100. Easterlin, R. A. (1974). Does Economic Growth Improve the Human Lot? Some Empirical Evidence. *Nations and households in economic growth*, 89, 89-125.
101. Stevenson, B., & Wolfers, J. (2013). Subjective Well-Being and Income: Is There Any Evidence of Satiation? *The American Economic Review*, 103(3), 598-604.
102. Stevenson, B., & Wolfers, J. (2008). Economic Growth and Subjective Well-Being: Reassessing the Easterlin Paradox: National Bureau of Economic Research.
103. Diener, E., & Biswas-Diener, R. (2002). Will Money Increase Subjective Well-Being?: A Literature Review and Guide to Needed Research. *Social Indicators Research*, 57(2), 119-169, doi:10.2307/27526987.

104. Layard, R., Mayraz, G., & Nickell, S. (2008). The Marginal Utility of Income. *Journal of Public Economics*, 92(8), 1846-1857, doi:<http://dx.doi.org/10.1016/j.jpubeco.2008.01.007>.
105. Easterlin, R. A. (2001). Income and Happiness: Towards a Unified Theory. *The Economic Journal*, 111(473), 465-484, doi:10.1111/1468-0297.00646.
106. Layard, R., Mayraz, G., & Nickell, S. (2010). Does Relative Income Matter? Are the Critics Right? In E. Diener, H. J.F. & D. Kahneman (Eds.), *International Differences in Well-Being*. Oxford: Oxford University Press.
107. Easterlin, R. A. (2005). Diminishing Marginal Utility of Income? Caveat Emptor. *Social Indicators Research*, 70(3), 243-255, doi:DOI 10.1007/s11205-004-8393-4.
108. Cummins, R. A., Eckersley, R., Lo, S. K., & Okerstrom, E. (2004). Australian Unity Wellbeing Index Survey 10. Retrived from <http://www.acqol.com.au/reports/survey-reports/survey-010-report.pdf>.
109. Howell, R. T., & Howell, C. J. (2008). The Relation of Economic Status to Subjective Well-Being in Developing Countries: A Meta-Analysis. *Psychological bulletin*, 134(4), 536.
110. Clark, A., Georgellis, Y., & Sanfey, P. (2001). Scarring: The Psychological Impact of Past Unemployment. *Economica*, 68(270), 221-241.
111. Nordenmark, M., Strandh, M., & Layte, R. (2006). The Impact of Unemployment Benefit on the Mental Well-Being of the Unemployed in Sweden, Ireland and Great Britain. *European Societies*, 8(1), 83-110, doi:10.1080/14616690500491415.
112. Blanchflower, D. G., & Oswald, A. J. (2004). Well-Being over Time in Britain and the USA. *Journal of Public Economics*, 88(7), 1359-1386, doi:[http://dx.doi.org/10.1016/S0047-2727\(02\)00168-8](http://dx.doi.org/10.1016/S0047-2727(02)00168-8).
113. Gerdtham, U.-G., & Johannesson, M. (2001). The Relationship between Happiness, Health, and Socio-Economic Factors: Results Based on Swedish Microdata. *The Journal of Socio-Economics*, 30(6), 553-557, doi:[http://dx.doi.org/10.1016/S1053-5357\(01\)00118-4](http://dx.doi.org/10.1016/S1053-5357(01)00118-4).
114. Clark, A. E., & Oswald, A. J. (1994). Unhappiness and Unemployment. *The Economic Journal*, 104(424), 648-659, doi:10.2307/2234639.
115. Flouri, E. (2004). Subjective Well-Being in Midlife: The Role of Involvement of and Closeness to Parents in Childhood. [journal article]. *Journal of Happiness Studies*, 5(4), 335-358, doi:10.1023/b:johs.0000048461.21694.92.
116. Helliwell, J. F. (2003). How's Life? Combining Individual and National Variables to Explain Subjective Well-Being. *Economic Modelling*, 20(2), 331-360, doi:[http://dx.doi.org/10.1016/S0264-9993\(02\)00057-3](http://dx.doi.org/10.1016/S0264-9993(02)00057-3).
117. Stutzer, A. (2004). The Role of Income Aspirations in Individual Happiness. *Journal of Economic Behavior & Organization*, 54(1), 89-109, doi:<http://dx.doi.org/10.1016/j.jebo.2003.04.003>.
118. Dolan, P., Peasgood, T., & White, M. (2006). Review of Research on the Influences on Personal Well-Being and Application to Policy Making. Retrived from http://www.defra.gov.uk/science/project_data/DocumentLibrary/SD12005/SD12005_4017_FRP.pdf.
119. Di Tella, R., MacCulloch, R. J., & Oswald, A. J. (2001). Preferences over Inflation and Unemployment: Evidence from Surveys of Happiness. *American Economic Review*, 91(1), 335-341, doi:doi: 10.1257/aer.91.1.335.
120. Frey, B. S., & Stutzer, A. (2002). *Happiness and Economics: How the Economy and Institutions Affect Human Well-Being*. Princeton University Press.

121. Haller, M., & Hadler, M. (2006). How Social Relations and Structures Can Produce Happiness and Unhappiness: An International Comparative Analysis. *Social Indicators Research*, 75(2), 169-216.
122. Clark, A., & Alternatives, D. (2003). Inequality-Aversion and Income Mobility: A Direct Test. Retrieved from <https://books.google.no/books?id=IEHISAAACAAJ>.
123. Clark, A. E., & Lelkes, O. (2005). Deliver Us from Evil: Religion as Insurance. Retrieved from <https://halshs.archives-ouvertes.fr/halshs-00590570>.
124. OECD. (2001). The Evidence on Social Capital. In *The Well-Being of Nations: The Role of Human and Social Capital* (pp. 39-63). Paris: OECD.
125. Putnam, R. D. (2001). *Bowling Alone: The Collapse and Revival of American Community*: Simon and Schuster.
126. Bartolini, S., Bilancini, E., & Sarracino, F. (2012). Predicting the Trend of Well-Being in Germany: How Much Do Comparisons, Adaptation and Sociability Matter? *Social Indicators Research*, 114(2), 169-191, doi:10.1007/s11205-012-0142-5.
127. Becchetti, L., Pelloni, A., & Rossetti, F. (2008). Relational Goods, Sociability, and Happiness. *Kyklos*, 61(3), 343-363, doi:10.1111/j.1467-6435.2008.00405.x.
128. Helliwell, J. F. (2006). Well-Being, Social Capital and Public Policy: What's New? *The Economic Journal*, 116(510), C34-C45, doi:DOI: 10.1111/j.1468-0297.2006.01074.x.
129. Gallagher, E. N., & Vella-Brodrick, D. A. (2008). Social Support and Emotional Intelligence as Predictors of Subjective Well-Being. *Personality and Individual Differences*, 44(7), 1551-1561, doi:<http://dx.doi.org/10.1016/j.paid.2008.01.011>.
130. Walen, H. R., & Lachman, M. E. (2000). Social Support and Strain from Partner, Family, and Friends: Costs and Benefits for Men and Women in Adulthood. *Journal of Social and Personal Relationships*, 17(1), 5-30, doi:doi:10.1177/0265407500171001.
131. Cummins, R. A., Eckersley, R., Pallant, J., van Vugt, J., & Misajon, R. (2003). Developing a National Index of Subjective Wellbeing: The Australian Unity Wellbeing Index. *Social Indicators Research*, 64(2), 159-190, doi:10.1023/a:1024704320683.
132. Argyle, M. (1999). Causes and Correlates of Happiness. In D. Kahneman, E. Diener & N. Schwarz (Eds.), *Well-Being: The Foundations of Hedonic Psychology* (pp. 353-373). New York, NY, US: Russell Sage Foundation.
133. Lucas, R. E., Clark, A. E., Georgellis, Y., & Diener, E. (2003). Reexamining Adaptation and the Set Point Model of Happiness: Reactions to Changes in Marital Status. *Journal of Personality and Social Psychology*, 84(3), 527-539, doi:10.1037/0022-3514.84.3.527.
134. Blanchflower, D. G., & Oswald, A. J. (2008). Is Well-Being U-Shaped over the Life Cycle? *Social Science & Medicine*, 66(8), 1733-1749, doi:<http://dx.doi.org/10.1016/j.socscimed.2008.01.030>.
135. Graham, C., & Chattopadhyay, S. (2013). Gender and Well-Being around the World. *International Journal of Happiness and Development*, 1(2), 212-232, doi:10.1504/ijhd.2013.055648.
136. Haring, M. J., Stock, W. A., & Okun, M. A. (1984). A Research Synthesis of Gender and Social Class as Correlates of Subjective Well-Being. *Human Relations*, 37(8), 645-657, doi:10.1177/001872678403700805.
137. Louis, V. V., & Zhao, S. (2002). Effects of Family Structure, Family SES, and Adulthood Experiences on Life Satisfaction. *Journal of Family Issues*, 23(8), 986-1005, doi:doi:10.1177/019251302237300.

138. van den Berg, B., & Ferrer, I. C. A. (2007). Monetary Valuation of Informal Care: The Well-Being Valuation Method. *Health Econ*, 16(11), 1227-1244, doi:10.1002/hec.1224.
139. Dorsett, R., C., R., & Weale, M. (2015). Intergenerational and Inter-Ethnic Well-Being: An Analysis for the UK Theme: Trade, Investment & Productivity, Employment & Social Policy. Niesr Discussion Paper Number: 451, *Understanding Society Home*. University of Essex.
140. Knies, G., Nandi, A., & Platt, L. (2016). Life Satisfaction, Ethnicity and Neighbourhoods: Is There an Effect of Neighbourhood Ethnic Composition on Life Satisfaction? *Social Science Research*, 60, 110-124, doi:<http://dx.doi.org/10.1016/j.ssresearch.2016.01.010>.
141. Boyce, C. J. (2010). Understanding Fixed Effects in Human Well-Being. *Journal of Economic Psychology*, 31(1), 1-16.
142. Tellegen, A., Lykken, D. T., Bouchard, T. J., Jr., Wilcox, K. J., Segal, N. L., & Rich, S. (1988). Personality Similarity in Twins Reared Apart and Together. *J Pers Soc Psychol*, 54(6), 1031-1039.
143. Kasser, T. (2003). *The High Price of Materialism*. MIT Press.
144. Ryan, L., & Dziurawiec, S. (2001). Materialism and Its Relationship to Life Satisfaction. *Social Indicators Research*, 55(2), 185-197.
145. Kittiprapas, S., Sawangfa, O., Fisher, C., Powdthavee, N., & Nitnitiphrut, K. (2009). Happiness: New Paradigm, Measurement, and Policy Implications, *the Synthesis from the International Conference "Happiness and Public Policy", July 18-19, 2007*. Bangkok, Thailand: Happy Society Associate.
146. Richardson, J., Iezzi, A., & Maxwell, A. (2012). Cross-National Comparison of Twelve Quality of Life Instruments: Mic Paper 1 Background, Questions, Instruments. Research Paper 76. Retrived from <http://www.buseco.monash.edu.au/centres/che/pubs/researchpaper76.pdf>.
147. Devlin, N., Shah, K., Feng, Y., Mulhern, B., & Van Hout, B. (2016). Valuing Health-Related Quality of Life: An Eq-5d-5l Value Set for England. Retrived from <https://www.ohe.org/publications/valuing-health-related-quality-life-eq-5d-5l-value-set-england>.
148. Sintonen, H. (1994). The 15-D Measure of Health Related Quality of Life: Reliability, Validity and Sensitivity of Its Health State Descriptive System. Retrived from <http://www.buseco.monash.edu.au/centres/che/pubs/wp41.pdf>.
149. Sintonen, H. (2001). The 15d Instrument of Health-Related Quality of Life: Properties and Applications. *Annals of Medicine*, 33(5), 328-336, doi:<http://doi:10.3109/07853890109002086>.
150. Boyer, J. G., & Earp, J. A. (1997). The Development of an Instrument for Assessing the Quality of Life of People with Diabetes. Diabetes-39. *Med Care*, 35(5), 440-453.
151. Hultell, D., & Gustavsson, J. P. (2008). A Psychometric Evaluation of the Satisfaction with Life Scale in a Swedish Nationwide Sample of University Students. *Personality and Individual Differences*, 44(5), 1070-1079, doi:<http://dx.doi.org/10.1016/j.paid.2007.10.030>.
152. Zou, C., Schimmack, U., & Gere, J. (2013). The Validity of Well-Being Measures: A Multiple-Indicator-Multiple-Rater Model. *Psychological Assessment*, 25(4), 1247-1254, doi:<http://10.1037/a0033902>.
153. Brazier, J., Roberts, J., & Deverill, M. (2002). The Estimation of a Preference-Based Measure of Health from the Sf-36. *Journal of Health Economics*, 21(2), 271-292, doi:[http://dx.doi.org/10.1016/S0167-6296\(01\)00130-8](http://dx.doi.org/10.1016/S0167-6296(01)00130-8).

154. Feeny, D., Furlong, W., Boyle, M., & Torrance, G. (1995). Multi-Attribute Health Status Classification Systems. *Pharmacoeconomics*, 7(6), 490-502, doi:<http://10.2165/00019053-199507060-00004>.
155. Feeny, D., Furlong, W., Torrance, G. W., Goldsmith, C. H., Zhu, Z., DePauw, S., Denton, M., & Boyle, M. (2002). Multiattribute and Single-Attribute Utility Functions for the Health Utilities Index Mark 3 System. *Med Care*, 40, doi:10.1097/00005650-200202000-00006.
156. Hout, M. (2004). Getting the Most out of the GSS Income Measures (GSS Methodological Report 101). Retrived from http://publicdata.norc.org:41000/gss/DOCUMENTS/REPORTS/Methodological_Reports/MR101.pdf.
157. Sarracino, F. (2013). Determinants of Subjective Well-Being in High and Low Income Countries: Do Happiness Equations Differ across Countries? *The Journal of Socio-Economics*, 42(0), 51-66, doi:<http://dx.doi.org/10.1016/j.socec.2012.11.006>.
158. Parker, R. N., & Fenwick, R. (1983). The Pareto Curve and Its Utility for Open-Ended Income Distributions in Survey Research. *Social Forces*, 61(3), 872-885, doi:10.2307/2578140.
159. Richardson, J., Iezzi, A., Khan, M., & Maxwell, A. (2014). Validity and Reliability of the Assessment of Quality of Life (AQoL)-8DMulti-Attribute Utility Instrument. *The Patient - Patient-Centered Outcomes Research*, 7(1), 85-96, doi:10.1007/s40271-013-0036-x.
160. O'brien, R. (2007). A Caution Regarding Rules of Thumb for Variance Inflation Factors. *Quality & Quantity*, 41(5), 673-690, doi:10.1007/s11135-006-9018-6.
161. Pevalin, D. J., & Robson, K. (2009). The Stata Survival Manual.
162. Jorm, A. F., Griffiths, K. M., Christensen, H., Parslow, R. A., & Rogers, B. (2004). Actions Taken to Cope with Depression at Different Levels of Severity: A Community Survey. *Psychol Med*, 34(2), 293-299.
163. McGraw, K. O., & Wong, S. P. (1996). "Forming Inferences About Some Intraclass Correlations Coefficients": Correction. *Psychological Methods*, 1(4), 390, doi:<http://10.1037/1082-989X.1.4.390>.
164. Bland, J. M., & Altman, D. G. (1986). Statistical Methods for Assessing Agreement between Two Methods of Clinical Measurement. *Lancet*, 1(8476), 307-310.
165. Smith, R. J. (2009). Use and Misuse of the Reduced Major Axis for Line-Fitting. *Am J Phys Anthropol*, 140(3), 476-486, doi:10.1002/ajpa.21090.
166. Ludbrook, J. (2010). Linear Regression Analysis for Comparing Two Measurers or Methods of Measurement: But Which Regression? *Clin Exp Pharmacol Physiol*, 37(7), 692-699, doi:10.1111/j.1440-1681.2010.05376.x.
167. Menard, S. (2004). Six Approaches to Calculating Standardized Logistic Regression Coefficients. *The American Statistician*, 58(3), 218-223, doi:10.1198/000313004X946.
168. Lipovetsky, S., & Conklin, M. (2001). Analysis of Regression in Game Theory Approach. *Applied Stochastic Models in Business and Industry*, 17(4), 319-330, doi:10.1002/asmb.446.
169. Conklin, M., Powaga, K., & Lipovetsky, S. (2004). Customer Satisfaction Analysis: Identification of Key Drivers. *European Journal of Operational Research*, 154(3), 819-827, doi:[http://dx.doi.org/10.1016/S0377-2217\(02\)00877-9](http://dx.doi.org/10.1016/S0377-2217(02)00877-9).
170. Shorrocks, A. (2013). Decomposition Procedures for Distributional Analysis: A Unified Framework Based on the Shapley Value. *The Journal of Economic Inequality*, 11(1), 99-126, doi:10.1007/s10888-011-9214-z.

171. Fields, G. S. (2003). Accounting for Income Inequality and Its Change : A New Method, with Application to the Distribution of Earnings in the United States. *Research in labor economics : RLE ; an annual compilation of research*, 22, 1-38.
172. Huettner, F., & Sunder, M. (2012). Axiomatic Arguments for Decomposing Goodness of Fit According to Shapley and Owen Values. 1239-1250, doi:10.1214/12-EJS710.
173. Koenker, R. (2005). *Quantile Regression*. Cambridge University Press.
174. Chay, K. Y., & Powell, J. L. (2001). Semiparametric Censored Regression Models. *Journal of Economic Perspectives*, 15(4), 29-42, doi:doi: 10.1257/jep.15.4.29.
175. Enders, C. K., & Bandalos, D. L. (2001). The Relative Performance of Full Information Maximum Likelihood Estimation for Missing Data in Structural Equation Models. *Structural Equation Modeling: A Multidisciplinary Journal*, 8(3), 430-457, doi:10.1207/S15328007SEM0803_5.
176. Preacher, K. J., & Hayes, A. F. (2008). Asymptotic and Resampling Strategies for Assessing and Comparing Indirect Effects in Multiple Mediator Models. [journal article]. *Behavior Research Methods*, 40(3), 879-891, doi:10.3758/brm.40.3.879.
177. Hu, L. t., & Bentler, P. M. (1999). Cutoff Criteria for Fit Indexes in Covariance Structure Analysis: Conventional Criteria Versus New Alternatives. *Structural Equation Modeling: A Multidisciplinary Journal*, 6(1), 1-55, doi:10.1080/10705519909540118.
178. Kline, R. B. (2011). *Principles and Practice of Structural Equation Modeling*. NY, USA: Guilford Press.
179. McDonald, R. P., & Ho, M. H. (2002). Principles and Practice in Reporting Structural Equation Analyses. *Psychological Methods*, 7(1), 64-82, doi:<http://dx.doi.org/10.1037/arc0000004>.
180. MacKinnon, D. P., & Fairchild, A. J. (2009). Current Directions in Mediation Analysis. *Current directions in psychological science*, 18(1), 16-20, doi:10.1111/j.1467-8721.2009.01598.x.
181. MacKinnon, D. P. (2008). *Introduction to Statistical Mediation Analysis*. NY, USA: Lawrence Erlbaum Associates.
182. Schafer, J. L., & Graham, J. W. (2002). Missing Data: Our View of the State of the Art. *Psychol Methods*, 7(2), 147-177.
183. White, I. R., Royston, P., & Wood, A. M. (2011). Multiple Imputation Using Chained Equations: Issues and Guidance for Practice. *Statistics in Medicine*, 30(4), 377-399, doi:10.1002/sim.4067.
184. Little, R. J. A. (1988). Missing-Data Adjustments in Large Surveys. *Journal of Business & Economic Statistics*, 6(3), 287-296, doi:10.2307/1391878.
185. Allison, P. D. (2002). *Missing Data: Quantitative Applications in the Social Sciences*. Thousand Oaks, California: Sage Publications.
186. Van Praag, B. M., Frijters, P., & Ferrer-i-Carbonell, A. (2003). The Anatomy of Subjective Well-Being. *Journal of Economic Behavior & Organization*, 51(1), 29-49.
187. Streiner, D. L., Norman, G. R., & Cairney, J. (2015). *Health Measurement Scales: A Practical Guide to Their Development and Use*. Oxford: Oxford University Press.
188. Richardson, J., Iezzi, A., Khan, M. A., & Maxwell, A. (2014). Validity and Reliability of the Assessment of Quality of Life (AQoL)-8d Multi-Attribute Utility Instrument. *The Patient*, 7(1), 85-96, doi:10.1007/s40271-013-0036-x.
189. Torrance, G. W., Boyle, M. H., & Horwood, S. P. (1982). Application of Multi-Attribute Utility Theory to Measure Social Preferences for Health States. *Oper Res*, 30(6), 1043-1069.

190. Krueger, A. B. (2009). *Measuring the Subjective Well-Being of Nations: National Accounts of Time Use and Well-Being*. Chicago: University of Chicago Press.
191. Lyubomirsky, S., & Lepper, H. S. (1999). A Measure of Subjective Happiness: Preliminary Reliability and Construct Validation. *Soc Indicators Res*, 46(2), 137-155.
192. Richardson, J., Iezzi, A., Khan, M. A., Chen, G., & Maxwell, A. (2016). Measuring the Sensitivity and Construct Validity of 6 Utility Instruments in 7 Disease Areas. *Med Decis Making*, 36(2), 147-159, doi:10.1177/0272989x15613522.
193. Diener, E., & Locas, R. E. (1999). Personality and Subjective Well-Being. In D. Kahneman, E. Diener & N. Schwarz (Eds.), *Well-Being: Foundations of Hedonic Psychology* (pp. 213-229). New York: Russell Sage Foundation.
194. Finch, A. P., Brazier, J. E., & Mukuria, C. (2017). What Is the Evidence for the Performance of Generic Preference-Based Measures? A Systematic Overview of Reviews. *The European J of Health Economics*, doi:10.1007/s10198-017-0902-x.
195. Richardson, J., Khan, M. A., Iezzi, A., & Maxwell, A. (2015). Comparing and Explaining Differences in the Magnitude, Content, and Sensitivity of Utilities Predicted by the EQ-5D, SF-6D, HUI3, 15D, QWB, and AQoL-8D Multiattribute Utility Instruments. *Med Decis Making*, 35(3), 276-291, doi:10.1177/0272989x14543107.
196. White, I. R., & Carlin, J. B. (2010). Bias and Efficiency of Multiple Imputation Compared with Complete-Case Analysis for Missing Covariate Values. *Stat Med*, 29(28), 2920-2931, doi:10.1002/sim.3944.
197. Brazier, J. E., Harper, R., Jones, N. M., O'Cathain, A., Thomas, K. J., Usherwood, T., & Westlake, L. (1992). Validating the Sf-36 Health Survey Questionnaire: New Outcome Measure for Primary Care. *Bmj*, 305(6846), 160-164.
198. Jenkinson, C. (1991). Why Are We Weighting? A Critical Examination of the Use of Item Weights in a Health Status Measure. *Soc Sci Med*, 32(12), 1413-1416.
199. Walters, S. J., & Brazier, J. E. (2005). Comparison of the Minimally Important Difference for Two Health State Utility Measures: EQ-5D and SF-6D. *Quality of Life Research*, 14(6), 1523-1532, doi:10.1007/s11136-004-7713-0.
200. McClure, N. S., Sayah, F. A., Xie, F., Luo, N., & Johnson, J. A. (2017). Instrument-Defined Estimates of the Minimally Important Difference for EQ-5D-5L Index Scores. *Value Health*, 20(4), 644-650, doi:10.1016/j.jval.2016.11.015.
201. Alanne, S., Roine, R. P., Rasanen, P., Vainiola, T., & Sintonen, H. (2014). Estimating the Minimum Important Change in the 15D Scores. *Qual Life Res*, doi:10.1007/s11136-014-0787-4.
202. McGrath, C., & Bedi, R. (2004). Why Are We 'Weighting'? An Assessment of a Self-Weighting Approach to Measuring Oral Health-Related Quality of Life. *Community Dentistry and Oral Epidemiology*, 32(1), 19-24, doi:<http://10.1046/j.0301-5661.2003.00110.x>.
203. Trauer, T., & Mackinnon, A. (2001). Why Are We Weighting? The Role of Importance Ratings in Quality of Life Measurement. *Quality of Life Research*, 10(7), 579-585, doi:10.1023/A:1013159414364.
204. Wu, C. H., Chen, L., & Tsai, Y. M. (2009). Investigating Importance Weighting of Satisfaction Scores from a Formative Model with Partial Least Squares Analysis. *Social Indicators Research*, 90(3), 351-363, doi:<http://10.1007/s11205-008-9264-1>.
205. Kahneman, D., & Deaton, A. (2010). High Income Improves Evaluation of Life but Not Emotional Well-Being. *Proceedings of the National Academy of Sciences*, 107(38), 16489-16493, doi:10.1073/pnas.1011492107.

206. Brickman, P., & Campbell, D. T. (1971). Hedonic Relativism and Planning the Good Society. In M. H. Apley (Ed.), *Adaptation-Level Theory: A Symposium* (pp. 287-305): Academic Press.
207. Van Praag, B. (1971). The Welfare Function of Income in Belgium: An Empirical Investigation. *European Economic Review*, 2(3), 337-369, doi:[http://dx.doi.org/10.1016/0014-2921\(71\)90045-6](http://dx.doi.org/10.1016/0014-2921(71)90045-6).
208. Ryan, R. M., & Deci, E. L. (2001). On Happiness and Human Potentials: A Review of Research on Hedonic and Eudaimonic Well-Being. *Annu Rev Psychol*, 52, 141-166, doi:10.1146/annurev.psych.52.1.141.
209. Seligman, M. E. P. (2011). *Flourish : A Visionary New Understanding of Happiness and Well-Being*. New York: Free Press.
210. Helliwell, J. F., & Putman, R. D. (2004). The Social Context of Well-Being. *Philos Trans R Soc Lond B Biol Sci.*, 359(1449), 1435-1446, doi:10.1098/rstb.2004.1522.
211. Horesh, N., & Apter, A. (2006). Self-Disclosure, Depression, Anxiety, and Suicidal Behavior in Adolescent Psychiatric Inpatients. *Crisis*, 27(2), 66-71, doi:10.1027/0227-5910.27.2.66.
212. Stillman, T. F., Baumeister, R. F., Lambert, N. M., Crescioni, A. W., DeWall, C. N., & Fincham, F. D. (2009). Alone and without Purpose: Life Loses Meaning Following Social Exclusion. *Journal of experimental social psychology*, 45(4), 686-694.
213. Headey, B. (2008). The Set-Point Theory of Well-Being: Negative Results and Consequent Revisions. *Social Indicators Research*, 85(3), 389-403.
214. Costa, P. T., McCrae, R. R., & Zonderman, A. B. (1987). Environmental and Dispositional Influences on Well-Being: Longitudinal Follow-up of an American National Sample. *British Journal of Psychology*, 78(3), 299-306, doi:10.1111/j.2044-8295.1987.tb02248.x.
215. Johns, H., & Ormerod, P. (2007). Happiness, Economics and Public Policy. Institute of Economic Affairs, Research Monograph 62. Retrived from <https://iea.org.uk/publications/research/happiness-economics-and-public-policy>.
216. Baumeister, R. F., & Leary, M. R. (1995). The Need to Belong: Desire for Interpersonal Attachments as a Fundamental Human Motivation. *Psychol Bull*, 117(3), 497-529.
217. Kasser, T., & Ryan, R. M. (1996). Further Examining the American Dream: Differential Correlates of Intrinsic and Extrinsic Goals. *Personality and Social Psychology Bulletin*, 22(3), 280-287, doi:doi:10.1177/0146167296223006.
218. Easterlin, R. (2005). Building a Better Theory of Well-Being. In P. P. L. Bruni (Ed.), *Economics and Happiness: Framing the Analysis* (pp. 29-65). Oxford: Oxford University Press.
219. Berkman, L. F. (1983). The Assessment of Social Networks and Social Support in the Elderly. *J Am Geriatr Soc*, 31(12), 743-749.
220. Pietersma, S., De Vries, M., & Van Den Akker-Van Marle, M. E. (2014). Domains of Quality of Life: Results of a Three-Stage Delphi Consensus Procedure among Patients, Family of Patients, Clinicians, Scientists and the General Public. *Quality of Life Research*, 23(5), 1543-1556, doi:10.1007/s11136-013-0578-3.
221. de Vries, M., Emons, W. H. M., Plantinga, A., Pietersma, S., van den Hout, W. B., Stiggelbout, A. M., & Elske van den Akker-van Marle, M. (2016). Comprehensively Measuring Health-Related Subjective Well-Being: Dimensionality Analysis for Improved Outcome Assessment in Health Economics. *Value in Health*, 19(2), 167-175, doi:<http://dx.doi.org/10.1016/j.jval.2015.11.010>.

9 Papers 1-3

10 Appendices

Appendix 1: Visual analogue scale

Visual Analogue Scale (VAS)

Rate Your Health

The following question will ask you to think about your own health today and compare it with what we will define as 'Excellent Health'.

Excellent health is the **best possible health** you can imagine. You may have some health problems which, however slight, means that your health may be less than what is described as excellent in the box above.

*** Description of Excellent Health**

Physical Health

- No pain, discomfort or itching
- Perfect hearing, vision, speech
- Excellent strength, flexibility, movement, energy

Mental Health

- Very happy, enthusiastic, contented
- Never sad, depressed
- Confident, high self-worth

Social

- Excellent social and family relationships

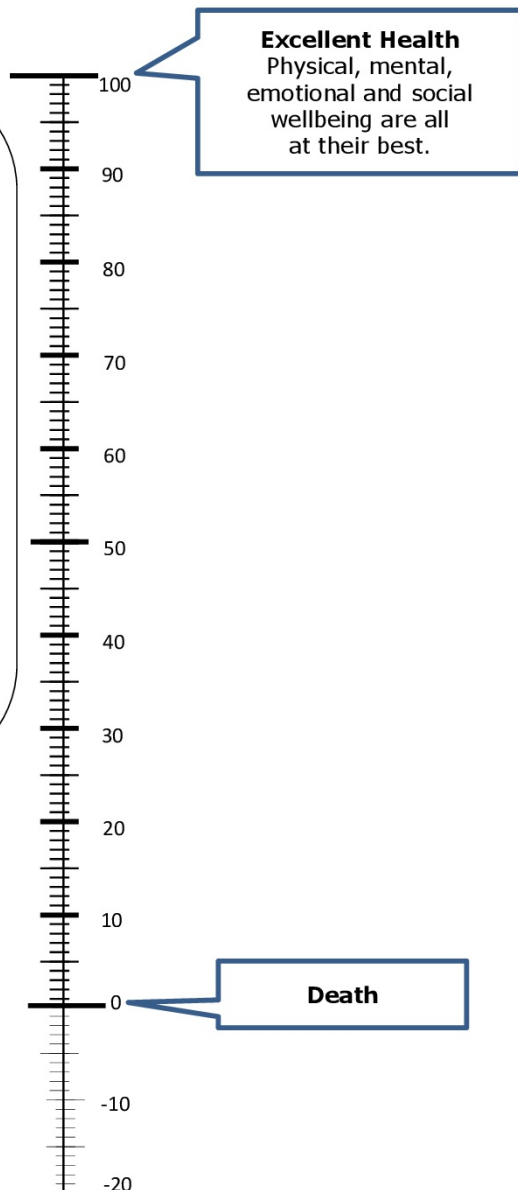

Please think about **your own state of health**.

How would you rate **your health state** on the scale shown?

Appendix-2: Health state utility (HSU) instruments used

SF-6D classification system (derived from SF-36)

Physical Functioning

- My health does not limit me in vigorous activities
- My health limits me a little in vigorous activities
- My health limits me a little in moderate activities
- My health limits me a lot in moderate activities
- My health limits me a little in bathing and dressing
- My health limits me a lot in bathing and dressing

Role limitations

- I have no problems with my work or other regular daily activities as a result of my physical health or any emotional problems
- I am limited in the kind of work or other activities as a result of my physical health
- I accomplish less than I would like as a result of emotional problems
- I am limited in the kind of work or other activities as a result of my physical health and accomplish less than I would like as a result of emotional problems

Social functioning

- My health limits my social activities none of the time
- My health limits my social activities a little of the time
- My health limits my social activities some of the time
- My health limits my social activities most of the time
- My health limits my social activities all of the time

Pain

- I have no pain
- I have pain but it does not interfere with my normal work (both outside the home and housework)
- I have pain that interferes with my normal work (both outside the home and housework) a little bit
- I have pain that interferes with my normal work (both outside the home and housework) moderately
- I have pain that interferes with my normal work (both outside the home and housework) quite a bit
- I have pain that interferes with my normal work (both outside the home and housework) extremely

Mental health

- I feel tense or downhearted and low none of the time
- I feel tense or downhearted and low a little of the time
- I feel tense or downhearted and low some of the time
- I feel tense or downhearted and low most of the time
- I feel tense or downhearted and low all of the time

Vitality

- I have a lot of energy all of the time
- I have a lot of energy most of the time
- I have a lot of energy some of the time
- I have a lot of energy a little of the time
- I have a lot of energy none of the time

HUI3 classification system (Please select the answer for each attribute that is correct for you)

Vision

- Able to see well enough to read ordinary newsprint and recognize a friend on the other side of the street, without glasses or contact lenses.
- Able to see well enough to read ordinary newsprint and recognize a friend on the other side of the street, but with glasses.
- Able to read ordinary newsprint with or without glasses but unable to recognize a friend on the other side of the street, even with glasses.
- Able to recognize a friend on the other side of the street with or without glasses but unable to read ordinary newsprint, even with glasses.
- Unable to read ordinary newsprint and unable to recognize a friend on the other side of the street, even with glasses.
- Unable to see at all.

Hearing

- Able to hear what is said in a group conversation with at least three other people, without a hearing aid.

- Able to hear what is said in a conversation with one other person in a quiet room without a hearing aid, but requires a hearing aid to hear what is said in a group conversation with at least three other people.
- Able to hear what is said in a conversation with one other person in a quiet room with a hearing aid, and able to hear what is said in a group conversation with at least three other people, with a hearing aid.
- Able to hear what is said in a conversation with one other person in a quiet room, without a hearing aid, but unable to hear what is said in a group conversation with at least three other people even with a hearing aid.
- Able to hear what is said in a conversation with one other person in a quiet room with a hearing aid, but unable to hear what is said in a group conversation with at least three other people even with a hearing aid.
- Unable to hear at all.

Speech

- Able to be understood completely when speaking with strangers or people who know me well.
- Able to be understood partially when speaking with strangers but able to be understood completely when speaking with people who know me well.
- Able to be understood partially when speaking with strangers or people who know me well.
- Unable to be understood when speaking with strangers but able to be understood partially by people who know me well.
- Unable to be understood when speaking to other people (or unable to speak at all).

Ambulation

- Able to walk around the neighbourhood without difficulty, and without walking equipment.
- Able to walk around the neighbourhood with difficulty, but does not require walking equipment or the help of another person.
- Able to walk around the neighbourhood with walking equipment, but without the help of another person.
- Able to walk only short distances with walking equipment, and requires a wheelchair to get around the neighbourhood.
- Unable to walk alone, even with walking equipment. Able to walk short distances with the help of another person, and requires a wheelchair to get around the neighbourhood.
- Cannot walk at all.

Dexterity

- Full use of two hands and ten fingers.
- Limitations in the use of hands or fingers, but does not require special tools or help of another person.
- Limitations in the use of hands or fingers, is independent with use of special tools (does not require the help of another person).
- Limitations in the use of hands or fingers, requires the help of another person for some tasks (not independent even with the use of special tools).
- Limitations in the use of hands or fingers, requires the help of another person for most tasks (not independent even with the use of special tools).
- Limitations in the use of hands or fingers, requires the help of another person for all tasks (not independent even with the use of special tools).

Emotion

- Happy and interested in life.
- Somewhat happy.
- Somewhat unhappy.
- Very unhappy.
- So unhappy that life is not worthwhile.

Cognition

- Able to remember most things, think clearly and solve day to day problems.
- Able to remember most things, but have a little difficulty when trying to think and solve day to day problems.
- Somewhat forgetful, but able to think clearly and solve day to day problems.
- Somewhat forgetful, and have a little difficulty when trying to think or solve day to day problems.
- Very forgetful, and have great difficulty when trying to think or solve day to day problems.
- Unable to remember anything at all, and unable to think or solve day to day problems.

Pain

- Free of pain and discomfort.
- Mild to moderate pain that prevents no activities.
- Moderate pain that prevents a few activities.
- Moderate to severe pain that prevents some activities.
- Severe pain that prevents most activities.

15D (Select the answer which best describes *your present health status*)

Mobility

- I am able to walk normally (without difficulty) indoors, outdoors and on stairs.
- I am able to walk without difficulty indoors, but outdoors and/or on stairs I have slight difficulties.
- I am able to walk without help indoors (with or without an appliance), but outdoors and/or on stairs only with considerable difficulty or with help from others.
- I am able to walk indoors only with help from others.
- I am completely bed-ridden and unable to move about.

Vision

- I see normally, i.e. I can read newspapers and TV text without difficulty (with or without glasses).
- I can read papers and/or TV text with slight difficulty (with or without glasses).
- I can read papers and/or TV text with considerable difficulty (with or without glasses).
- I cannot read papers or TV text either with glasses or without, but I can see enough to walk about without guidance.
- I cannot see enough to walk about without a guide, i.e. I am almost or completely blind.

Hearing

- I can hear normally, i.e. normal speech (with or without a hearing aid).
- I hear normal speech with a little difficulty.
- I hear normal speech with considerable difficulty; in conversation I need voices to be louder than normal.
- I hear even loud voices poorly; I am almost deaf.
- I am completely deaf.

Breathing

- I am able to breathe normally, i.e. with no shortness of breath or other breathing difficulty.
- I have shortness of breath during heavy work or sports, or when walking briskly on flat ground or slightly uphill.
- I have shortness of breath when walking on flat ground at the same speed as others my age.
- I get shortness of breath even after light activity, e.g. washing or dressing myself.
- I have breathing difficulties almost all the time, even when resting.

Sleeping

- I am able to sleep normally, i.e. I have no problems with sleeping
- I have slight problems with sleeping, e.g. difficulty in falling asleep, or sometimes waking at night.
- I have moderate problems with sleeping, e.g. disturbed sleep, or feeling I have not slept enough.
- I have great problems with sleeping, e.g. having to use sleeping pills often or routinely, or usually waking at night and/or too early in the morning.
- I suffer severe sleeplessness, e.g. sleep is almost impossible even with full use of sleeping pills, or staying awake most of the night.

Eating

- I am able to eat normally, i.e. with no help from others.
- I am able to eat by myself with minor difficulty (e.g. slowly, clumsily, shakily, or with special appliances).
- I need some help from another person in eating.
- I am unable to eat by myself at all, so I must be fed by another person.
- I am unable to eat at all, so I am fed either by tube or intravenously

Speech

- I am able to speak normally, i.e. clearly, audibly and fluently.
- I have slight speech difficulties, e.g. occasional fumbling for words, mumbling, or changes of pitch.
- I can make myself understood, but my speech is e.g. disjointed, faltering, stuttering or stammering.
- Most people have great difficulty understanding my speech.
- I can only make myself understood by gestures.

Elimination

- My bladder and bowel work normally and without problems.
- I have slight problems with my bladder and/or bowel function, e.g. difficulties with urination, or loose or hard bowels.
- I have marked problems with my bladder and/or bowel function, e.g. occasional 'accidents', or severe constipation or diarrhea.
- I have serious problems with my bladder and/or bowel function, e.g. routine 'accidents', or need of catheterization or enemas.
- I have no control over my bladder and/or bowel function.

Usual Activities

- I am able to perform my usual activities (e.g. employment, studying, housework, free-time activities) without difficulty.
- I am able to perform my usual activities slightly less effectively or with minor difficulty.
- I am able to perform my usual activities much less effectively, with considerable difficulty, or not completely.
- I can only manage a small proportion of my previously usual activities.
- I am unable to manage any of my previously usual activities.

Mental Function

- I am able to think clearly and logically, and my memory functions well
- I have slight difficulties in thinking clearly and logically, or my memory sometimes fails me.
- I have marked difficulties in thinking clearly and logically, or my memory is somewhat impaired.
- I have great difficulties in thinking clearly and logically, or my memory is seriously impaired.
- I am permanently confused and disoriented in place and time.

Discomfort and Symptoms

- I have no physical discomfort or symptoms, e.g. pain, ache, nausea, itching etc.
- I have mild physical discomfort or symptoms, e.g. pain, ache, nausea, itching etc
- I have marked physical discomfort or symptoms, e.g. pain, ache, nausea, itching etc.
- I have severe physical discomfort or symptoms, e.g. pain, ache, nausea, itching etc
- I have unbearable physical discomfort or symptoms, e.g. pain, ache, nausea, itching etc.

Depression

- I do not feel at all sad, melancholic or depressed.
- I feel slightly sad, melancholic or depressed.
- I feel moderately sad, melancholic or depressed.
- I feel very sad, melancholic or depressed.
- I feel extremely sad, melancholic or depressed.

Distress

- I do not feel at all anxious, stressed or nervous.
- I feel slightly anxious, stressed or nervous.
- I feel moderately anxious, stressed or nervous.
- I feel very anxious, stressed or nervous.
- I feel extremely anxious, stressed or nervous.

Vitality

- I feel healthy and energetic.
- I feel slightly weary, tired or feeble.
- I feel moderately weary, tired or feeble.
- I feel very weary, tired or feeble, almost exhausted.
- I feel extremely weary, tired or feeble, totally exhausted.

Sexual Activity

- My state of health has no adverse effect on my sexual activity.
- My state of health has a slight effect on my sexual activity.
- My state of health has a considerable effect on my sexual activity.
- My state of health makes sexual activity almost impossible.
- My state of health makes sexual activity impossible.

Appendix-3: Disease specific instruments used

Diabetes-39

During the past month how much was the quality of your life affected by: (place an X in a box between 1 and 7)

1. your diabetes medication schedule
2. worries about money matters
3. limited energy levels
4. following your doctor's prescribed treatment plan for diabetes
5. food restrictions required to control your diabetes
6. concerns about our future
7. other health problems besides diabetes
8. stress or pressure in your life
9. feelings of weakness
10. restrictions on how far you can walk
11. any daily exercises for your diabetes
12. loss or blurring of vision
13. not being able to do what you want
14. having diabetes
15. losing control of your blood sugar levels
16. other illnesses besides diabetes
17. testing your blood sugar levels
18. the time required to control your diabetes
19. the restrictions your diabetes places on your family and friends
20. being embarrassed because you have diabetes
21. diabetes interfering with your sex life
22. feeling depressed or low
23. problems with sexual functioning
24. getting your diabetes well controlled
25. complications from your diabetes
26. doing things that your family and friends don't do
27. keeping a record of your blood sugar levels
28. the need to eat at regular intervals
29. not being able to do housework or other jobs around the house
30. a decreased interest in sex
31. having to organise your daily life around diabetes
32. needing to rest often
33. problems in climbing stairs or walking up steps
34. having trouble caring for yourself (dressing, bathing, or using the toilet)
35. restless sleep
36. walking more slowly than others
37. being identifies as a diabetic
38. having diabetes interfere with your family life
39. diabetes in general

	Not affect						Extre mely
	1	2	3	4	5	6	7
1	1	2	3	4	5	6	7
2	1	2	3	4	5	6	7
3	1	2	3	4	5	6	7
4	1	2	3	4	5	6	7
5	1	2	3	4	5	6	7
6	1	2	3	4	5	6	7
7	1	2	3	4	5	6	7
8	1	2	3	4	5	6	7
9	1	2	3	4	5	6	7
10	1	2	3	4	5	6	7
11	1	2	3	4	5	6	7
12	1	2	3	4	5	6	7
13	1	2	3	4	5	6	7
14	1	2	3	4	5	6	7
15	1	2	3	4	5	6	7
16	1	2	3	4	5	6	7
17	1	2	3	4	5	6	7
18	1	2	3	4	5	6	7
19	1	2	3	4	5	6	7
20	1	2	3	4	5	6	7
21	1	2	3	4	5	6	7
22	1	2	3	4	5	6	7
23	1	2	3	4	5	6	7
24	1	2	3	4	5	6	7
25	1	2	3	4	5	6	7
26	1	2	3	4	5	6	7
27	1	2	3	4	5	6	7
28	1	2	3	4	5	6	7
29	1	2	3	4	5	6	7
30	1	2	3	4	5	6	7
31	1	2	3	4	5	6	7
32	1	2	3	4	5	6	7
33	1	2	3	4	5	6	7
34	1	2	3	4	5	6	7
35	1	2	3	4	5	6	7
36	1	2	3	4	5	6	7
37	1	2	3	4	5	6	7
38	1	2	3	4	5	6	7
39	1	2	3	4	5	6	7

K10 (These questions deal with the Past 4 weeks)

	All of the time	Most of the time	Some of the time	A little of the time	None of the time
1. In the past 4 weeks, about how often did you feel tired for no good reason?					
2. In the past 4 weeks, about how often did you feel nervous?					
3. In the past 4 weeks, about how often did you feel so nervous that nothing could calm you down?					
4. In the past 4 weeks, about how often did you feel hopeless?					
5. In the past 4 weeks, about how often did you feel restless or fidgety?					
6. In the past 4 weeks, about how often did you feel so restless that you could not sit still?					
7. In the past 4 weeks, about how often did you feel depressed?					
8. In the past 4 weeks, about how often did you feel that everything was an effort?					
9. In the past 4 weeks, about how often did you feel so sad that nothing could cheer you up?					
10. In the past 4 weeks, about how often did you feel worthless?					