

# **Isolation and Characterization of New Secondary Metabolites from the Arctic Bryozoans *Securiflustra securifrons* and *Dendrobeatia murrayana***

**Raja Priyanka Mary Michael Siranjeevi**

*A dissertation for the degree of Philosophiae Doctor – June 2019*

**Isolation and Characterization of New Secondary  
Metabolites from the Arctic marine Bryozoans *Securiflustra  
securifurans* and *Dendrobeatia murrayana***

---

Raja Priyanka Mary Michael Siranjeevi

## Summary

Bryozoans are colonial, filter feeding aquatic invertebrates known from the tropical to Polar Regions. Due to the sessile nature of bryozoans and lack of immune system, they have evolved the ability to produce secondary metabolites as a chemical defense, which is enabling them to protect themselves from predators and to compete for space and food in a competitive environment and adapt to extreme environment conditions. Secondary metabolites are characterized by high chemical diversity. The chemical diversity of marine bryozoans is under-investigated and identification of new chemical compounds from marine bryozoans are still limited. Nearly 250 compounds have been recorded until to date. The present study was focused on isolation and characterization of new compounds from Arctic marine bryozoans. The novel compounds were isolated by using two different approaches.

For bioassay-guided isolation, fractions of an extract of the Arctic bryozoan *Securiflustra securifrons* were screened for anticancer activity. The active fractions were analyzed by ultra-performance liquid chromatography high-resolution mass spectrometry (UPLC-HR-MS), and the elemental composition of the target compound was determined and dereplicated. The target compound was isolated from the aqueous extract of *S. securifrons* through mass-guided fractionation. The structure of the isolated compound, securidine A, was elucidated by 1D and 2D NMR spectroscopic techniques. Securidine A is a new  $\beta$ -phenylethylamine alkaloid. Securidine A was evaluated for its anticancer activity, and it did not show any significant cytotoxic effect. Furthermore, securidine A was tested in various bioassays including antibacterial, antidiabetic and the ability to inhibit the biofilm formation, but no bioactivity was observed.

Fractions of the organic extract of *S. securifrons* were also screened for antibacterial activity. The chemical analysis of the active fraction revealed that it contained several securamines along with securidine A. The securamines and their anticancer activity were reported earlier by our research group. The pure compounds securamines C, E, H, I and J were tested against G + and G - pathogenic bacteria and yeast strains, and their ability to inhibit biofilm formation was also studied. Among these, securamine H was active against *B. subtilis* and the mode of action studies revealed that securamine H reduced the metabolic activity of *B. subtilis* but no interference with bacterial intracellular metabolic processes were found. To address any synergistic interactions, the minor compound securamine H and the major compound securidine A were assayed together, but no such effect was observed.

A new secondary metabolite, dendrobeaniamine A was isolated from the Arctic bryozoan *Dendrobeatia murrayana* through chemistry-guided isolation. A chemical analysis of the organic crude extract of *D. murrayana* by using UPLC-HRMS with positive electrospray mode (ESI+) led to the isolation of lipophilic amino acid molecule, dendrobeaniamine A. The protonated elemental composition of the target compound was calculated and dereplicated. The structure was solved by various 1D and 2D NMR

spectroscopic methods. The isolated compound was an acyl amino acid, which consist of a C<sub>12</sub> fatty acid chain conjugated with the amino acid arginine. The bioactivity of dendrobeaniamine A was evaluated using cellular and biochemical assays, such as antimicrobial, anti-inflammatory and antioxidant activities, but no activity was found.

## Acknowledgement

This PhD work was carried out at the Centre for Research-based Innovation on Marine Bioactivities and Drug discovery (MabCent), Norwegian College of Fishery Science (NFH), UiT- The Arctic University of Norway during the period from June 2015 to June 2019. The work was funded by the University.

First and foremost, I would like to express my sincere gratitude to my main supervisor Prof. Dr. Espen Hansen and co-supervisor Prof. Dr. Jeanette H. Anderson for giving me this opportunity to pursue my doctoral research at Marbio. I genuinely appreciate the guidance, discussions and, help with writing manuscripts and thesis as well as their continuous support throughout my PhD period. Thank you very much for your motivation and patience.

I would like to thank Dr. John Isaksson and Dr. Kine Ø. Hansen for their excellent NMR work and their contributions in the manuscripts are highly appreciated. I extend my thanks to all co-authors for their significant work in the manuscripts.

I am very grateful to the Marine Biobank (Marbank) for accessing the samples of marine invertebrates for this PhD work. I am thankful to the University library, UiT for the publication fund and accessing reading materials for this study.

Further appreciation goes to the technical engineers at Marbio: Marte Albrigtsen and Kirsti Helland for their help with the bioassay experiments. Many thanks to my colleagues Ole, Yannik, Renate, Marte, Venke, Teppo, Chun, Richard, Lone for the friendly talk and nice gesture. In addition, I want to thank you all my co-workers in Marbio and Marbank for the support.

Finally, and most importantly, I would like to express my heartfelt gratitude to my parents, brothers and grandparents for their unconditional love, constant motivation and spiritual support given to me, without them, my academic journey would never have been possible. My special thanks extend to my significant other and family for their support and motivation.

## List of publications

This thesis based on two published papers I & II and one in revision (III) in *Marine Drugs* the following papers as referred to by roman numerals, in the text.

### Paper I

Priyanka Michael, Kine Ø. Hansen, Johan Isaksson, Jeanette H. Andersen, Espen Hansen (2017). A Novel Brominated Alkaloid Securidine A, Isolated from the Marine Bryozoan *Securiflustra securifrons* *Molecules*, **22**, 1-11.

### Paper II

Priyanka Michael, Espen Hansen, Johan Isaksson, Jeanette H. Andersen, Kine Ø. Hansen (2019). Dendrobeaniamine A, a new alkaloid from the Arctic marine bryozoan, *Dendrobeania murrayana*. *Natural Product Research*, 1-6.

### Paper III

Kine Ø. Hansen, Ida Kristine Ø. Hansen, Celine S. Richard, Priyanka Michael, Marte Jenssen, Jeanette H. Andersen, and Espen Hansen, Antimicrobial Activity of Securamines from the Bryozoan, *Securiflustra securifrons*.

In revision, submitted to *Marine Drugs*

## Table of Contents

<b>Summary</b> .....	i
<b>Acknowledgement</b> .....	iii
<b>List of publications</b> .....	iv
<b>1. Introduction</b> .....	1
1.1. Natural products .....	1
1.1.1. Structural diversity in natural products .....	2
1.1.2. Natural product derivatives .....	3
1.2. History of natural products from terrestrial to marine environment .....	3
1.3. NPs drugs - Challenges and prospects .....	6
1.4. Marine environment and biodiversity .....	8
1.4.1. Natural products from marine invertebrates .....	9
1.4.2. Natural products from the symbionts of marine invertebrates .....	10
1.5. FDA and EMA approved marine derived drugs .....	12
1.6. Natural products research on marine bryozoans .....	14
1.6.1. Marine bryozoans .....	16
1.6.2. Chemical defenses in marine bryozoans .....	19
1.6.3. Chemical diversity in marine bryozoans .....	19
1.7. Methodology .....	25
1.7.1. Extraction and sample preparation .....	25
1.7.2. Isolation by using prep-HPLC .....	26
1.7.3. Structure elucidation .....	27
1.7.4. Bioactivity profiling of isolated compounds .....	28
<b>2. Aim of the thesis</b> .....	30
<b>3. Summary of papers</b> .....	31
<b>4. General discussion</b> .....	34
4.1. Supply issues .....	35
4.2. Preparation of crude extract into fractions and bioactivity screening .....	36
4.3. Dereplication of crude extracts of <i>S. securifrons</i> .....	36
4.4. Bioactivity profiling of securidine A .....	37
4.5. Dereplication and bioactivity profiling of dendrobeaniamine A .....	39
4.6. Future perspective .....	41
<b>5. Concluding remarks</b> .....	41
<b>6. References</b> .....	42

## Paper I, II and III

# 1. Introduction

## 1.1. Natural products

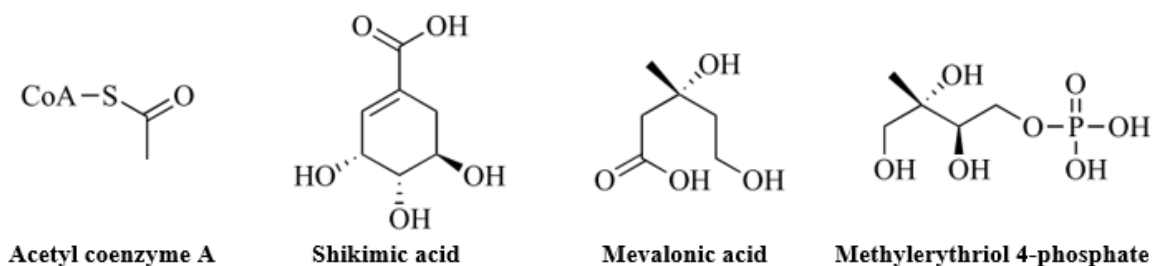
Natural products have long been a source of drug molecules in the treatment of diseases in humans, and natural products continue to provide structurally unique bioactive lead molecules for the development of new drugs [1, 2]. To date, over 60% of all approved drugs originate from natural products or are designed on the basis of natural product structures [3]. Natural products can be isolated from both terrestrial and marine environments. Approximately 250,000 new natural products have been described and many of them are used either as drugs or served as lead compounds [4].

Natural products (NPs) are small organic molecules, biosynthesized by living organisms such as plants, animals and microorganisms. NPs are often referred to as primary and secondary metabolites, in which primary metabolites are directly involved in the growth, development and reproduction of the producer organism and they are essential for the survival of the producer organism [5]. In contrast, secondary metabolites are not necessary for the fundamentals of life, but they increase chances of long-term survival and successful reproduction [6, 7]. The distribution of secondary metabolites may be limited and occurring only in some specific group or species. The chemical composition and abundance of secondary metabolites are differ largely between organisms and geographic areas [8]. Secondary metabolites may have a broad range of extrinsic functions in order to improve the survival of the organism in a competitive environment with complex predator interaction, competition for space and nutrients, prevention of biofouling and adoption to extreme environmental conditions [9]. Secondary metabolites can also act as social signaling molecules (pheromones and siderophores) for interspecies communication, mating, to attract or activate symbiotic organisms, for hunting (venom and toxins) and quorum sensing [5-7]. The functions of some secondary metabolites are known whereas, others are still under investigation. A comprehensive statistical data analysis indicated that nearly 15,000 marine secondary metabolites were discovered in the period of 1985-2012 and only 4196 secondary metabolites were considered as bioactive based on available bioassays [10]. It has been proven that, many secondary metabolites from plants, animals and microorganisms possess a wide range of biological activities such as antibacterial, antifungal, antiparasitic, antifouling, antiviral and antitumor activities, and a great variety of molecular structures, which can be potential for drug development and other biotechnological applications in the food and cosmetic industries [11-14].

The biosynthesis of secondary metabolites can be complex and is carried out through intermediates or end products of primary metabolic pathways. Many of the secondary metabolites including polyketides, peptides, alkaloids, terpenes, steroids and shikimic acid derivatives are derived from the intermediates such as Acetyl coenzyme A (acetyl-CoA), shikimic acid, mevalonic acid and methylerythritol phosphate biosynthetic pathways [15] (**Fig 1**). These intermediates are limited in number, but the formation of



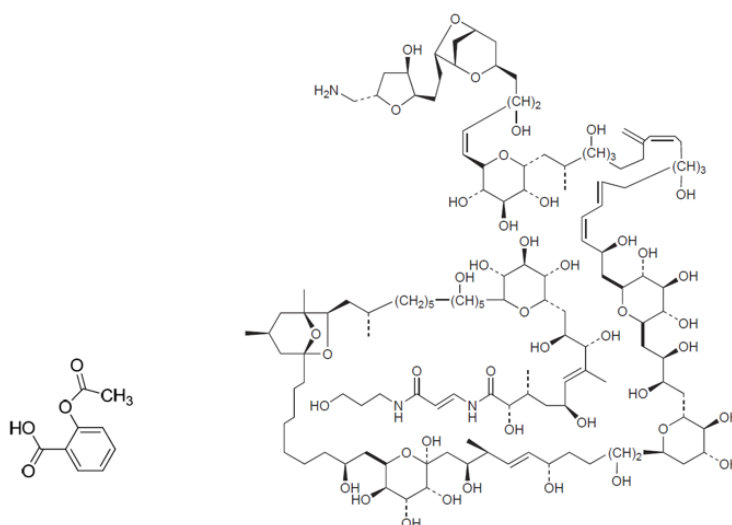
novel secondary metabolites are infinite due to the ways these intermediates can be combined and modified. In addition, the biosynthetic enzymes such as polyketide synthases, non-ribosomal peptide synthases and fatty acid synthases are also involved in the biosynthesis of unusual secondary metabolites [7, 16]. The biosynthetic pathway of a secondary metabolite may be activated as a response to environmental changes, such as presence or absence of nutrients, changes in pH or pressure and presence of pathogens or predators [17].



**Figure 1:** The four major building blocks of secondary metabolites

### 1.1.1. Structural diversity in natural products

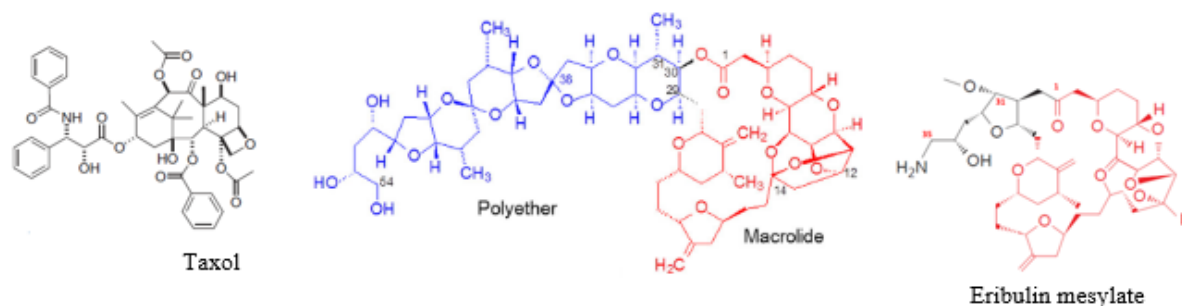
Natural products are characterized by their structural diversity [18]. They are represented by molecules and that are spanning from the simplest (*e.g.*: aspirin) to complex structures (*e.g.*: paclitaxel) [19] (**Fig 2**). NPs occupy a wide range of chemical space, in the sense that, NPs tend to have a higher number of chiral centers, higher number of hydrogen bond donors and acceptors, lower number of heavy atoms, lower molecular mass, higher diversity of ring systems and high polarity, which are not represented by synthetic compounds [20]. In addition, NPs tend to express more functional groups such as nitrogen-, sulphur- and halogen-containing groups, and a significantly higher number of oxygen atoms than synthetic compounds [21]. Moreover, the structures of NPs or secondary metabolites have evolved through biosynthesis by nature and are interacting efficiently with a wide variety of proteins. Therefore, many NPs act as potential lead compounds for drug discovery and development [22].



**Figure 2:** Chemical structure of simple natural product, Aspirin (*Left*) to complex natural product, Taxol (*Right*).

### 1.1.2. Natural product derivatives

Natural products often possess complex chemical structures and high biological activity compared with synthetic compounds. However, in order to improve the physio-chemical properties and reducing the complexity of the structure into simpler compound, NPs are chemically modified. The modifications are based on improving solubility and chemical stability, enhancing the bioactivity and selectivity, and modulating their drug ability with regard to absorption, distribution, metabolism, excretion and toxicity (ADMET). Such compounds are known as naturally derived compounds or natural product derivatives [18]. For example, an anticancer drug – paclitaxel, Taxol (**Fig 3**), isolated from the bark of the tree *Taxus brevifolia*, was modified chemically into a simpler structure to improve the efficacy and safety [23]. A complex marine natural product is halichondrin B (**Fig 3**), isolated from the marine sponges *Halichondria okadai* and *Lissodendoryx sp.* Halichondrin B is structurally complex, and it is a polyether macrolide (MW 1111.31) with *in vivo* and *in vitro* antitumor activity. Halichondrin B was totally synthesized for obtaining a sufficient amount and the structures of analogs were simplified [24, 25]. One of the analogs, eribulin mesylate (E7389) was a simplified ketone analog. E7389 showed the better activity than the parent compound due to the stability of the lactone in the single macrocyclic ring that is located on a right side of the parent molecule [26]. Eribulin mesylate (Halaven<sup>®</sup>) is currently in use for treating metastatic breast cancer [27]. In some cases, natural products are totally synthesized for economic reasons, environmental factors, and policy concerns. The yield of halichondrin B was very low and 12.5 mg of pure compound was obtained from 600 kg of sponges. Therefore, halichondrin B was totally synthesized [28].



**Figure 3:** Chemical structure of anticancer drugs, paclitaxel (Taxol) and marine derived natural product, halichondrin B. A part of a molecule, halichondrin B was modified (marked in red color) to replace an oxygen atom of the lactone linkage with a methylene group, and to introduce an amino group at the terminal of the side chain (marked in black color with red numbers in the structure of eribulin mesylate), in order to improve the efficiency of the compound.

### 1.2. History of natural products from terrestrial to marine environment

Historically, NPs have been derived from terrestrial plants to cure many human diseases. The medicinal use of plant derived natural products has been found in different cultures in history and is documented extensively [29]. The earliest medical document originates from the ancient Mesopotamia and, the well-known Egyptian pharmaceutical record *Ebers Papyrus*, and they both describe pharmacologically active

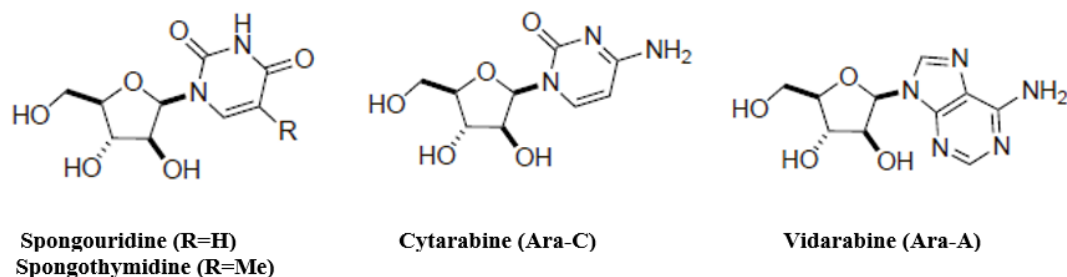
extracts from plants that were useful for the treatment of common cold, infections and inflammation [30]. The ancient Greek and the Roman physicians described the dosage and efficacy of plant-derived NPs, since some of the mixtures of herbal extracts contained harmful chemical substances [29]. Also in Asia, especially in the most primitive Chinese medicinal book *Prescriptions for Fifty-Two Diseases*, combinatorial drug formulae along with efficacies and synergies of natural medicines from plant extracts were described [31]. Until the eighteenth century, bioactive crude extracts or semi purified plant extracts were directly administered to humans for medical purposes [22]. In the early nineteenth century, a new era of medicine begun with the structural chemistry of pure compounds from crude extracts and administration of purified compounds in precise dosages [32]. In 1805, morphine (an analgesic agent) was isolated from the opium poppies of *Papaver somniferum* by Friedrich Sertürner, and this was the first alkaloid drug ever reported from the plant. In 1826, morphine was developed and commercialized by Emanuel Merck and considered as the first pure natural product. Further investigations of natural products in plant extracts led to the isolation and structure elucidation of several pure compounds that are still used for treatment of illnesses and diseases [33, 34]. Other well-known natural products are acetylsalicylic acid (aspirin) – an anti-inflammatory agent, isolated from willow bark, quinine and artemisinin – antimalarial agents, isolated from the bark of *Cinchona* tree and the leaves of the *Artemisia annua* plant respectively [29, 35, 36].

One of the most significant medical discoveries in the twentieth century was the first antibiotic penicillin G derived from the terrestrial fungi *Penicillium notatum* by Alexander Fleming in 1929 [37, 38]. This discovery eventually led to an extensive screening of microbes, particularly soil actinomycetes and fungi, resulting in several antibiotic compounds and immunosuppressant agents including tetracycline (*Streptomyces* species) and cephalosporin C (*Cephalosporium acremonium*), rapamycin (*Streptomyces* species) cyclosporine A (*Trichoderma* species) [39]. In addition, a cholesterol lowering agent, mevastatin and an anti-parasitic drug, ivermectin were also isolated from *Penicillium*, *Streptomyces* and *Aspergillus* species, respectively [40, 41]. Plants sources were also examined to identify anticancer drugs by the United States of America National Cancer Institute (NCI) during the 1970s, resulting in the discovery of the anticancer drugs taxol, camptothecin analogs from the bark of tree (*Camptotheca acuminata*) and the vinca alkaloid vincristine from the Madagascar periwinkle, *Catharanthus roseus* [2, 23, 42]. A study on the sources of drugs between 1981 to 2010 showed that nearly half of the new drugs (49%) were naturally derived compounds either semi-synthetic analogues of natural product or synthetic compounds based on natural-product pharmacophores. Many of them were antimicrobial agents (antibacterial, antiviral and anti-parasitic drugs) [20, 43, 44].

The Oceans cover almost three quarters of the Earth's surface, and they represent an abundant amount of biological diversity (census of marine life, 2000-2010) [45]. However, the number of traditional medicines from marine sources for treatment of human illnesses is low. The use of marine invertebrates

in medicinal applications were systematically described first by the Roman philosopher Plinius noted that, sponges with pure wine were used for the treatment of heart aches as well as all kinds of wounds, bone fractures, dropsy, stomach aches and infectious diseases [46]. In the fortieth century, a variety of iodine rich seaweed was used to treat low incidence of goiter in China and Japan. The red seaweeds *Chondrus crispus* and *Mastocarpus stellatus* were used for treating cough and cold, sore throat and bronchitis for several centuries in Ireland. In the 1940s, the first antibiotic cephalosporin C was isolated from the marine fungus *Acremonium chrysogenum* and characterized in 1961. The cephalosporin C was used as a lead for the development of the antibiotic class of cephalosporins and marketed as cephalothin in 1964 [47]. A significant marine natural product discovery was the identification of the unusual nucleosides spongouridine and spongouridine (Fig 4), which contained arabinose sugar. Both were obtained from the Caribbean sponge *Tethya crypta* by Bergmann and Feeney in 1951 [27]. These two compounds served as lead structures and eventually led to the development of the anticancer drug cytarabine (cytosine arabinoside - Ara-C) and the antiviral drug vidarabine (9-β-D- arabino furanosyl adenine - Ara-A). They are still in use today to treat acute myelocytic leukemia and non-Hodgkin's lymphoma and *Herpes simplex* infections respectively [28]. This discovery eventually led to the research in marine natural products chemistry and inspired researchers to search for drugs from marine organisms.

The systematic investigation of marine organisms for novel biologically active compounds begun in the late 1970s and revealed that many bioactive compounds were novel with unique chemical structure which have not been seen in terrestrial sources [48]. In the beginning, the collection of marine organisms was made primarily by skin diving and the samples were obtained from seashores and shallow waters. The development of reliable scuba diving, modern snorkeling techniques and the use of remotely operated vessels (ROVs) provided to access a wide range marine habitats and organisms, resulting in the characterization of nearly 10,000 marine natural products [2, 20, 49]. From 1990-2003, the number of MNPs increased to more than 14,800 according to the Marinlit database and more than 1000 MNPs have been reported each year since 2008 [27]. More than 50,000 molecules are to date reported in the Dictionary of Marine Natural Products [50]. In comparison with 200,000 terrestrial NPs, the number of MNPs is relatively smaller and the potential of marine environment is still under explored [2].

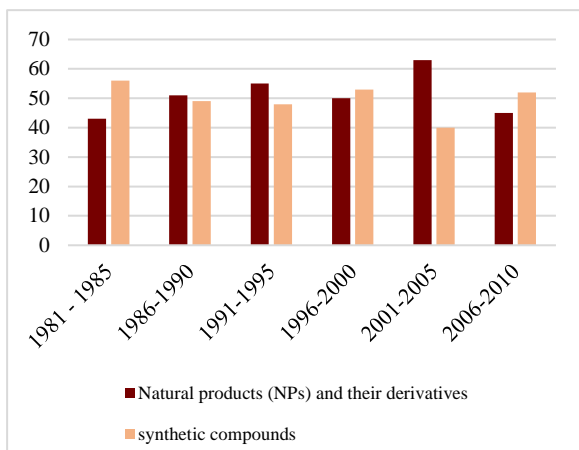


**Figure 4:** Chemical structures of the marine natural products spongouridine (R=H) and spongouridine (R=Me) and of the derived drugs cytarabine (Ara-C) and vidarabine (Ara-A).

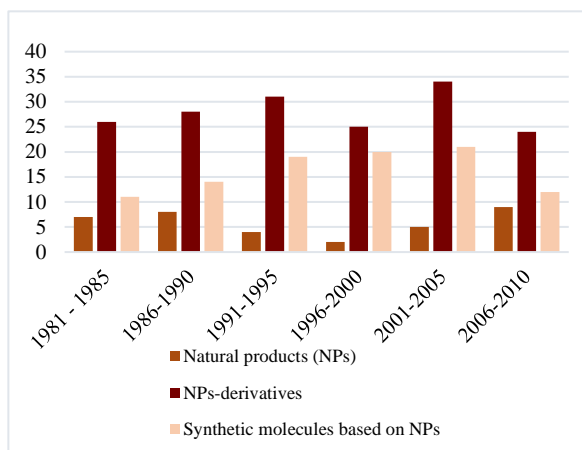
### 1.3. NPs drugs - Challenges and prospects

In the 1990s, the research on natural products significantly decreased, because natural products drug development in pharmaceutical companies was a time consuming and tedious process including identification and purification of NPs and the modification of complex molecular structure of NPs, which are often challenging to synthesis [44, 51]. Particularly, a high rate of rediscovery of known compounds was one of the major factors leading to the decreased interest from natural products pharmaceutical companies and academic research groups [52]. In addition, the complex mixture of crude extracts of NPs was not effectively detected by automated high-throughput bioassay screening, due to their solubility and low concentration of minor active metabolites masked by major metabolites in crude extracts [53]. Moreover, low abundance of pure compounds ( $10^{-5}$  to  $10^{-7}$  wet weight basis) from natural sources were not sufficient to analyze chemical and biological properties [54]. For example, a potent anticancer agent, dolastatin 10 was isolated from a sea hare, *Dolabella auricularia* and nearly two tons of *D. auricularia* was required to produce the first milligram of dolastatin 10, for testing its biological activity. This seasonal collection of sea hare from the island of Mauritius in the Indian Ocean took over ten years [28]. Meanwhile, the introduction of combinatorial chemistry along with high throughput screening (HTS) were mainly engaged on the drug development process instead of focusing on natural product research [44]. HTS allows for bioactivity screening of large number of small molecule compounds, which are chemically synthesized by combinatorial chemistry. Both bioactivity screening and synthesis of compounds can be done in short periods of time [44]. However, the chemical diversity in small molecule synthetic libraries developed by combinatorial chemistry was low, since the high number of compounds were produced from limited set of chemical scaffolds and these technologies delivered relatively few approved novel or new chemical compounds compared to NPs and their derivatives [55] (**Fig 5 and 6**).

A comparative analysis between the chemical diversity between NPs, marketed drugs and small molecule synthetic libraries revealed that, 40% of the studied NPs structures were not represented from the synthetic libraries [56]. Another comparative analysis of approved new chemical entities between 1981-2010 indicated that, the chemical diversity in NPs is higher than synthetic small molecule libraries due to the wide range of structural and physiochemical properties including larger molecular size, greater three-dimensional complexity, lower hydrophobicity and increased polarity and fewer aromatic rings [20, 57]. In addition, molecular complexity in NPs is one of the important features that differentiate them from synthetic compounds. Synthetic compounds are commonly flat and rigid molecules, whereas natural products generally contain more complex scaffolds, which is important in drug design. The structural complexity in NPs has been correlated for their biological activity and ability to interact with specific receptor sites on or within cells [58, 59]. Many NPs have also evolved to utilize transmembrane transporters that are able to let large, polar molecules cross biological membranes [60].



**Figure 5:** Approved NPs drugs and completely synthetic drugs represent equal share in the late 1980s and 2000. The trend of approved NPs drugs was increased in 2001-2005. In 2006-2010, it was relatively lesser NPs than synthetic molecules, which is correlating with the decommissioning of many natural product discovery programs in the pharmaceutical industry [20, 44].



**Figure 6:** Approved drugs between 1981-2010. The approved drugs based on natural product (NP), natural product-derivatives (ND), and synthetic compound based on natural product pharmacophore [20, 43].

Development of new methods in bioactivity screening and advances in analytical techniques are currently in use to address the challenges of natural products drug discovery. One of the approaches is dereplication, which refers to the rapid detection of known compound at the earliest stage of natural product drug discovery. Over 246,000 compounds have been reported from the nature, with approximately 4000 new compounds being added each year [61]. Dereplication strategies are the ability to match molecular features (spectroscopic data) of unknown NPs to the stored spectroscopic data in the commercial databases and it is implemented after initial screening of extracts or semi-purified extracts [62]. The dereplication process generally involves a combination of various advanced analytical methods also known as hyphenated techniques such as LC-MS, (U)HPLC-HRMS, HPLC-PDA-NMR, and these techniques often facilitate the search for known compounds through natural products commercial databases including, The Dictionary of Marine Natural Products, ChemSpider, SciFinder Scholar, AntiMarin and MarinLit [63].

**Bioactivity guided isolation:** The compound isolation from crude extracts has been prioritized based on the observed biological activity. In this method, the crude extract and fractions are tested for their potential biological activity in *in-vitro* bioassays such as biochemical and cell-based assays, before the isolation of target bioactive substances [64]. This type of bioactivity screening is often linked with HPLC fractionation, and after each fractionation step, the fractions are tested for bioactivity. When the chemical complexity of the fractions is reduced to a limited number of compounds, the fractions are analyzed by LC/UV with MS techniques, in order to identify known compounds. This process is known

as dereplication [65]. Bioassay guided fractionation is a tedious and time-consuming process, it requires significant amounts of crude extract and multiple fractionation steps, but automated fractionation in combination with high throughput screening can be cost effective. It is very important that the dereplication is efficient in order to avoid re-isolation and chemical characterization of previously reported bioactive compounds [66]. In some cases, the crude extract may have an activity that is lost after fractionation due to synergistic interaction between multiple compounds, in fact the synergy might account for better activity of mixtures than isolated compounds [67]. Therefore, a more efficient approach is necessary to overcome this limitation.

**Chemical guided isolation:** The main aim of this approach is to discover new NPs or NPs with novel chemical structures through the dereplication process. In this method, the molecular features of a target compound (unknown) is directly identified in crude extracts prior to detecting biological activity. The combination of LC (UHPLC) with UV diode array and HRMS allows detecting minor compounds present at low concentration ( $\mu\text{g}$  to  $\text{ng}$ ) in crude extract without prior isolation. More importantly, it provides structural information of the targeted compounds including the molecular weight with high mass accuracy and the measurement of isotopic pattern that is used for calculating elemental compositions (molecular formula). The advantage of chemical guided isolation is, to identify new compounds directly in extracts prior to bioassay and purification. It requires small (microgram) quantities of sample material [66, 68]. However, the isolated new chemical compounds from crude extracts may not be bioactive.

Advances in microbial genomics, in particular, genome sequencing or genome scanning provides an efficient way for the discovery new natural products biosynthetic gene clusters. For example, the whole genome sequencing of actinomycetes revealed that they possess 20 gene clusters, responsible for biosynthesis of different classes of secondary metabolites including polyketide synthase (PKS) and non-polyketide ribosomal synthase (NRPS) [69]. Another alternative approach is metagenomics that can also be used to discover new natural products from uncultivable marine microorganisms such as bacteria (< 1% known) and fungi (<5% known), that are potential producers of new secondary metabolites [51]. The biosynthetic genes (PKS) for the byrostatin family of antitumor compounds were identified in uncultivated symbiotic bacterium, *Candidatus Endobugula sertula* using a metagenomics approach [70]. Accessing unexplored habitats (Polar Regions and deep sea) and restricted group of micro and macroorganisms such as psychrophiles, thermophiles and acidophiles, can also provide novel compounds with unusual chemical structures [71].

#### **1.4. Marine environment and biodiversity**

The oceans cover more than 70% of the Earth's surface area and are the richest biosphere, containing 90% of all life forms in the planet. The biological diversity in the oceans is higher than terrestrial

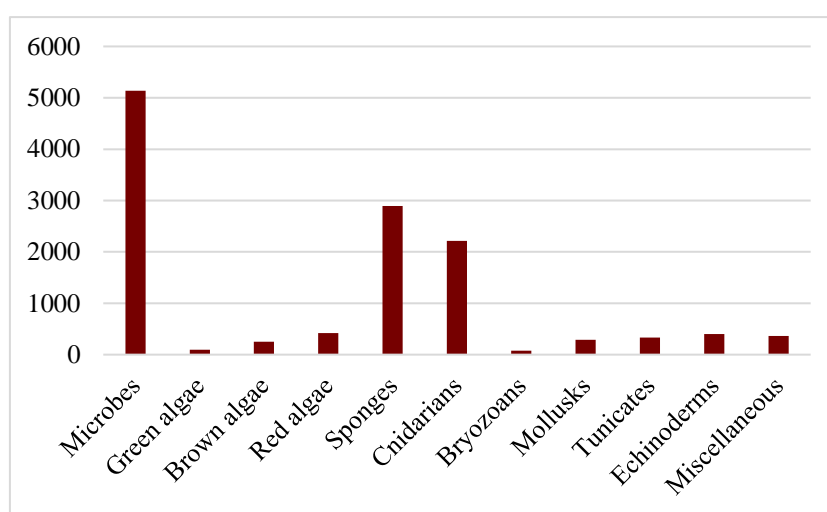
counterparts [45]. Of the 33 animal phyla reported to date, 32 are represented in the aquatic environment, and 15 of them are exclusively found in the oceans [72]. In addition, marine microorganisms are major constituents of the marine ecosystem and actively participate in biological processes. The microbial diversity in marine environment is enormous and it is estimated that sea water contains viruses at  $10^7$  pfu/ml, bacteria at  $10^6$  cfu/ml, fungi at  $10^3$  cfu/ml and microalgae at  $10^3$  cell/ml and marine sediments contain microorganism at  $10^9$  cfu/ml [73]. The abundance of marine biodiversity provides a potential reservoir of bioactive natural products, which contains structurally diverse chemical compounds with unusual combinations of functional groups including halogenated compounds especially bromine and, chlorine and sulfated compounds that are not found in terrestrial organisms [74-76]. A large array of chemical diversity in marine secondary metabolites not only depends on biodiversity, it depends on geographical area as well. The marine organisms can be found from the tropical to polar waters and shallow to deep waters including benthic habitats and hydrothermal vents [77]. The living conditions of marine plants, animals and microbes are extremely different compare to terrestrial species with regard to environmental factors such as light, temperature, salinity, pressure, water current, dissolved oxygen content, pH and nutrient concentration [78-80]. These diverse habitats and properties might interfere or modify the biosynthetic pathways in marine organisms, resulting in the production of biologically active secondary metabolites such as terpenoids, alkaloids, polyketides, peptides, with a variety of unusual structures [81]. Moreover, marine organisms are catalyzing biochemical reactions with enzymes. Halophilic marine microbes possess many hydrolytic enzymes that are capable of functioning under conditions that lead to precipitation and denaturation of protein. A comparative analysis showed that natural products from marine species are superior to natural products from terrestrial in terms of chemical novelty. This study showed that 71% of the chemical scaffolds in the dictionary of marine natural products were exclusively found in marine organisms [58].

#### **1.4.1. Natural products from marine invertebrates**

Marine natural products have primarily been isolated from the marine invertebrate phyla Porifera, Echinodermata, Mollusca, Cnidaria, Bryozoa and sub phylum of Chordata –Tunicata [77]. A statistical analysis of marine natural products data from 2000 to 2017 estimated that approximately 60% of MNPs are isolated from marine invertebrates alone (**Fig 7**), and that MNPs exhibited a higher rate of bioactivity compared to NPs derived from terrestrial organisms [82]. Many marine invertebrates are sessile and soft-bodied animals, which are thriving within complex ecosystems [83]. Due to their sessile nature and absence of complex immune system, these organisms have evolved to develop chemical defenses, also known as NPs, to better their chances of survival. This includes NPs that deter predators or paralyze the prey, inhibit pathogens and fouling organisms on their surface and protection from UV radiation [84, 85]. The chemical defenses in marine invertebrates against predators has been proven in several studies [86]. One example is the conotoxins. Conotoxins are cyclic peptides, isolated from the fish hunting cone



snail, *Conus magus*. The conotoxins serve to immobilize the prey of the cone snail by targeting different voltage-gated ion channels (Na<sup>+</sup> and K<sup>+</sup>). The conotoxin derivative MVIIA is currently used as an analgesic drug and it is the first analgesic drug from a marine source. This compound proved to be 1000 times more active than morphine, which was derived from a terrestrial plant [32]. Many marine natural products isolated from marine invertebrates are extremely potent by means of bioactivity, probably because the compounds are rapidly diluted into the seawater. The potency of these compounds enables them to interact their biological target with high biochemical specificity [87]. These biologically active molecules have drug like properties, and they are capable of orally active due to relatively low lipophilicity. These bioactive natural products provide potential leads for pharmaceuticals (*e.g.* anti-infective agents) and other industrial (*e.g.* anti-fouling agents) applications [88, 89].



**Figure 7:** Total number of new compounds isolated from different marine sources over the last ten years

#### 1.4.2. Natural products from the symbionts of marine invertebrates

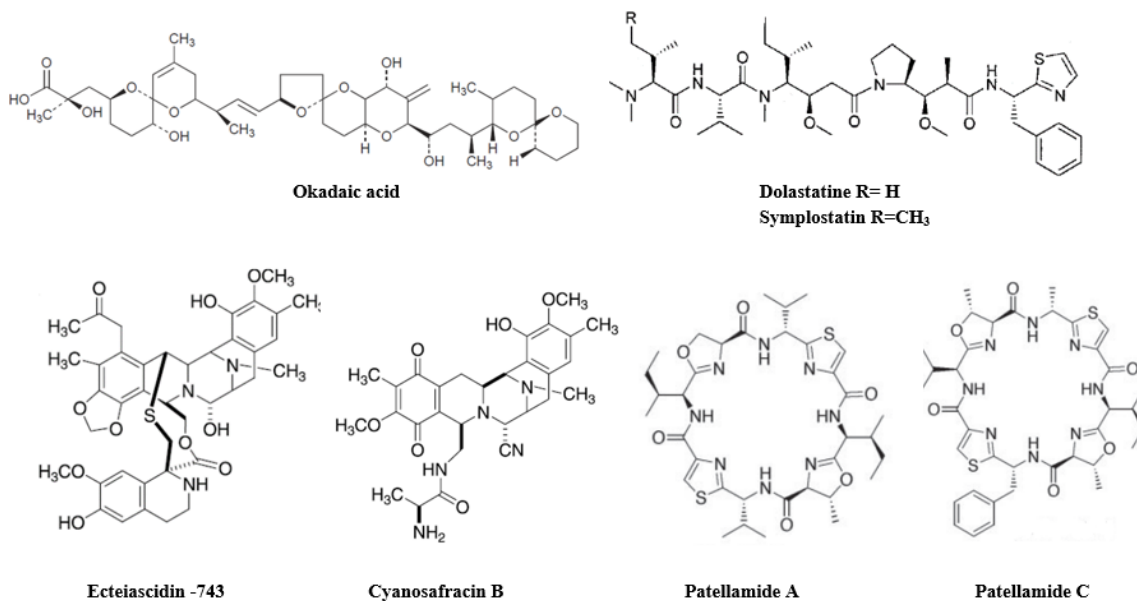
Numerous MNPs isolated from marine invertebrates, are structurally similar to marine microbial secondary metabolites, suggesting that, the microorganisms are possibly involved in the biosynthesis of the natural products [90, 91]. Marine invertebrates live in close association with microorganisms such as bacteria, fungi and cyanobacteria, which can be symbiotic or merely commensal or mutualistic [92]. The abundance of microbial diversity and the number of microbes in marine invertebrates may exceed than in seawater. In cnidarians for instance, the mucus of corals may contain 100-1000 times more microorganisms than the surrounding seawater [93, 94]. The microbiome of marine invertebrates reside either on the surface (epibionts) or an internal space (holobionts) of their host, also known as endosymbionts and they may contribute up to 40-60% of biomass [95, 96]. The associated microbes are possibly the true producers of many ‘invertebrate metabolites’ or ‘invertebrate NPs’ [97].

Microbial symbiosis with bacteria, archaea and unicellular eukaryotes (dinoflagellates) have been described for marine invertebrates including sponges, tunicates, mollusks corals and bryozoans. The

symbiosis is mainly based on small molecules, produced by microbes. These symbiotic microorganisms constantly involve within their animal host environment by exchanging nutritional molecules and molecules that can help the host to resist the pathogens and parasites, while others are quorum sensing molecules that establish its colonization within their host [95]. For example, the cyanobacterial symbiont, *Prochloron didemni* interacts with the host marine invertebrate ascidian, *Lissoclinum patella* for nutritional exchange. The cyanobacteria *Prochloron* spp. provide food by photosynthesis to their host and fixates the carbon, which is necessary for the host growth and in return, the cyanobacteria consume and recycle nitrogen from the host. These small molecules are possibly involved in the biosynthesis of defensive chemicals of their host [98]. The cytotoxic secondary metabolites patellamides were isolated from the marine invertebrate, ascidian *L. patella* [99]. However, the compound patellamide is possibly produced by one of the *Prochloron* species, *P. didemni*. A genome sequence analysis of the symbionts of ascidians revealed that *Prochloron* spp. synthesize patellamides by a ribosomal pathway [98, 100].

The marine natural product okadaic acid is a polycyclic polyether and it is a selective inhibitor of serine/threonine protein phosphatases. Okadaic acid is used as a research tool, as it is a potent probe for studying various molecular, cellular and biochemical mechanisms of neurotoxicity (*e.g.*: Alzheimer diseases) [101, 102]. Okadaic acid was originally isolated from the marine sponges, *Halichondria okadae* and *H. melanodocia*. However, it was later shown to be produced by the sponge-associated dinoflagellates *Prorocentrum* sp. and *Dinophysis* sp. [103-106]. Okadaic acid is a polyketide and the structure is closely related to another shellfish toxin, brevetoxin, which is produced by the dinoflagellate, *Karenia brevis* [78].

Another example of the microbial origin of a MNP is the antitumor agent, dolastatin 10, originally isolated from the marine mollusk *Dolabella auricularia*. A synthetic truncated analogue of dolastatin 10, monomethyl auristatin E, is currently used as a part of the antibody conjugated drug marketed as Adcetris [27]. Dolastatin 10 was later found to be a cyanobacterial metabolite, produced by a *Symploca* sp. (strain no. VP642), and that the cyanobacterium is a dietary source of *D. auricularia* [107, 108]. A close examination of the structural features of the cytotoxic compound Ecteinascidin – 743 (ET-743), isolated from the tunicate *Ecteinascidia turbinata*, reveals that this compound bears a close resemblance to the antibiotic compound safracin B produced by *Pseudomonas fluorescens*, suggesting that ET-743 might be of bacterial origin [109]. This was confirmed by a metagenomics study where, the complete genome of the ET-743 producer is the gammabacterium *Candidatus Endoecteinascidia frumentensis* (*E. frumentensis*) [110, 111]. *Candidatus E. frumentensis* is an endosymbiont of the tunicate *E. turbinata* and it is likely a species-specific endosymbiont, since this compound is not identified in any other marine invertebrates [111, 112].



**Figure 8:** Marine natural products biosynthesized by microbial symbionts, isolated from marine invertebrates.

## 1.5. FDA and EMA approved marine derived drugs

There are currently nine marine derived drugs approved by the Food and Drug Administration (FDA) and the European Medicines Agency (EMA), 21 are in clinical trial phase III, and many more are in clinical trial phase I and II. The approved drugs are represented almost each of the marine chemical classes such as alkaloid, peptide, polyketide and polysaccharide. Chemical structures of approved drugs can be seen in **Fig 9**.

Cytarabine and vidarabine were the first marine derived drugs and, both are synthetic pyrimidine and purine nucleoside derivatives of spongothymidine and spongouridine, which were isolated from the Caribbean sponge *Tethya crypta*. Cytarabine (trade name Cytosar-U) can be chemically synthesized or produced by heterologous expression by the bacterium *Streptomyces griseus*. It was approved by the FDA in 1969 for the treatment of non-Hodgkin's lymphoma, myeloid and myelocytic leukaemia, and is still being in clinical use. Vidarabine (Vira) was approved by FDA in 1976 as an antiviral drug against *Herpes viruses* and poxviruses. However, the viral strains developed resistance to vidarabine, and it was discontinued as an antiviral drug. Presently, vidarabine is only used for ophthalmologic applications [28]. Ziconotide was the first marine derived analgesic agent for the treatment of severe chronic pain associated with cancer and spinal cord injury. It selectively targets N-type voltage-sensitive calcium channels, inhibiting the activity of a subset of neurons including pain-sensing primary nociceptors. Ziconotide is the synthetic form of  $\omega$ -conotoxin peptide MVIIA, which is a peptide composed of 25 amino acid residues with three sulfide bonds. Ziconotide was approved by the FDA in 2004 and by the EMEA in 2005 under the trade name Prialt. Ziconotide was discovered from the toxin of the cone

snail *Conus magus* in 1982 and was synthesized in 1987. Ziconitide is an unmodified marine natural product [113].

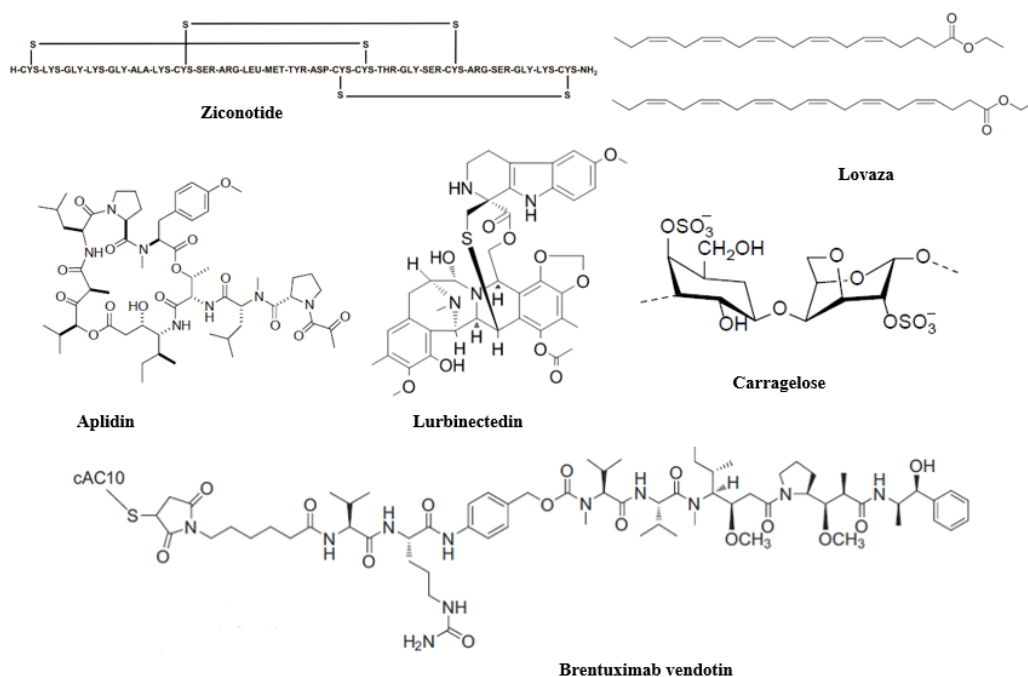
The second anticancer drug, Ecteinascidin-743 or trabectedin, is a tetrahydroisoquinoline alkaloid, containing three fused tetrahydroisoquinoline rings, eight rings including one 10-membered heterocyclic ring containing a cysteine residue and seven chiral centers. ET-743 was produced by semi-synthesis from the antimicrobial product cyanosafraicin B, which was obtained by fermentation of the bacteria *Pseudomonas fluorescens*, to overcome the supply issue of ectinascidine 743. ET-743 is also known as Yondelis and was approved by EMEA in 2007 for treatment of refractory advanced soft-tissue sarcomas and subsequently in 2009 it was approved in the EU for the treatment of relapsed ovarian cancer. Trabectedin binds to the DNA minor groove causing DNA damage and interferes with the cell division and the gene transcription processes and DNA repair machinery [114].

Another anticancer compound, eribulin mesylate, is a simplified ketone analogue of halichondrin B isolated from the marine sponges in 1987. The total synthesis was achieved in 1992 to solve the supply problem. The eribulin mesylate trade name is Halaven, and gained approval from FDA in 2010 and EMEA in 2011 for treating metastatic breast cancer. Eribulin mesylate inhibits the growth phase of microtubules, without affecting microtubule-shortening phase, and this leads to disruption of mitotic spindles and cell cycle arrest [24]. The antineoplastic drug, brentuximab vedotin is a derivative of the potent cytotoxic linear peptide dolastatin 10, which was isolated from the marine sea hare *Dolabella auricularia* in 1972. Dolastatin 10 can be produced by the cyanobacteria *Symploca hydroides* (new name - *Caldora penicillata*) and the total synthesis was achieved in 1987. The synthetic form of dolastatin 10 is a monomethyl auristatin E (MMAE) analog that combined to tumor specific antibody anti-CD30 antibody, forming antibody-drug conjugates in order to improve efficiency and reduced cytotoxicity. The antibody-drug conjugates, binds to tubulin in CD30 and tumor cells and disrupt the microtubule network. Brentuximab vendotin was approved by FDA in 2011 for the treatment of relapsed and refractory Hodgkin's lymphoma and anaplastic large cell lymphoma and is marketed as Adcetris [108].

The trabectedin analog, lurbinectedin or Zepsyre, is a synthetically derived anticancer agent. Lurbinectedin has been granted orphan drug status in 2019 by EMEA for the treatment of small cell lung cancer [115]. The latest marine derived antiproliferative agent, Plitedepsin was approved by Australia Therapeutic Good Administration (ATGA) in January 2019 for the treatment of relapsed and refractory multiple myeloma in combination with the corticosteroid medication dexamethasone. Plitedepsin is a cyclic peptide isolated from a Mediterranean tunicate *Aplidium albicans* in 1991. It is a synthetic derivative of didemnin B and was synthesized in 2000. Plitedepsin binds a specific protein (eEF1A2), which is overexpressed in cancer cells and blocks its function, which leads to protein aggregation and disrupt them by cell death. Plitedepsin is commercialized under the trade name Aplidin

[115]. Lovaza is an antihyperlipidemic drug, which normalize and control the triglyceride level in the human blood, and it was approved in 2014 by FDA and EMA. Lovaza is produced through esterification of the natural fatty acids eicosapentaenoic acid (EPA) and docosahexaenoic acid (DHA). Both EPA and DHA are polyunsaturated fatty acids (PUFAs), mainly extracted from fish. Both are used as omega-3 dietary supplements and act as inhibitors of thrombocyte aggregation and protection of cognitive functions in aging. Lovaza inhibits the synthesis of triglycerides and increases peroximal beta-oxidation of fatty acids in the liver [116] (**Fig 9**).

A final example of marine derived drugs is the Carragelose, derived from the Carrageenan. Carrageenan is a high molecular weight polysaccharide and it belongs to a family of linear sulfated polysaccharides. It is extracted from edible red seaweeds mainly *Chondrus crispus* and *Rhodophyceae sp.* Iota-carrageenan is a sub group of carrageenan, marketed as Carragelose in 2014. Carragelose is an antiviral nasal spray and it is proven to be a clinically effective treatment of early symptoms of common cold viral infections of the upper respiratory tract. Carragelose sold as an over-the counter (OTC) drug that acts by forming a protective layer in the nasal cavity against respiratory viruses [117].

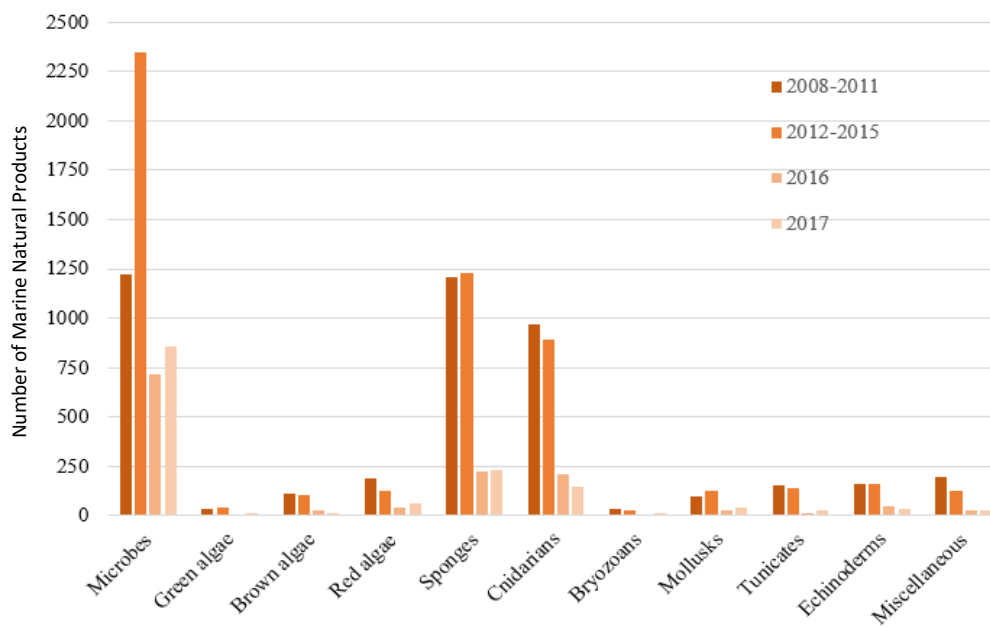


**Figure 9:** Commercially available marine derived drugs

## 1.6. Natural products research on marine bryozoans

The majority of MNPs has been isolated from marine invertebrate phyla including Porifera, Cnidaria, Echinodermata and Mollusca. NPs research on the phylum Bryozoa is limited and the bryozoans are still an underexploited resource. Since 1986, all structurally elucidated and published MNPs have been annually reviewed in the journal *Natural Product Reports* as the series *Marine Natural Products*. Over the last ten years (2008 to 2018), these reviews contained 9301 citations of 10,044 compounds from

marine sources such as invertebrates, phytoplankton, green, brown and red algae, diatoms, mangroves and other intertidal plants and microorganisms (**Fig 10**). Among the 9301 citations, only about 45 studies focused on marine bryozoans, and about 80 compounds were described. Over 8000 bryozoan species are known, and a total of approximately 250 new secondary metabolites have been isolated and characterized so far from about 50 species of marine bryozoans. In addition, about 100 studies have recorded on the isolation and structure elucidation of bryozoan secondary metabolites [118-128].



**Figure 10:** Number of marine natural products derived from bryozoans for last ten years (2008 -2018).

The reason for the limited number of studies on NPs research in marine bryozoans is possibly the taxonomic difficulties with the phylum that bryozoans might resemble organisms belonging to other phyla such as anthozoa or endoprozoa. In addition to that, bryozoans are often mistaken for marine plants or seaweeds [129]. The examination of large numbers of small colonies is not easy and it is laborious and time consuming. It is also difficult to obtain sufficient biomass for natural product research because many bryozoan have encrusted, erected and foliosed growth forms and the collection of larger quantities of biomass have permitted the isolation of small amount of secondary metabolites. For example, 13 tons of the marine bryozoan *Bugula neritina* (erected form of bryozoan) were harvested to yield only 18 g of pure bryostatin I, which was used for anticancer evaluation in phase I clinical trials [28, 130]. Accessibility of marine bryozoans might be another possible reason, since half of the marine bryozoans have habitats deeper than 40 m and about 30% of the species are found below 700 m in depth. In order to acquire species diversity of marine bryozoans, dredges or trawls must be engaged along with SCUBA diving and those operations are expensive [129, 131].

The increase in discovery of new MNPs has significantly declined due to high rates of rediscovery of known compounds and limited access to new biological sources [132]. This is a particular concern

because the emergence of drug resistance has serious implications for the prevention and treatment of diseases [133]. Therefore, searching for new chemical entities with novel structures from underexplored areas such as Arctic and Antarctic and underexplored biological sources are necessary. Thus, the discovery of new MNPs can potentially provide new and improved therapeutics for human illnesses, along with other innovative products for other industrial activities such as nutraceuticals and biotechnology applications [77].

Coldwater marine organism or psychrophiles are found in temperate and polar deep waters with temperatures ranging from -2 °C to + 4 °C. This includes the tropical deep-sea, where the temperature is nearly constant 4 °C as well as Antarctica, Canadian maritime, the Northern Sea of Japan and the North Sea 60 °N latitude [71]. Diverse and highly bioactive compounds have been isolated from the different sources of cold-water marine organisms including microbes and marine invertebrates such as sponges, cnidarians, tunicates and bryozoans. A marine bacterium, *Bacillus* sp., isolated from the sea mud near the Arctic pole, produces the new cyclic lipopeptides, mixirins A-C. These compounds displayed significant cytotoxicity against human colon tumor cell line (HCT-116) [134]. The brominated tryptophan derivatives, eusynstyelamides were isolated from the cold-water bryozoan, *Tegella cf. spitzbergenesis*. The eusynstyelamides exhibited antibacterial activity against Gram- positive (*S. aureus*) and Gram-negative (*E. coli*) bacteria [135].

### 1.6.1. Marine bryozoans

Bryozoans are aquatic invertebrates, belong to a phylum Bryozoa, otherwise known as Ectoprocta or Polyzoa (colonies of many individuals). Until 1831, bryozoans were misclassified as corals or hydroids, because they all have a moss-like appearance and encrusting formations. Thus, bryozoans are commonly called as ‘moss animals’ or ‘sea mats’. The name “Bryozoa” was coined by Christian Gottfried Ehrenberg, he described the presence of separate mouth and anus openings in bryozoans which, distinguished them from those animals that lacked this complex feature (i.e “Anthozoa”). In 1869, Hinrich Nitsche discovered another group of animals ‘Endoprocta’ that was similar to the phylum Bryozoa. Although both share a similar filter feeding mechanism, they possess a different internal anatomy. The position of the anus, either inside or outside the ring of tentacles (lophophore), is the main differentiating feature. However, the phylum Bryozoa is still widely referred to as Ectoprocta [136-138].

**Diversity:** The phylum Bryozoa is divided into three classes based on the structure of the zooid exoskeletons and the colony organization. The three classes consists of four orders, 187 families and 808 genera and currently more than 6000 species have been described as living forms [139]. The class Phylactolaemata contain exclusively freshwater bryozoans with non-calcified colonies and it contain the order Plumatellida with six families and about 90 representative species. The oldest class, Stenolaemata, is entirely marine and it comprises four orders. The only existing order is Cyclostomata

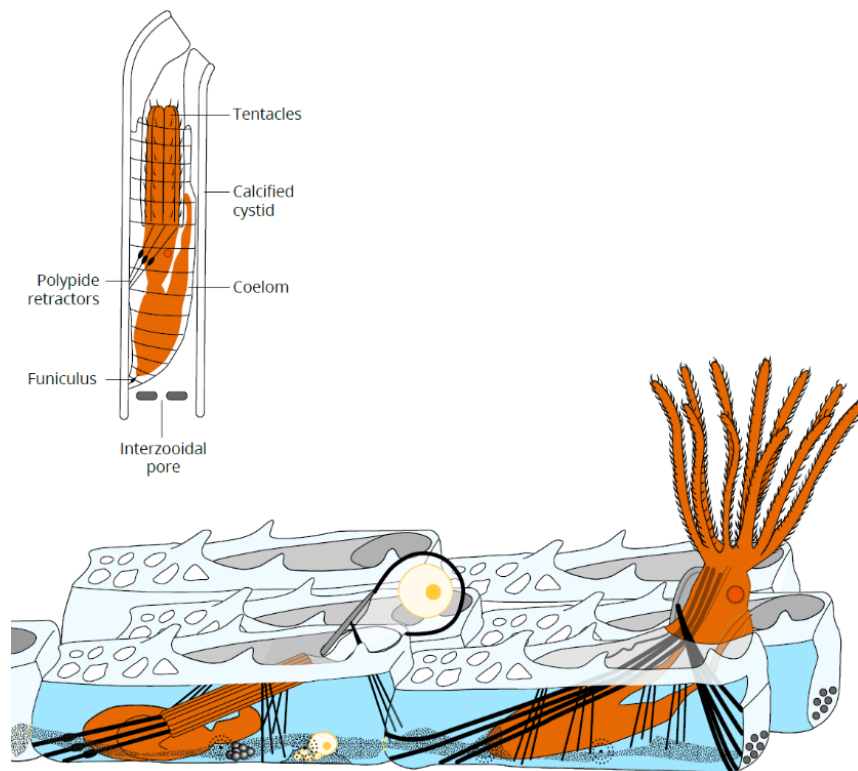
whereas the three other are extinct. The order Cyclostomata is characterized by calcified exoskeleton colonies with cylindrical or tube shaped zooids. The largest class, Gymnolaemata, is predominately found in the marine environment. It contains two orders, Ctenostomata, which have gelatinous colonies rather than calcified body walls and approximately 320 representative species. The largest and most successful order is Cheilostomata, which is exclusively found in the marine environment. The colonies of cheilostome bryozoans are composed of box shaped zooid and reinforced with calcium carbonate exoskeleton. Cheilostomata consists of 4921 living species. To date, the number of fossil species of bryozoans are higher than that of existing species, and a total of 15,000 species have been recorded [137, 140-142].

**Habitat and abundance:** Bryozoans are benthic, sessile colony forming invertebrates. These colonial invertebrates are predominantly found in the marine environment, and they are living from the intertidal zone down to the Deep Ocean. Bryozoans are widely distributed from polar to tropical waters, and they can also be found in fresh and brackish waters. The basal body portion of the bryozoan colony (Zoarium) is firmly attached to rocky substrates, seashells, coral reefs, hydroids, kelps, seaweeds. They are able to colonize artificial substrates such as pipes, boats or ship hulls, which is then referred to as biofouling. The bryozoan colonies develop in different forms, depending on the respective environment. The patterns or forms are branched, lobed, tuft, foliaceous, encrusting formation and appearing to be rigid or flexible. The colony size can vary from few millimeters to several decimeters. Large colonies of bryozoans may provide food, habitat and nursery ground for many micro and macro organisms, including bacteria, algae, diatoms, polychaets, hydroids, sponges, arthropods, larvae of other invertebrates and fishes [140, 143-147].

**Basic body plan:** Bryozoan colonies are composed of many tiny individuals or units called 'zooids'. Thus, the phylum Bryozoa is also known as polyzoa. The zooids are genetically and morphologically identical and polymorphic in nature, and the size range is approximately 0.5 mm to 1mm in length. The growth of zooid size depends on the environmental factors such as temperature and salinity [144, 148]. The zooids are interconnected to the neighboring zooids through inter zooidal pores or communicating pore and each zooid is separated by body wall that secretes chitinous or gelatinous or calcified skeleton material (zoecium). The zooids in bryozoan colonies have two different types of zooids. The basic units of autozooids are responsible for feeding for the entire colony and heterozooids are polymorphic and non-feeding zooids. These zooids have different functions such as strengthening of the colony (kenozooids- the zooids are greatly reduced for attachment to substrate also act as space fillers), reproduction (ovicells or gonozooid – specialized for brooding the eggs), cleaning (vibracula – flagellar operculum) of detritus building up on the colony and protection against fouling such as bacteria and diatoms (varicularia – well developed opercula, defend the colony) from the predators and grazers [137, 140]. The autozooids are functionally independent and they are composed of a cystid and a polypide.



The cystid is the outer casing that is attached to the body wall and the body cavity largely occupied by a spacious coelom. The polypide comprises of protrusible lophophore, U-shaped digestive tract and other internal organs such as nerve system. The lophophores or tentacles have a coelomic space that connects with other tentacles to form a coelomic ring, which is located at the base of tentacle crown. U-shaped digestive tract contains pharynx, a slender oesophagus, a stomach and a narrow intestine that passes to a short rectum that opens (mouth) and terminates (anus) near the ring of tentacles (lophophore). The nerve system, ganglion is located at the base of tentacles crown retractor muscles [136-138]. Bryozoans are suspension feeders and the autozooids collect food particles by using their ciliated tentacles to catch the prey, mainly diatoms and other phytoplankton from the surrounding seawater. Moreover, the bryozoan tentacles, or lophophores can be withdrawn inside of the body cavity for protection. Eversion of the withdrawn tentacles by retractor muscles is mainly controlled by the elevation of hydrostatic pressure of the body fluid. The nutrients are distributed to non-feeding zooids through mesothelial funiculus cords that are concentrated around the gut and extended to the communicating pore in the cystid body wall. Bryozoans are hermaphrodites with male and female zooids occurring in the same colony [142, 149, 150].



**Figure 11:** The schematic image of generalized bryozoan morphology is shown as a group of autozooids and a polymorphic zooid, ovicell. The separate image of autozooid can be seen above with labelled body parts. Lophophore (retracted and extended) and digestive tract are shown in orange. Skeleton and muscle are shown in black. The funicular bodies connect the zooid, can be seen in black dotted strands. Ovary (bottom) and Ovicell (top) are shown in yellow, in the left zooid. Testis (at the funicular bodies) can be seen in the left zooid.

**Reproduction:** The reproduction in bryozoans occurs, both sexually with dispersal of larvae and asexually by budding. The sexually mature zooids (gonozooids) produce eggs and spermatozoa. The embryos develop from fertilized eggs in the brooding chamber, and when mature, they are dispersed as free-feeding larvae ‘cyphonautes’ into the seawater. The non-feeding larvae typically settle on a suitable hard substrate, after they metamorphose into ‘ancestula’ larvae, which become an individual and functional zooid (autozooid) that begin a new colony. The colony continues to replicate genetically identical zooids by asexual budding to form a juvenile colony [138, 142].

### 1.6.2. Chemical defenses in marine bryozoans

The marine bryozoans are sessile and benthic marine invertebrate. In particular, cheilostome bryozoans have evolved to develop the skeletal structures at both zooidal and colonial levels and their polymorphic zooids such as avicularia or vibracula and varicularia are involved to defend against fouling organisms and infection by pathogenic microorganisms. Moreover, some marine bryozoan colonies have fragile forms including fenestrate, foliaceous and delicate branched and are more vulnerable to predation than encrusting species. Therefore, they are more prone to release active chemical compounds or secondary metabolites to defend against potential predators including amphipods and fishes [151-154].

The marine bryozoan secondary metabolites, bryostatins have significant ecological roles to the *Bugula neritina* larvae, which are free-swimming, soft-bodied and vulnerable to predators. A study demonstrated that the crude extracts of *B. neritina* larvae were unpalatable to fish. Moreover, it was shown that when the larvae of *B. neritina* was consumed by predators and the larvae were regurgitated, the metamorphosis of the bryozoan larvae were not hindered [155, 156]. Another group of marine bryozoan metabolites, the tamjamines, is a group of alkaloids, isolated from a variety of marine invertebrates including the marine bryozoan *Sessibugula translucens*, ascidians and nudibranchs [157, 158]. These secondary metabolites serve as an effective chemical defense against carnivorous fish. Bryozoan secondary metabolites can be transferred up through the food chain as bryozoans are a dietary source for the carnivorous nudibranch *Roboastra tigris*, *Tambja abdere* and *T. eliora* (dietary sources of *R. tigris*). These accumulated bryozoan secondary metabolites are further sequestered by nudibranchs and used as a chemical defense against their predator [153, 159]. A mixture of halogenated and non-halogenated tamjamines have been isolated from the nembrothid nudibranch and its dietary source, the bryozoan *S. translucens* and a study showed that these compounds were deterring the California spotted kelpfish *Gibbonsia elegans* in a fish feeding-aquarium assay. It has been observed that, high amounts of tamjamines in the bryozoan *S. translucens* tend to repel nudibranch predators [160, 161].

### 1.6.3. Chemical diversity in marine bryozoans

Marine bryozoans are well-known sources of bioactive compounds. Structurally diverse secondary metabolites have been identified from marine bryozoans including alkaloids, macrocyclic lactones,

sterols, tetracyclic terpenoids and sphingolipids. Many of these compounds exhibit antimicrobial, anticancer and antifouling activities [162]. Evidences suggested that, associated bacteria are the true producers of many of the secondary metabolites isolated from marine bryozoans [54, 163].

### ***Bacterial symbionts in marine bryozoans***

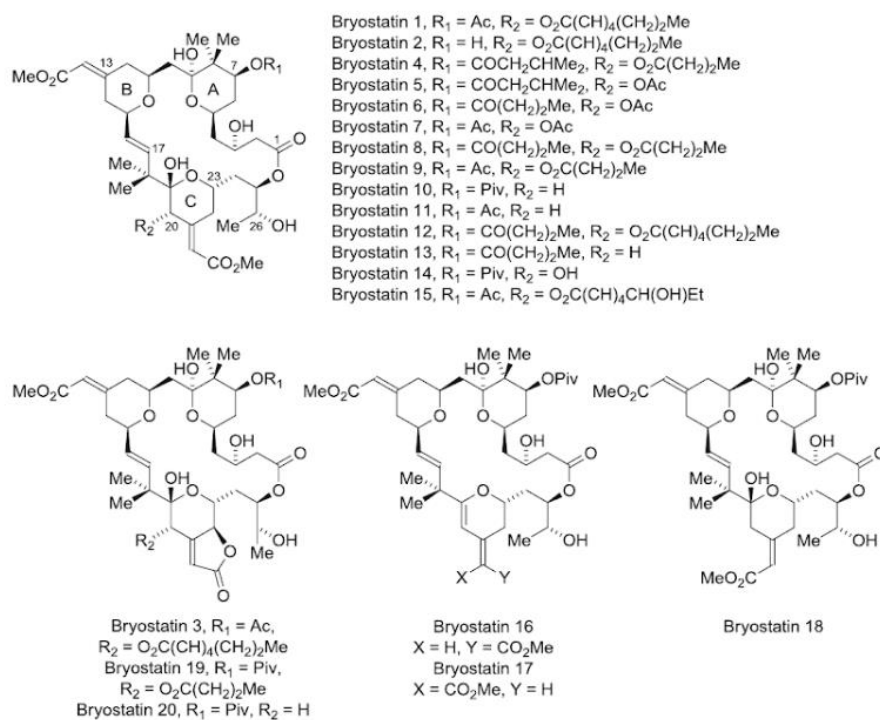
The marine bryozoans are colonized by either pathogenic or beneficial symbionts, and they can be found on the surface as biofilm or with in the bryozoan colonies, since bryozoans are filter feeders and are predominantly consuming unicellular algae [164-166]. The symbionts live in the funicular cords (connective tissues), avicularia (defense) and ovicells (brooding chambers), which are polymorphic zooids in bryozoan colonies [167-171]. In some cases, rod and irregular shaped bacteria were observed in the particular body part, 'pallial sinus' of the bryozoan larvae, *Bugula* sp. by transmission electron microscopy (TEM). This suggests that a vertical transmission of the bacterial symbionts in bryozoans are common [167, 172, 173]. For example, the uncultured endo-bacterial symbiont, *Candidatus* Endobugula sertula (*E. sertula*) are found in the larvae of marine bryozoan *B. nertina*. The adaptations of symbionts on bryozoans ensure lateral/vertical transmission and could possibly be advantageous to the bryozoan colonies [174, 175]. The surface associated bacteria on benthic invertebrate bryozoans are chemically mediated themselves or within the bryozoan colonies for nutritional exchanging, quorum sensing or deterring pathogens [96, 176]. Epibionts are able to colonize and establish biofilm on benthic marine bryozoans. An investigation of bacterial diversity in the North Sea bryozoan species *Flustra foliacea* revealed that alpha and gamma Proteobacteria including *Pseudoalteromonas*, *Shewanella*, *Bacillus* species, are found on the different body parts (distal, proximal and basal parts) of bryozoan colonies. The influence of bacterial colonies might be the production of secondary metabolites in *F. foliacea*. The nutritional relationship between the marine bryozoan, *Aquiloniella scabra* and their symbiotic bacteria has also been studied and suggested that the bacteria in the funicular bodies exchange the nutrients. In the sense that the small bristles like internal organs in *A. scabra* absorb the substances that are produced by bacteria. In return, the symbionts consume the mucus produced by a vestibular organ in bryozoans [164, 172]. Furthermore, the complex structure and function of the funicular bodies in marine bryozoans indicate that, the symbionts actively sway within the tissues of bryozoans and use them as an incubator for their growth and multiplications [164].

### ***Macrocyclic lactones - bryostatins***

Many natural products isolated from marine bryozoans have been suggested to originate from bacterial symbionts or derived from the diet. The bryostatins are well-known cytotoxic compounds isolated from the marine bryozoan *B. nertina*, which are collected from different geographical locations including the bay of Florida and China Sea waters [177, 178]. The bryostatins 1-20 share a common twenty-membered macro lactone ring with three functionalized tetrahydropyran rings and they differ predominantly in their substituents at the C-7 and C-20 positions, and whether a  $\gamma$  lactone ring is fused to the C-19 to C-23

tetrahydropyran ring. The bryostatins can also be categorized by the presence or absence of a 2,4-octadienoate moiety at their C-20 positions [177]. Recently, a new macrocyclic lactone, bryostatin 21 was identified and the novelty of bryostatin 21 is the presence of a single methyl group at C-18 compared with other previously isolated bryostatins [178].

Bryostatin 1 is produced by a species-specific endosymbiont, *Candidatus Endobugula sertula* (*E.sertula*). It is Gram-negative  $\gamma$ -proteobacteria, associated with the marine bryozoan *B. neitina*. [175] The biosynthetic gene cluster *bryA* has recently been found in *E. sertula* and it is responsible for the production bryostatin 1 [54, 71].



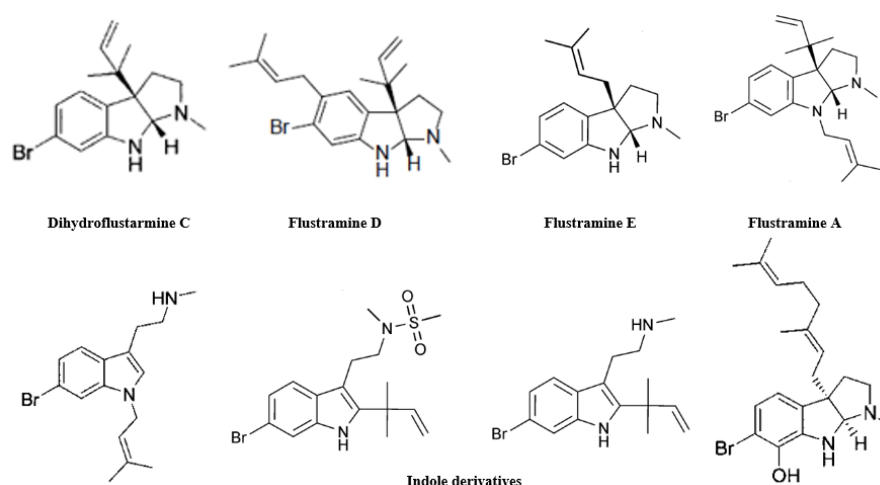
**Figure 12:** The chemical structure of bryostatin 1-20 isolated from marine bryozoan, *B. neitina*.

Bryostatins 1-21 exhibit a remarkable range of biological activities, including cognition and memory enhancement, cytotoxic, and synergistic chemo-therapeutic activities [178]. Among the 21 known macrolides, bryostatin 1 is unique as a protein kinase C (PKC) modulator. Bryostatin 1 modulates protein kinase C (PKC) activity with stimulating effects on haematopoietic progenitor cell growth and various leukocyte activities. However, due to its toxicity and side effects, bryostatin 1 was discontinued as an anticancer agent [54]. Nevertheless, clinical trials (phase I/II) with bryostatin 1 are still ongoing and bryostatin 1 has shown significant activity in cognition and memory enhancement and can possibly be used as a novel drug for Alzheimer's disease [179].

### Alkaloids

The group alkaloids is one the major secondary metabolites that has been frequently isolated from marine bryozoans. The flustramines and tamjamines could be related to bacterial or diet source.

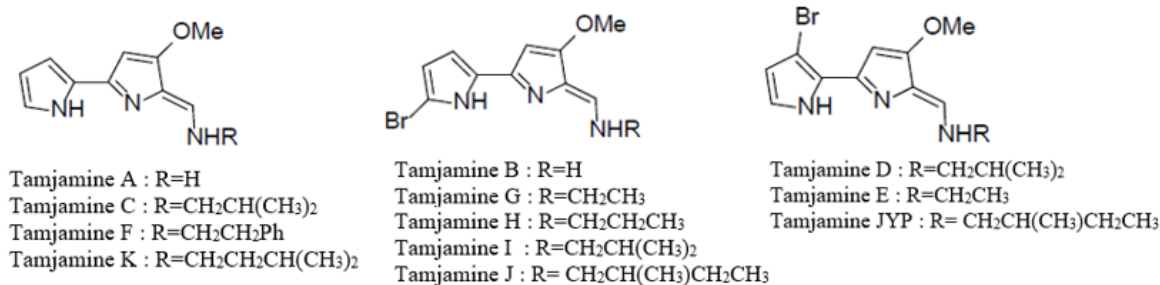
**Flustramines:** Flustramines are a group of structurally diverse brominated alkaloids and consist of pyrroloindoline and indole derivatives. To date, nearly 40 indole and indoline containing secondary metabolites have been reported from the North Sea bryozoan *Flustra foliacea* collected from different geographical locations including Scandinavian and Canadian waters. The flustramines exhibit a broad range of biological activities, and they have been reported that as being antibacterial, antifungal, muscle relaxing, inhibiting non-specific voltage sensitive potassium (K<sup>+</sup> ion) channels and acetylcholine inhibitory activities [162, 180-189]. The production of secondary metabolites in the North Sea bryozoan *F. foliacea* has been related to their associated bacteria. As described above in the section 5.7.1, the bacterial colonies were found in the different body parts of *F. foliacea*, however, the number of bacterial cells was significantly reduced in the growing body parts. This inhibition pattern indicated that the secondary metabolites from marine bryozoans could possibly be preventing the biofilm [172]. The isolated compounds from the North Sea marine bryozoan *F. foliacea*, dihydroflustramine C and flustramine D, exhibit antibacterial activity against Gram-positive bacteria such as *Staphylococcus aureus*, *Streptococcus epidermidis* and Gram-negative bacteria, *Escherichia coli* and *Pseudomonas aeruginosa*. In addition to that, flustramine E had antifungal activity. A significant antagonistic effect against biofilm was observed on some other indole derivatives and flustramine A [190].



**Figure 13:** Chemical structure of brominated secondary metabolites from marine bryozoans *F. foliacea*. (Flustramine A, D, dihydroflustramine C and flustramine E and indole derivatives)

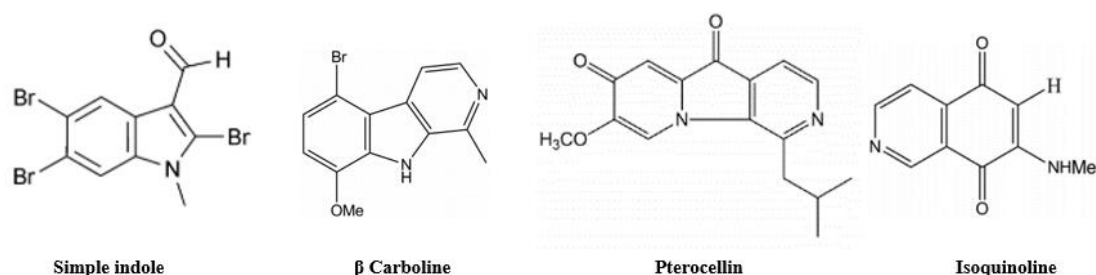
**Tamjamines:** Tamjamines are bi-pyrrole alkaloids that have been isolated from the marine bryozoans, *Bugula dentata* and *Sessibugula translucens*. These compounds have also been reported from the ascidian, *Atopozoa* sp. and their predator nudibranchs [83, 191]. Tamjamines are characterized by two pyrrole rings with an enamine moiety at C-5, and a methoxy group at C-4 in many of these compounds, the enamine nitrogen is substituted with a saturated short alkyl chain [192]. Besides their ecological role, tamjamines alkaloids possess a wide range of biological activities including antitumor, antimicrobial and immunosuppressive activities [192, 193].

The tamjamins are structurally similar to another compound, tamjamine YP1 (substituted with an unsaturated alkyl chain), which was isolated from the marine bacterium, *Pseudoalteromonas tunicate*. The biosynthetic gene cluster *Tam* for the production of tamjamins has been found in *P. tunicate*. This suggested that the marine bacterium, *P. tunicate* may be present in the tissues or surface of the marine bryozoan *B. dentana* and *S. translucens* [194, 195].



**Figure 14:** Chemical structure of tamjamins A-K from marine bryozoans and a secondary metabolite of bacterial symbiont, tamjamine JYP.

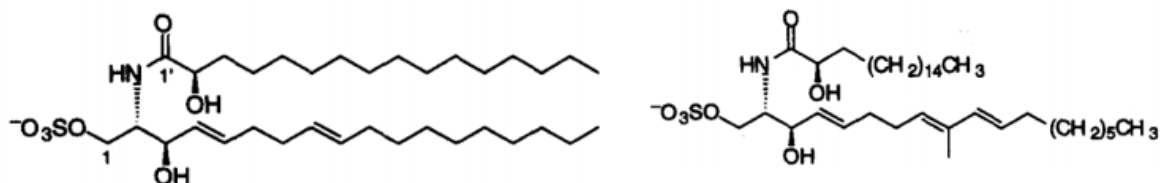
Apart from flustramines and tamjamins, several alkaloids have been isolated from marine bryozoans. The brominated indole–imidazole alkaloids, securamines A-I have been isolated from the North Sea bryozoan, *Securiflustra securifrons*. In addition, securines A and B were obtained by dissolving securamines A and B in DMSO-d<sub>6</sub> [196-198]. The simple indole, 2,5,6-tribromo-N-methylindole-3-carbaldehyde was isolated from the marine bryozoan, *Zoobotryon verticillatum* and showed antifouling activity against sea urchins embryos. The brominated tryptophan derivative, beta carboline (5-bromo-8-methoxy-1-methyl-beta-carboline), isolated from the marine bryozoan, *Cribricellina cribraria*, exhibited significant cytotoxicity against murine leukemia cell line P-388 and antimicrobial activity against *Candida albicans* and *Bacillus subtilis* [129]. Pterocellin is a true alkaloid, which contain nitrogen in the heterocycle ring and is an amino acid derivative. Pterocellins were isolated from the marine bryozoan, *Pterocella vesiculosa*, collected around the Chicken Island, North of New Zealand. Pterocellins possess an unique heterocyclic skeleton (a tricyclic pyrido [4,3-b] indolizine ring system, which exhibited cytotoxic activity against murine leukemia cell line P-388 and antimicrobial activity against *E. coli* and *C. albicans* [199, 200]. Calibugulones are an isoquinoline alkaloid type, identified from the marine bryozoan, *Calibugula intermis* collected from the South Pacific off Palau, and displayed significant cytotoxicity against the IC-2WT murine tumor cells [201].



**Figure 15:** Chemical structures of bryozoan's alkaloids

## Sphingolipids

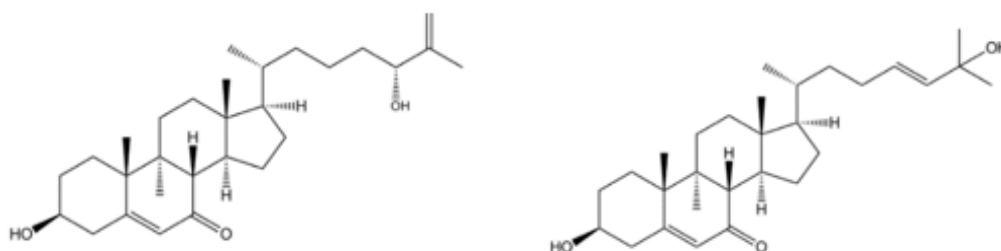
Sphingolipids are characterized by a sphingoid base with a long chain fatty acid. They consist of two groups such as ceramides and cerebroside. Two novel sulfate of ceramides (**Fig 16**) were identified from the Japanese marine bryozoan, *Watersipora cucullata*. Sulfates of ceramide showed a significant inhibition against human topoisomerase 1 by inhibiting its DNA binding activity and could be developed as inhibitors for topoisomerase 1 for treating cancer [202, 203]. Furthermore, six ceramides were reported from the marine bryozoan *B. neritina*, collected from the South China [204].



**Figure 16:** Chemical structures of ceramides A and B

## Terpenoids and sterols

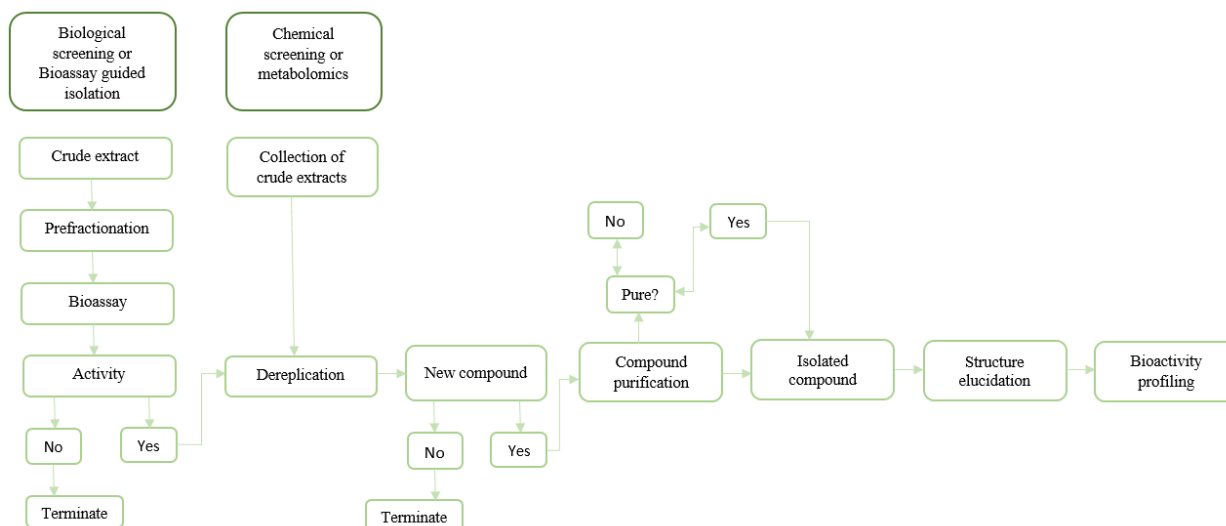
A novel tetracyclic terpenoid lactone, murrayanolide was identified from bryozoan, *Dendrobeatia murrayana*, collected from Canadian waters. Murrayanolide possesses an unusual C<sub>21</sub> skeleton and it exhibited significant inhibition against metalloprotease collagenase IV [205]. Sterol is one of the most important chemical classes isolated from marine bryozoans. Approximately 20 sterols have been isolated from the *Bugula neritina* species alone [203, 206, 207]. For example, two new oxygenated sterols,  $3\beta,24(S)$ -dihydroxycholesta-5,25-dien-7-one and  $3\beta,25$ -dihydroxycholesta-5,23-dien-7-one (**Fig 17**) were isolated from the marine bryozoan *B. neritina* which was collected in Daya Bay, Guangdong Province, China [130]. It has been suggested that, the potential sources of sterols in *B. neritina* are more likely derived from the dietary origin [208].



**Figure 17:** Chemical structure of sterols isolated from the marine bryozoan, *B. neritina*.

## 1.7. Methodology

The standard workflow from crude extract to pure compound performed in Marbio has been modified based on this thesis requirement (**Fig 18**). The workflow is initiated with crude extract and prefractionations to bioactivity profiling of isolated compounds. The methods are briefly described below.



**Figure 18:** Schematic workflow of biological and chemical screening.

The collected bryozoan samples were lyophilized and extracted, fractionated and bioassayed. The crude extracts were selected from the preliminary biological and chemical screening. The target compounds were isolated, and their structures were elucidated using various spectroscopic techniques (HR-MS and 1D and 2D NMR).

### 1.7.1. Extraction and sample preparation

The lyophilized marine invertebrates were ground into fine particles to improve the kinetics of extraction by increasing the contact surface of the sample with the organic solvent [209]. The powdered samples were extracted into aqueous and organic (Dichloromethane and methanol) extracts. The crude extracts from marine invertebrates are usually complex mixtures and contain large amounts of inorganic salts and non-polar compounds along with bioactive components. In order to remove such impurities, the crude extracts were fractionated using several techniques including liquid-liquid separation and chromatographic techniques. In liquid-liquid partition, two immiscible liquids (polar and non-polar solvents) are used to remove certain compounds from the crude extract [210]. The sample was dissolved in hexane and methanol and partitioned against water. The hexane and water were used to separate lipophilic and hydrophilic compounds [211]. Flash chromatography is another option for the separation of crude extracts into fractions. In flash chromatography, the mobile phase is pumped through the



stationary phase in a prepacked column, which is packed with adsorptive macroporous resins (*e.g.*: HP20SS). In this thesis, the crude extracts were pre-purified by liquid-liquid partitions prior to flash fractionations or HPLC-HRMS in order to identify and purify the target compounds (described in paper 1 and 2). The obtained flash fractions were tested for bioactivity [63]. The semi-purified or active fractions are subjected to dereplication process as described in section 1.3.

### **1.7.2. Isolation by using preparative high-performance liquid chromatography (HPLC)**

The main aim of natural product purification is the isolation of target compounds. Isolation is a process, which separates a compound or more compounds from each other in a crude extract or fractions. The repeated steps of separations provide sufficient amounts of purified compounds that will allow for chemical characterization and bioactivity testing. The nomination of target (dereplicated) compounds are not only based on the preliminary bioactivity results (*e.g.*: bioassay-guided isolation), but also based on potential chemical novelty and abundancy in the crude extracts [64]. The isolation and purification of target compounds can be carried out by various chromatographic techniques. In chromatographic techniques, the molecules in crude mixture are distributed between two phases, a mobile phase carries the extract through a stationary phase. HPLC is one of the most versatile techniques for the efficient separation of natural products and it provides high-resolution power that improves sensitivity and facilitates the detection the minor components present in the complex crude mixtures. In HPLC, the molecules in crude mixture or fractions are forced by liquid mobile phase at high pressure and the separation is mainly based on compounds' distribution between a solid stationary phase and the mobile phase. Prep HPLC is commonly used to separate the components of a mixture repeatedly for purification purpose [8]. Reverse phase columns are the most common approach for the isolation of MNPs in prep HPLC. In the RP HPLC, the mobile phase is significantly more polar than the stationary phase in the sense that hydrophobic molecules in the mobile phase tend to adsorb to the relatively hydrophobic stationary phase and hydrophilic molecules in the mobile phase tend to elute first [210]. The column in RP prep HPLC is mainly packed with C18 (octadecyl) coupled to the silica particle substrate. The surface modification of packing material in the column determines the interactions between the target compound(s) and the stationary phase. Other types of RP columns can also be used such as phenyl-hexyl and fluorophenyl. The separation of compounds in RP prep-HPLC with a C18 are generally performed by using two solvents usually water and an organic solvent such as acetonitrile or methanol. The solvent system is usually supplemented with acid, in order to improve separation efficiency [66]. Prep HPLC combined with mass spectrometry assists the isolation of target compounds. The fraction collector of the prep HPLC collects the target compounds through mass triggering. When the eluting compound reaches its threshold intensity of a target mass, the fraction collector is triggered by MS data. To achieve

this, the flow of separated compounds from the column splits about 1% to the MS and UV detector and remaining 99% proceeds to the fractions collector [66].

### **1.7.3. Structure elucidation**

Various analytical spectroscopic techniques such as UV–visible spectroscopy, infrared absorption spectroscopy and NMR are often used for determining the chemical structure of secondary metabolites. A combination of these techniques provides structural information of the unknown metabolites.

#### ***High Resolution – Mass Spectrometry (HR-MS) analysis***

Mass spectrometry is an analytical technique that aims to determine a molecular mass of a compound. A mass spectrometer consists of three components; an ion source, a mass analyzer and a detector. The sample is introduced into an ionization source, where the sample molecules are vaporized and ionized. These charged ions are transported to the mass analyzer, where they are separated based upon their mass-to-charge ratio ( $m/z$ ). Finally, the sorted ions pass to a detector that converts the ion energy into electrical signals. A data system collects and processes data from the detector. The MS data provides the information about molecular masses, relative abundance and isotopic patterns, which can be used to calculate elemental composition of the compounds [212]. In this thesis, UPLC-HR-MS with electrospray ionization was used. UPLC allows for rapid and efficient separation of complex crude extracts, since it operates at high pressures (up to 1200 bar) with small particle size (2  $\mu\text{m}$ ) of packing material in the column. UPLC provides short analysis times as well as high peak capacity, sensitivity and reproducibility [213, 214]. Electrospray ionization (ESI) is the common ionization technique for polar compounds. In ESI, the solvent molecules are sprayed into fine droplets (aerosol) and the electrically charged particles transfer into gaseous phase ions before they enter to mass analyzer [212]. ESI is a soft ionization technique that can be operated both positive and negative mode and it produces little fragmentation. HR mass analyzers allows separating ions with similar masses and are used to determine molecular mass with high accuracy (*e.g.*:  $m/z$  357.0926) [8]. The detected ions by HRMS are plotted as  $m/z$  verses relative abundance in percentage (%).

#### ***Nuclear magnetic resonance (NMR)***

Nuclear magnetic resonance is a spectroscopic technique, which is based on the absorption of electromagnetic radiation in the radio frequency by nuclei of the atoms. In the presence of a strong magnetic field, nuclei such as  $^1\text{H}$  and  $^{13}\text{C}$  are able to absorb the radio frequency energy and they begin to resonate at different frequencies. This resonance is used to study the structural information of the molecules including the number of carbon and proton atoms and their connectivity. The NMR is dependent upon the atomic nuclei having magnetic properties.  $^1\text{H}$ ,  $^{13}\text{C}$  are the most commonly studied nuclei and have nuclear spins ( $1/2$ ). In the absence of an external magnetic field, each nuclei is randomly oriented. When the sample of the nuclei is placed in an external magnetic field, the nuclear spin has two

possible orientations, either align themselves (+1/2) or against (-1/2) to the field of the external magnet. The electromagnetic radiation of the frequency causes the nuclei to flip from aligning (absorption of lower energy) to aligning against (absorption of higher energy) to the magnetic field. The applied energy transfer is possible between ground states to excited state. When the spin returns to its ground state level, the absorbed radio frequency energy is emitted at the same frequency level can be measured. The emitted radiofrequency signal provides the NMR spectrum of the concerned nucleus. The NMR spectrum is plotted by applied radio frequency versus intensity of NMR signal in reference to tetramethylsilane (TMS). The proton and carbon spectra provide information about chemical shift, spin-spin coupling constant, relaxation time and signal intensity. Chemical shift provides information about the composition of atomic group within a molecule (*e.g.*: what type of nuclei whether proton or carbon and how many in numbers). Coupling constants provide an information on adjacent atoms in the sense that which nuclei are connected to each other and signal intensity provides a quantitative information such as atomic ratios within a molecule [8, 214, 215]. In this thesis, the one dimensional and two-dimensional NMR experiments were used for the structure elucidation of the bryozoan secondary metabolites presented in papers 1 and 2. The 2D NMR experiments were correlation spectroscopy (COSY), total correlation spectroscopy (TOCSY), heteronuclear multiple bond correlation (HMBC), heteronuclear 2-bond correlation (<sup>2</sup>HBC) heteronuclear single quantum correlation (HSQC). Overhauser effect spectroscopy (NOSEY) and rotating frame nuclear overhauser effect spectroscopy (ROSEY). <sup>15</sup>N heteronuclear correlation (HMBC and HSQC). The information from each different NMR experiment, used in structure elucidation of isolated compounds, is summarized in a Table, which can be seen below.

NMR experiment	Information
<sup>1</sup> H	Identification and number of protons
COSY	Identification of protons that are coupled to each other or neighboring protons
TOCSY	Identification of coupled proton and identification of spin system
HSQC	Identification of connected proton-carbon
HMBC	Identification of connected proton-carbon by 2 or 3 bonds
<sup>2</sup> HBC	Identification of protons and proton-bearing carbon spins by two bonds correlations
NOSEY and ROSEY	Information about special relationship between protons

#### 1.7.4. Bioactivity profiling of isolated compounds

After isolation, the bioactivity profile of the pure compounds is determined using different bioassays. The bioassays can be biochemical or cell-based assays. Cell-based assay measures the ability of a compound to cross the cell membrane and reduced the intracellular metabolic activity within the cells or disruption of the cell membrane on cells (*e.g.*: disruption of cell membrane leads to cell death or growth inhibition by reducing metabolic process - bacteriostatic). Alternatively, biochemical assays are able to detect and quantify effects on a specific cellular process or metabolic reactions [39, 66]. The

disadvantage of biochemical bioassay does not determine compounds' properties such as membrane permeability, cytotoxicity and off targets effects. However, biochemical assays are simple, more consistency and direct measurement of defined targets such as enzymes, receptors and cellular proteins. The combination of both types of bioassays are useful for bioactivity profiling of isolated compounds [66]. In this thesis, the pure compounds were tested with a panel of available bioassays such as anticancer and antimicrobial, immune modulatory (anti-inflammatory TNF- $\alpha$ ) cell-based assays and, diabetes (PTP1-B) and antioxidant (ORAC) biochemical based assays.

## 2. Aim of the thesis

Marine bryozoan is a prolific source of structurally diverse bioactive secondary metabolites. However, the total number of natural products isolated from marine bryozoans is limited, and only 78 new secondary metabolites from this group have been reported since 2008. The phylum Bryozoa is one of the major groups of diverse benthic invertebrates in the high polar-regions. The diversity of Arctic marine bryozoans is estimated to be about more than three hundred species, but the number of new secondary metabolites isolated from cold-water marine bryozoans is low. Thus, the aim of the present study was to find new natural products with novel structures from Arctic marine bryozoans. The discovery of new marine natural products can potentially provide new and improved therapeutics for human illnesses, along with other innovative products for other industrial activities such as nutraceuticals and biotechnology applications. The goal of this thesis was to isolate and to elucidate the structures of new secondary metabolites from Arctic marine bryozoans, and to test the isolated compounds for potential bioactivities using available bioassays. To achieve this goal, two Arctic marine bryozoans, *Securiflustra securifurans* and *Dendrobeatia murrayana*, were collected from the Norwegian coast and investigated using the Marbio marine bioprospecting pipeline.

The main objectives of this study were,

Identification of compounds in crude extracts based on either bioactivity or structural features.

- 1) Identify new compounds in fractions/crude extract based on either primary screening of bioactivity or difference between in other chemical compounds present in various Arctic marine bryozoans
- 2) Dereplication of the bioactive fractions/crude extract to identify target compounds
- 3) Isolate the target compounds
- 4) Structure determination of the target compounds

Test potential bioactivity of compounds isolated from the bryozoans

### 3. Summary of papers

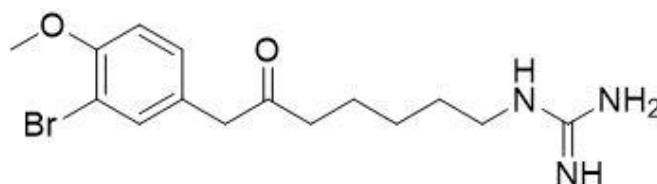
#### Paper I

Priyanka Michael, Kine Ø. Hansen, Johan Isaksson, Jeanette H. Andersen, Espen Hansen.

#### **A Novel Brominated Alkaloid Securidine A, Isolated from the Marine Bryozoan *Securiflustra securifrons***

*Molecules*, 2017, 22, 1-11.

A novel mono brominated tyrosine derivative, securidine A (**Fig 19**) was isolated from the Arctic marine bryozoan, *Securiflustra securifrons*. Flash fractions from an aqueous extract of *S. securifrons* showed cytotoxicity against the A2058 human melanoma and HT29 colon adenocarcinoma cell lines. Chemical investigation of the bioactive flash fractions using UPLC-HRMS revealed the presence of a mono brominated compound. The compound had an elemental composition that did not match any known marine natural products, so it was isolated through mass guided fractionation on semi-preparative HPLC. The chemical structure of the compound was elucidated by spectroscopic (1D and 2D NMR) techniques. The alkaloid compound, named securidine A, had a novel structure consisting of a brominated tyrosine, and it was not structurally related to any previously described compounds from *S. securifrons*. To test potential bioactivities of the pure compound, securidine A was tested against cancer cell lines using an MTS based anticancer assay. Securidine A did not show any significant cytotoxicity against the human melanoma or colon adenocarcinoma cell lines at 100  $\mu$ M. Securidine A was further evaluated with various bioassays including antibacterial activity against *Staphylococcus aureus*, *Escherichia coli*, *Pseudomonas aeruginosa*, *Enterococcus faecalis* or *Streptococcus agalactiae* (gr.B), inhibition of protein tyrosine phosphatase B (PTP-1B) for antidiabetic activity as well as biofilm inhibition against *S. epidermidis* (all assays tested up to 100  $\mu$ M). The compound did not show any significant bioactivity from the panel of selected bioassays.



**Figure 19:** The molecular structure of securidine A.

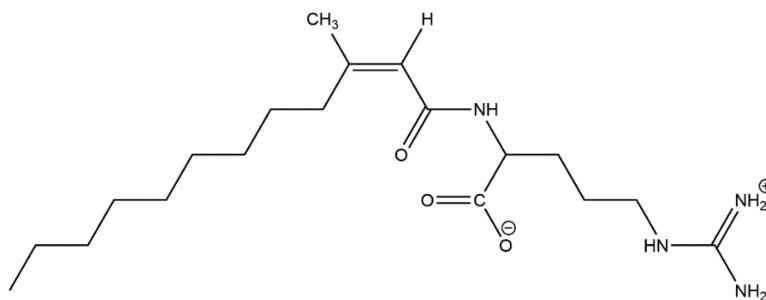
## Paper II

Priyanka Michael, Espen Hansen, Johan Isaksson, Jeanette H. Andersen, Kine Ø. Hansen.

### **Dendrobeaniamine A, A New Alkaloid from the Arctic Marine Bryozoan, *Dendrobeatia murrayana*.**

*Natural Product Research*, 2019, 1-6.

A chemical investigation of the crude organic extract of the Arctic marine bryozoan *Dendrobeatia murrayana*, collected off the Norwegian coast, led to the isolation of a new secondary metabolite, dendrobeaniamine A (**Fig 20**). Dendrobeaniamine A is a lipo-amino acid, which consists of a C<sub>12</sub> linear fatty acid that is connected to a positively charged L-arginine amino acid. A detailed chemical analysis of the organic crude extract of *D. murrayana* using UPLC-HRMS revealed the presence of a prominent peak at R<sub>t</sub> 5.7 min with a *m/z* 369.2861. The calculated elemental composition was C<sub>19</sub>H<sub>36</sub>N<sub>4</sub>O<sub>3</sub> and it gave no hits when searched for in relevant databases (Dictionary of marine natural products and ChemSpider). The compound was isolated through mass guided fractionation using semi-preparative HPLC. The chemical structure of dendrobeaniamine A was determined by using spectroscopic methods (1D and 2D NMR). The amphipathic structure of dendrobeaniamine A was evaluated for bioactivity based on cellular and biochemical assays but the isolated compound did not show cytotoxic, anti-inflammatory, antimicrobial or antioxidant activities.



**Figure 20:** Chemical structure of dendrobeaniamine A

## Paper III

Kine Ø. Hansen, Ida Kristine Ø. Hansen, Celine S. Richard, Priyanka Michael, Marte Jenssen, Jeanette H. Andersen, and Espen Hansen

### Antimicrobial Activity of Securamines from the Bryozoan, *Securiflustra securifrons*

In revision, submitted to *Marine Drugs*.

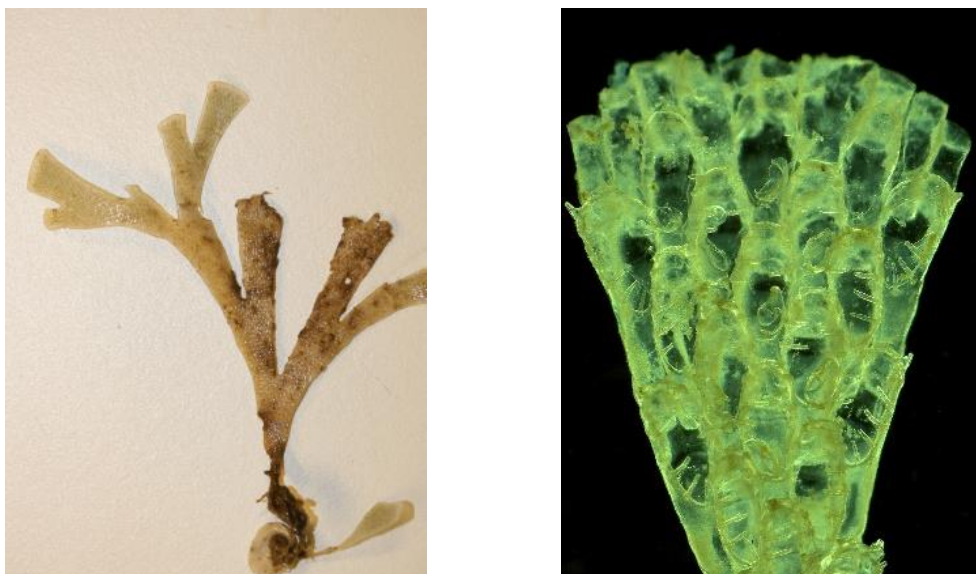
Marine bryozoans are sessile and benthic invertebrates. To prevent attacks from pathogenic bacteria, they are known to utilize chemical defense mechanisms. The present study investigated the antimicrobial activity of a series of previously isolated secondary metabolites, securamine C (**4**), E (**5**) and H – J (**1** - **3**), isolated from the Arctic marine bryozoan *Securiflustra securifrons* against pathogenic bacteria. In addition, securidine A (**6**) was tested for synergistic antibacterial effect in combination of securamine H (**1**) against five pathogenic bacterial strains. The flash fractions (one to eight) from the organic extract of *S. securifrons* were screened for antibacterial activity and fraction three was found to be active against the pathogenic bacterium, *Streptococcus agalactiae* (gr.B). Chemical investigation of this fraction using UPLC-HRMS revealed that it contained several variants of the securamines along with abundant amounts of brominated tyrosine derivative, securidine (**6**). Compound **6** was previously determined to be inactive against bacteria and biofilm formation at 100 µM. Compounds, H (**1**), I (**2**) and E (**5**) were found to be active against all test G+ strains. The most potent antibacterial activity was exhibited by compound **1** with the lowest MIC measured value of 3.13 µM. The mode of action of **1** was investigated by using modified variants of the G+ bacteria, *Bacillus subtilis* and the G- bacteria, *E. coli*. Compound **1** did not affect *B. subtilis* viability by bacterial membrane integrity disruption but it was found to be active against *B. subtilis* by interfering with their metabolic machinery. Therefore, Securamine H (**1**) was tested for its ability to inhibit several metabolic processes including DNA replication, transcription and folic acid synthesis. We were not able to identify the intracellular target of securamine H (**1**). Finally, securamine H (**1**) and securidine A (**6**) were tested for synergistic effects against G+ and G- pathogenic bacterial strains, since both compounds were largely present in the fraction three, a fraction displaying antibacterial activity. No such activity was found.



## 4. General discussion

The phylum Bryozoa is well-known to produce diverse marine natural products. Exploring untapped geographical sources, including cold waters bryozoans, offers new natural products with unusual chemical structures. Bryozoans are the most dominant benthic marine invertebrate in the Arctic Ocean. Marine bryozoans in Svalbard waters (between 50° to 70°N) are mainly represented by Arctic and boreal Arctic species [145]. Nevertheless, a high number in Arctic bryozoan species have received little attention with regard to studies of their natural products compared to tropical species [216, 217]. The evolution of chemical diversity in benthic marine invertebrates is not mainly driven by predator interaction, which is high in tropical waters, but there are number of interactions constantly involved in the complex marine ecosystem, which are accountable for the biosynthesis of natural products [71]. In particular, psychrophilic organisms in the Arctic regions possess diverse array of biochemical and physiological adaptations towards to various external parameters including low temperature, strong winds and high ultraviolet radiation. These adaptations are often accompanied by modifications to both gene regulation and metabolic pathways and increasing the possibility of finding new secondary metabolites with pharmaceutical interest [71, 218].

At the commencement of the present work, two boreal arctic bryozoan species collected from the Svalbard waters were extracted and investigated for new natural products (paper 1 and 2). The antibacterial activity of the isolated compounds from *S. securifrons* and their potential synergistic effects were also studied (Paper 3). The biological samples were provided by the Norwegian national marine biobank Marbank (Institute of Marine Research, Tromsø, Norway), and they were collected off the coast of West Spitzbergen and in Vesterålsfjorden by trawl and scuba diving at a depth range between approximately 30-70 meters. The marine organisms were immediately frozen at -23°C and lyophilized before extraction. The collected bryozoans had erected forms and were weakly calcified, belong to the class Gymnolaemata and order Cheilostomata [137]. The images of the bryozoans species *Securiflustra securifrons* (belongs to Flustridae family) and *Dendrobeania murrayana* (Bugulidae family) can be seen in **Fig 21**. These sample materials provided sufficient amount of biomass for isolating the target compounds in quantities, which allowed for characterizing their molecular structures as well as a limited number of bioactivity testing. A total amount of pure compound securidine A isolated from *S. securifrons* was 2.65 mg and dendrobeaniamine A isolated from *D. murrayana* was 2.5 mg. For the initial biological evaluation, the isolated compounds were tested with biochemical and cell-based assays, which are available in the Marbio laboratory. Any bioactivity of pure securidine A and dendrobeaniamine A have not been revealed yet.



**Figure 21:** An image of marine bryozoans *S. securifrons* (to the left) and *D. murrayana* (to the right)  
Photo: Robert Johansen, Marbank

#### 4.1. Supply issues

A sufficient supply of pure compounds is a major challenge in marine natural product drug discovery because the abundance of secondary metabolites in marine invertebrates is usually very low. For example, bryostatin 1 is a lead compound for the development of anticancer drug, and it was isolated from the marine bryozoan *Bugula neritina*. For structural elucidation, a total of 500 kg of marine bryozoans was harvested and the wild harvesting of *B. neritina* provided very low yield (unpublished) of pure bryostatin 1, but the yield of bryostatins 2 and 3 were 314 mg and 81.5 mg respectively [219]. For biological characterization by the National Cancer Institute, USA, about 14 tons of source organism were made by ‘hand collection’, which provided only 18 g of bryostatin 1 (0.00014% yield) [220]. To obtain large quantities of pure compound and constant supply for drug development, bryostatin 1 was originally produced through aquaculture and mariculture. Nevertheless, both methods produced approximately 100 g of bryostatin 1 per year, which was not economically feasible (\$ 30,000 per gram of bryostatin 1). Therefore, bryostatin 1 was totally synthesized in 1990. In addition, bryostatin 1 was simplified to a more potent analogue based on the specific interaction with the target protein [221]. Another example is the FDA approved drug Ecteinascidin 743, which was isolated from the colonial ascidian *Ecteinascidia turbinata* and reported for its antitumor activity in 1969. The yield of pure compound was 0.0001% [109]. In order to overcome the supply issue for drug development, the marine invertebrate was cultivated in Mediterranean aquafarms during 1998-2003 and produced a total of 100 metric tons of tunicate biomass [221]. For commercialization purpose, the complex compound, trabectedine was totally synthesized through 32 steps in 1996 for avoiding the dependency on one natural source. However, the total synthesis was not feasible for manufacturing ET-743 at an industrial

scale. Therefore, this compound was obtained by semi-synthesis through fermentation of the bacteria *Pseudomonas fluorescens* [114]. The isolated pure compounds securidine A and dendrobeaniamine A are new natural products, as they have not been reported earlier. To isolate more of the compounds for more extensive bioactivity studies, the bryozoan species can be recollected off the coast of northern Norway, since they are found in abundant amounts in the North Sea and the Barents Sea [137]. However, the content of secondary metabolites in marine organisms varies depending on seasonal changes, effects of predators and locations. Notably, dendrobeaniamine A was not present in *D. murrayana* specimens collected in off the Coast of Bear Island (data not shown). Securidine A and dendrobeaniamine A can also potentially be synthesized chemically to obtain larger amounts.

## 4.2. Preparation of crude extract into fractions and bioactivity screening

Briefly, the collected Arctic bryozoans *S. securifrons* and *D. murrayana* were extracted with aqueous and organic solvents. As referred in paper 1, the freeze-dried and pre-purified aqueous extract of *S. securifrons* were prefractionated into eight fractions by using column chromatography with a flash purification system. The extract was eluted with a gradient of water, methanol and acetone and the obtained fractions were screened for initial bioactivity using melanoma and colon carcinoma cell lines. The active fractions four and five were nominated for dereplication. In another approach, chemical screening was used to identify new natural products in the pre-purified organic extract of *D. murrayana* as described in paper 2. Both methods revealed the importance of dereplication in order to avoid reisolation and characterization of previously reported compounds. In the chemical screening, the isolated new natural product was not defined by its bioactivity in the initial examination. In contrast, bioassay guided isolation was defined by the bioactivity that was used in the bioassay when isolating the target compounds. Natural products are viewed as privileged structures selected by evolutionary pressures and able to interact with specific targets and the bioactivity of new isolated compounds can be discovered at a later stage. For example, the NFkB inhibitor hymenialdisine, isolated from the marine sponges *Acanthella* sp and *Axinella* sp. in 1982, did not exhibit any significant bioactivities in the initial examination. In 2000, it was shown to be an ATP competitive inhibitor of multiple kinases [222, 223]. Nevertheless, both methods are efficient for identifying new natural products with interesting chemical structures.

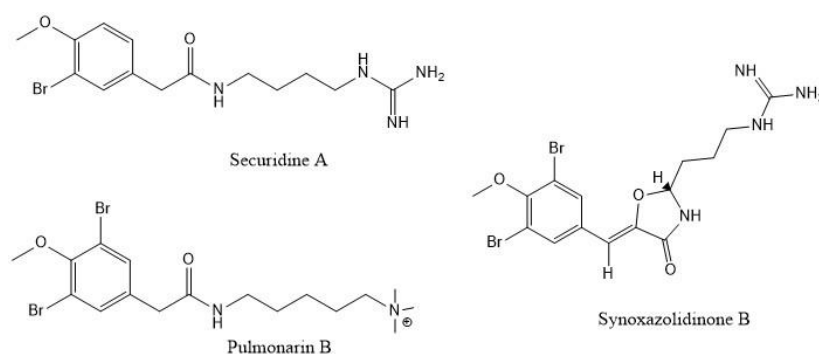
## 4.3. Dereplication of crude extracts of *S. securifrons*

The fractions four and five of the extract of *S. securifrons* displayed cytotoxic activity (Paper 1). The chemical analysis of flash fractions using UHPLC-HR-MS revealed that a compound contained a single bromine. The mono brominated compound was named securidine A and the mass of the protonated molecule was  $m/z$  357.0858 ( $[M+H]^+$ ). The calculated protonated elemental composition of securidine A was  $C_{14}H_{21}BrN_4O_2$ . A database search indicated that the isolated compound was novel. The

dereplicated compound securidine A was isolated through prep-HPLC in order to obtain adequate amount for chemical and biological characterization. For this purpose, the aqueous crude extract of *S. securifrons* was pre-purified by liquid-liquid partition and the methanol phase, which contained the target compound securidine A, was collected and reduced to dryness and resuspended into 80% methanol. Securidine A was isolated through mass-guided fractionation, and the mass of protonated securidine A (357 Da) was used as a collection trigger. Initial purification of securidine A was achieved by a RP C18 HPLC column with a 10 minutes gradient of acetonitrile from 10% to 40%. For a second purification step, the collected fraction was dried and redissolved in 80% methanol and injected onto a phenyl-hexyl column. Securidine A was eluted with a 10 min gradient of acetonitrile from 10 to 34%. The molecular structure of securidine A was solved based on a number of 1D and 2D NMR experiments as described in paper 1.

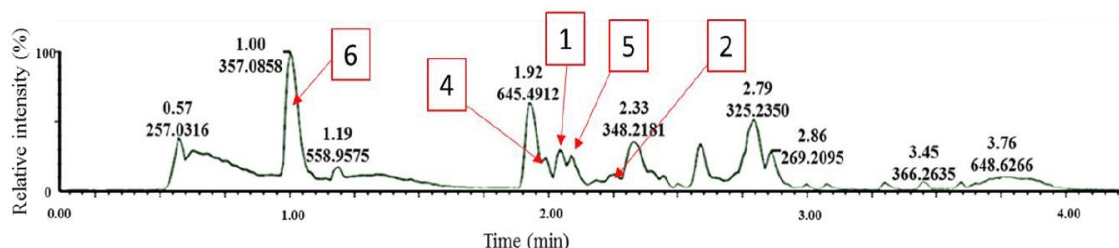
#### 4.4. Bioactivity profiling of securidine A

Securidine A is a brominated tyrosine derivative. Securidine A is not structurally similar to the other halogenated indole imidazole alkaloids (securamines A-J) which were isolated from *S. securifrons* collected in the North Sea (see paper 1 and see reference in [198]). Many marine organisms including ascidians and sponges are well-known to produce brominated tyrosine derivatives, which have been found to have antibacterial (*e.g.*: synoxazolidinone) and acetylcholinesterase (*e.g.*: pulmonarin B) and antifouling (*e.g.*: baretin) properties (**Fig 22**). These compounds have different substitutions but are structurally related. The  $\beta$ -phenylethylamine compounds, amathamides have been reported from the marine bryozoan *Amathia* sp. This type of alkaloids is presumably derived from amino acid and biosynthesized through biochemical reactions such as specific incorporation of halogens and methylation [224, 225]. The structures of these secondary metabolites share a common molecular skeleton. The  $\beta$ -phenylethylamine compounds isolated from bryozoans are known for their bioactivities such as antitrypanosomal, anthelmintic and cytotoxic activities [176, 224]. However, no bioactivity of securidine A was found against melanoma, adenocarcinoma and breast cancer cell lines nor G<sup>+</sup> and G<sup>-</sup> pathogenic bacteria. It also showed no inhibition of protein tyrosine phosphatase 1B (PTPT-1B) for antidiabetic activity.



**Figure 22:** Securidine A and its structurally related brominated compounds

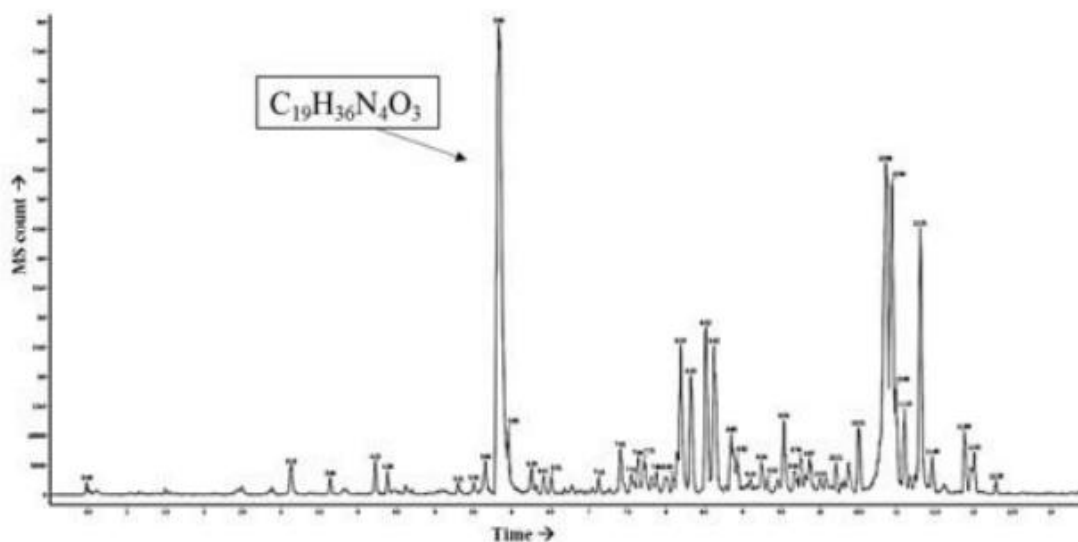
On the other hand, the flash fractions of the organic crude extract of *S. securifrons* were screened for antibacterial activity against *Staphylococcus aureus*, *Enterococcus faecalis*, *Escherichia coli*, *Pseudomonas aeruginosa* and *Streptococcus agalactiae* (gr.B) at 250 µg/ml. Fraction three was found to be active against G + bacteria *S. agalactiae*. The chemical analysis of the flash fraction using UHPLC-HR-MS showed that the fraction contained a various group of compounds (securamines C, E and H-J – reported earlier, see reference in [198] along with securidine A. The series of securamines was present in low amounts, while securidine A was found to be abundant (**Fig 23**). In many cases, the presence of major compounds might mask the bioactivity of minor compounds [53] or synergistic interaction between multiple components might potentiate the bioactivity each other or loss of the bioactivity also known as antagonistic effect [226]. To address this, securamine C, E, H, I and J and securidine A were tested for antibacterial activity. Securidine A was found to be inactive against G + and G- bacteria. The pure compounds securamines 1-5 were tested against G + and G - pathogenic bacteria and yeast strains as well as the ability to inhibit biofilm formation in *Streptococcus epidermidis* was also studied at the highest concentration 50 µM (paper 3). The securamines H, I and E displayed antibacterial activity against G+ positive bacteria. Among these, securamine H was the most active against *B. subtilis*, *S. aureus*, *E. faecalis*, *S. agalactiae* and the MIC value was ranging from 6.25 µM to 3.13 µM. Therefore, securamine H was chosen for mode of action studies with modified variants of G + bacteria *B. subtilis* and G- bacteria *E. coli*. These studies revealed that the cell viability of *B. subtilis* was not affected by securamine H through membrane integrity disruption at the highest concentration. Nevertheless, securamine H reduced the metabolic activity of this G+ bacteria. Furthermore, securamine H was investigated for its interference with bacterial intracellular metabolic process and no activity was observed. To address any synergistic interactions, the minor compound securamine H and the major compound securidine A were assayed using a checkerboard titration method against pathogenic strains mentioned above. Synergistic combination of two or more natural products might significantly enhances the overall effect. However, no synergistic effect was not observed between securamine H and securidine A against *S. aureus*, *E. faecalis* and *S. agalactiae*.



**Figure 23:** The base peak intensity chromatogram of flash fraction three of the organic extract of *S. securifrons* showed the presence of several securamines, including securamine H, I, C and E (**1, 2, 4 and 5**) and securidine A (**6**).

#### 4.5. Dereplication and bioactivity profiling of dendrobeaniamine A

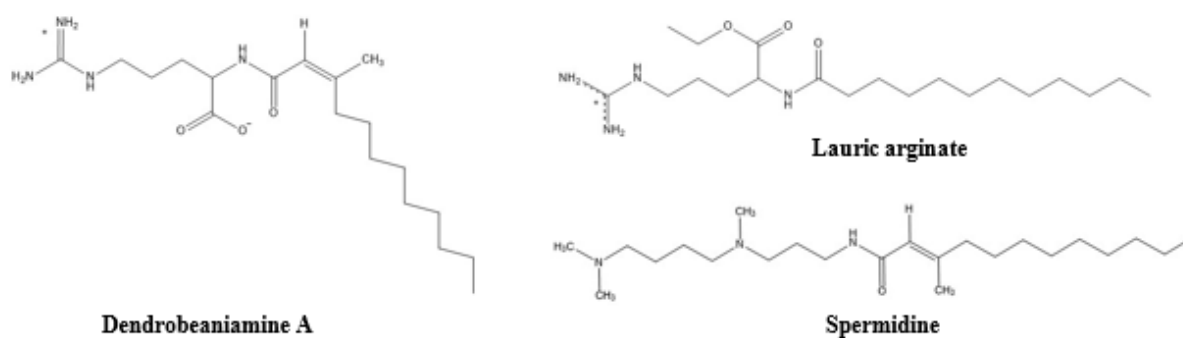
In the chemistry-guided isolation, the organic crude extract of *D. murrayana* was directly analyzed by UPLC-HR-MS. This extract was found to contain a unique and abundant peak eluting at Rt 5.7 min (**Fig 24**) with a  $m/z$  of 369.2861 ( $[M+H]^+$ ), and the calculated protonated elemental calculation was  $C_{19}H_{36}N_4O_3$ . When searching databases, the elemental composition of the target of compound did not match to any previously reported compounds and we presumed that the compound was novel and it was named dendrobeaniamine A. The isolation of dendrobeaniamine A was achieved through mass-guided fractionation by utilizing RP HPLC  $C_{18}$  (10  $\mu$ M, 10 mm  $\times$  30 mm), and fluorophenyl (5  $\mu$ m, 10 mm  $\times$  250 mm) columns. The structural elucidation of dendrobeaniamine A was done by 1D and 2D NMR experiments as described in paper 2.



**Figure 24:** ESI+ base peak intensity chromatogram of the organic extract of *D. murrayana* analyzed by UHPLC-HRESIMS. The arrow indicates the prominent peak at Rt 5.7 min.

Dendrobeaniamine A is a simple lipo-amino acid molecule also known as acyl amino acid, which contains one fatty acid and one amino acid conjugated by an amide bond. Lipo-amino acids are mostly found in bacteria and marine organisms, in particular marine invertebrates including mollusks and bryozoans. This acyl amino acid may be generated by conjugation of fatty acids and amino acids or may be metabolites of the corresponding phospholipids. The addition of amino acid into the structures of membrane lipids increases structural and chemical diversity [227]. The acyl amino acid conjugates may possibly be formed by means of excretion and detoxification of excess amount of their metabolites (e.g: ammonia- $NH_4$  and nitric oxide-NO) under abiotic stress conditions such as nitrogen saturation, low temperature and nutrient deficiency. In order to reduce abnormal concentrations of normal cellular constituents and to maintain the basic metabolism under stress circumstances, the organisms are possibly producing such compounds [228].

Acyl amino acids have been shown to be biologically active such as antibiotic, anti-inflammatory, antioxidant and cytotoxic to mammalian cells [229]. Such bioactivities are based on the degree of unsaturation in fatty acyl chains and their solubility. The structural features of dendrobeaniamine A is similar to amphipathic molecules that usually contain at least two long-chain acyl or alkyl residues in order to fulfill the basic requirement of antibacterial activity. However, dendrobeaniamine A did not exhibit antibacterial or antifungal activities at the highest concentration (135.68  $\mu\text{M}$ ) against *S. aureus*, *E. coli*, *P. aeruginosa*, *E. faecalis* or *S. agalactiae* and *C. albicans* nor against the biofilm inhibition ability of *S. epidermis*. This might be due to its mono-unsaturation (double bond) with the cis configuration, which is important for the flexibility of compound. Moreover, the zwitterionic nature of dendrobeaniamine A may result in ionic bond formation between hydroxyl group and charged guanidine group, which is probably decreasing the membrane permeability. Dendrobeaniamine A was evaluated for its ability to inhibit the release of cytokine tumor necrosis factor (TNF  $\alpha$ ) from the human acute leukemia monocyte cell line (THP-1) at 10  $\mu\text{M}$  and the compound did not show anti-inflammatory effect. Dendrobeaniamine A was also evaluated for its antioxidant effect using oxygen radical absorbance capacity (ORAC) assay and no significant activity was observed at the highest concentration. The structural features and bioactivity of dendrobeaniamine A was compared with two other structurally similar compounds, a synthetic antibacterial compound lauric arginate and cytotoxic natural product spermidine, isolated from coral *Sinularia brongersmai* (in paper 2). These three compounds differ each other by the presence and absence of specific substituents (**Fig 25**). As production of secondary metabolites is energy consuming, the natural function of dendrobeaniamine A is most likely to provide beneficial effect for the producing organisms by acting as a repellent to pathogen or predators, in competition for space or to protect against abiotic factors [230].



**Figure 25:** Dendrobeaniamine A and its structurally similar compounds lauric acid and spermidine

## 4.6. Future perspective

This work shows that Arctic marine bryozoans is a promising source for new molecules with novel structures. The compounds investigated in this thesis are new secondary metabolites, isolated from Arctic benthic marine bryozoans. The addition of these new secondary metabolites increases the structural and chemical diversity of natural products. Possible re-collection of the bryozoans from the Arctic Ocean may allow for extensive biological activity studies of the isolated compounds, or alternatively they could be chemically synthesized.

## 5. Concluding remarks

Coldwater marine bryozoans is a potential source for new secondary metabolites, and the abundance of marine bryozoans in Arctic waters is high. However, the chemical diversity of natural products varies between the species or within the species depending on geographical areas. Investigations of secondary metabolites from Coldwater marine bryozoans have been limited in numbers. This work describes the search for new natural products from Arctic bryozoans. Two new secondary metabolites were isolated from Arctic marine bryozoans using two different approaches. The bioassay-guided isolation yielded a brominated tyrosine derivative from *securiflustra securifrons* and chemistry guided isolation yielded the conjugated fatty amino acid molecule from *Dendrobeania murrayana*. Both alkaloids were inactive in the limited number of bioassays in which they were tested. The major compound securidine A in the organic crude extract of *Securiflustra securifrons* did not mask the bioactivity of the minor compounds, the securamines, and no synergistic effect was observed. The bioactivity of both novel molecules securidine A and dendrobeaniamine A should be further investigated with suitable bioassays.

The secondary metabolites isolated from marine invertebrates can be produced by the invertebrate itself, but they can also be derived either from their diet or from microorganism living within the tissues of the marine invertebrates. The chemical diversity in benthic marine invertebrates are enormous, even a single animal can be a source of many compounds [231]. Even though the ecological functions of these secondary metabolites in many cases is cryptic to us, their potential bioactivities can be exploited for drug discovery purposes.



## 6. References

1. Mayer, A.M.S.; Glaser, K.B.; Cuevas, C.; Jacobs, R.S.; Kem, W.; Little, R.D.; McIntosh, J.M.; Newman, D.J.; Potts, B.C.; Shuster, D.E. The odyssey of marine pharmaceuticals: A current pipeline perspective. *Trends Pharmacol Sci* **2010**, *31*, 255-265.
2. Cragg, G.M.; Newman, D.J. Natural products: A continuing source of novel drug leads. *Biochim Biophys Acta* **2013**, *1830*, 3670-3695.
3. Kiuru, P.; D'Auria, M.V.; Muller, C.D.; Tammela, P.; Vuorela, H.; Yli-Kauhaluoma, J. Exploring marine resources for bioactive compounds. *Planta Medica* **2014**, *80*, 1234-1246.
4. Newman, D.J.; Cragg, G.M. Natural product chemistry for drug discovery. Royal Society of Chemistry, Cambridge, UK, **2010**, 1-428.
5. Williams, B.L. Behavioral and chemical ecology of marine organisms with respect to tetrodotoxin. *Mar Drugs* **2010**, *8*, 381-398.
6. Maplestone, R.A.; Stone, M.J.; Williams, D.H. The evolutionary role of secondary metabolites - A review. *Gene* **1992**, *115*, 151-157.
7. Haslam, E. Secondary metabolism - Evolution and function: Products or processes? *Chemoecol* **1995**, *2*, 89-95.
8. Wolfender, J.L.; Marti, G.; Queiroz, E.F. Advances in techniques for profiling crude extracts and for the rapid identification of natural products: Dereplication, quality control and metabolomics. *Curr Org Chem* **2010**, *14*, 1808-1832.
9. Hay, M.E. Marine chemical ecology: What's known and what's next? *J Exp Mar Biol Ecol* **1996**, *200*, 103-134.
10. Hu, Y.; Chen, J.; Hu, G.; Yu, J.; Zhu, X.; Lin, Y.; Chen, S.; Yuan, J. Statistical research on the bioactivity of new marine natural products discovered during the 28 years from 1985 to 2012. *Mar Drugs* **2015**, *13*, 202-221.
11. Suleria, H.A.R.; Osborne, S.; Masci, P.; Gobe, G. Marine-based nutraceuticals: An innovative trend in the food and supplement industries. *Mar Drugs* **2015**, *13*, 6336-6351.
12. Simmons, T.L.; Andrianasolo, E.; McPhail, K.; Flatt, P.; Gerwick, W.H. Marine natural products as anticancer drugs. *Mol Cancer Ther* **2005**, *4*, 333-342.
13. Abad, M.; Bermejo, P. Bioactive natural products from marine sources. *Stud Nat Prod Chem* **2001**, *25*, 683-755.
14. Trepos, R.; Cervin, G.; Hellio, C.; Pavia, H.; Stensen, W.; Stensvåg, K.; Svendsen, J.S.; Haug, T.; Svenson, J. Antifouling compounds from the sub-arctic ascidian *Synoicum pulmonaria*: Synoxazolidinones A and C, pulmonarins A and B, and synthetic analogues. *J Nat Prod* **2014**, *77*, 2105-2113.
15. Dewick, P.M. Medicinal natural products: A biosynthetic approach. 3rd ed.; John Wiley & Sons, Ltd.: Chichester, UK, 2009; 1-539.
16. Proksch, P.; Edrada, R.A.; Ebel, R. Drugs from the Seas - Current status and microbiological implications. *Appl Microbiol Biotechnol* **2002**, *59*, 125-134.
17. Dias, D.A.; Sylvia, U.; Roessner, U. A historical overview of natural products in drug discovery. *Metabolites* **2012**, *2*, 303-336.
18. Guo, Z. The modification of natural products for medical use. *Acta Pharm Sin B* **2017**, *7*, 119-136.
19. Singh, S.B.; Pelaez, F. Biodiversity, chemical diversity and drug discovery. *Prog Drug Res* **2008**, *1*, 141-174.
20. Stratton, C.F.; Newman, D.J.; Tan, D.S. Cheminformatic comparison of approved drugs from natural product versus synthetic origins. *Bioorg Med Chem Lett* **2015**, *25*, 4802-4807.
21. Clardy, J.; Walsh, C. Lessons from natural molecules. *Nature* **2004**, *432*, 829-837.
22. Lahlou, M. The success of natural products in drug discovery. *Pharmacol Pharm* **2013**, *4*, 17-31.
23. Cragg, G.M.; Schepartz, S.A.; Suffness, M.; Grever, M.R. The taxol supply crisis. New NCI policies for handling the large-scale production of novel natural product anticancer and anti-HIV agents. *J Nat Prod* **1993**, *56*, 1657-1668.

24. Zheng, W.; Seletsky, B.M.; Palme, M.H.; Lydon, P.J.; Singer, L.A.; Chase, C.E.; Lemelin, C.A.; Shen, Y.; Davis, H.; Tremblay, L.; Towle, M.J.; Salvato, K.A.; Wels, B.F.; Aalfs, K.K.; Kishi, Y.; Littlefield, B.A.; Yu, M.J. Macrocyclic ketone analogues of halichondrin B. *Bioorg Med Chem Lett* **2004**, *14*, 5551-5554.
25. Cragg, G.M.; Newman, D.J. Drug discovery and development from natural products: The way forward. *11th NAPRECA Symposium Book of Proceedings* **2005**, *1*, 56-69.
26. Dabydeen, D.A.; Burnett, J.C.; Bai, R.; Verdier-Pinard, P.; Hickford, S.J.; Pettit, G.R.; Blunt, J.W.; Munro, M.H.; Gussio, R.; Hamel, E. Comparison of the activities of the truncated halichondrin B analog NSC 707389 (E7389) with those of the parent compound and a proposed binding site on tubulin. *Mol Pharmacol* **2006**, *70*, 1866-1875.
27. Altmann, K.H. Drugs from the Oceans: Marine natural products as leads for drug discovery. *Chimia (Aarau)* **2017**, *71*, 646-652.
28. Tadeusz, F.M.; Doralyn, S.D.; Sarah, L.L.; Jonel, P.S. Drug development from marine natural products. *Nat Rev Drug Discov* **2008**, *8*, 69-85.
29. Ji, H.F.; Li, X.J.; Zhang, Y.H. Natural products and drug discovery. Can thousand of medicine thousands of years of ancient medical knowledge lead us to new and powerful drug combinations in the fight against cancer and dementia?. *Euro Mol Biol Org Rep* **2009**, *10*, 194-200.
30. Newman, D.J.; Cragg, G.M.; Snader, K.M. The influence of natural products upon drug discovery. *Nat Pro Rep* **2000**, *17*, 215-234.
31. Wan, F.; Zhong, G. A medication comparison between prescriptions for fifty-two diseases and Ten-Thousands things. *Acta Med Sin* **1990**, *5*, 55-58.
32. Li, J.W.H.; Vederas, J.C. Drug discovery and natural products: End of an era or an endless frontier? *Science - New Series* **2009**, *325* 161-165.
33. Norn, S.; Kruse, P.R.; Kruse, E. History of opium poppy and morphine. *Dansk Medicin Historisk Arbog* **2005**, *33*, 171-184.
34. Kaiser, H. *Von der Pflanze zur Chemie – Die Frühgeschichte der "Rheumamittel"*. 2008; 252-262.
35. Tu, Y. Artemisinin-A gift from traditional chinese medicine to the world (Nobel Lecture). *Angewandte Chemie* **2016**, *55*, 10210-10226.
36. Borchardt, J. A short history of quinine. *Drug news & Persp* **1996**, *9*, 116-120.
37. Shen, B. A New golden age of natural products drug discovery. *Cell* **2015**, *163*, 1297-1300.
38. Fleming, A. On the Antibacterial action of cultures of a *Penicillium*, with special reference to their use in the isolation of *B. influenzae*. *Br J Exp Pathol* **1929**, *10*, 226-236.
39. Buss, A.; Cox, B.; Waigh, R. Natural products as leads for new pharmaceuticals. *Med Chem Drug Discov* **2003**, 847-900.
40. Germershausen, J.I.; Hunt, V.M.; Bostedor, R.G.; Bailey, P.J.; Karkas, J.D.; Alberts, A.W. Tissue selectivity of the cholesterol-lowering agents lovastatin, simvastatin and pravastatin in rats *in vivo*. *Biochem Biophys Res Commun* **1989**, *158*, 667-675.
41. Omura, S. Ivermectin: 25 years and still going strong. *Inter J antimicrobial agents* **2008**, *31*, 91-98.
42. Cragg, G.; Boyd, M.; Cardellina, J.; Newman, D.; Snader, K.; McCloud, T., Ethnobotany and drug discovery experience of the US National Cancer Institute: In: Chadwick DJ, Marsh J (Eds.), Ciba foundation "Ethnobotany and the search for new drugs" symposium, 185. Wiley and Sons, Chichester, UK, **1994**, 1-280.
43. Newman, D.J.; Cragg, G.M. Natural products as sources of new drugs from 1981 to 2014. *J Nat Prod* **2016**, *79*, 629-661.
44. Frank, E.K.; Guy, T.C. The evolving role of natural products in drug discovery. *Nat Rev Drug Discov* **2005**, *4*, 206-220.
45. Cheung, R.C.; Ng, T.B.; Wong, J.H. Marine peptides: Bioactivities and applications. *Mar Drugs* **2015**, *13*, 4006-4043.
46. Sipkema, D.; Franssen, M.C.; Osinga, R.; Tramper, J.; Wijffels, R.H. Marine sponges as pharmacy. *Mar Biotechnol* **2005**, *7*, 142-162.

47. Demain, A.; Zhang, J. Cephalosporin C production by *Cephalosporium acremonium* : The methionine Story. **1998**, 283-294.
48. Fenical, W. Natural products chemistry in the marine environment. *Science - New Series* **1982**, *215*, 923-928.
49. Lei, J.; Zhou, J. A Marine natural product database. *J Chem Inf Comput Sci* **2002**, *42*, 742-748.
50. Hansen, E.; Andersen, H.J. Screening for marine natural products with potential as chemotherapeutics for acute myeloid leukemia. *Curr Pharm Biotechnol* **2016**, *17*, 71-77.
51. Lam, K.S. New aspects of natural products in drug discovery. *Trends in Microbiol* **2007**, *15*, 279-289.
52. Beutler, J.A. Natural products as a foundation for drug discovery. *Curr Protoc Pharmacol* **2009**, *1*, 1-30
53. Bugni, T.S.; Harper, M.K.; McCulloch, M.W.B.; Reppart, J.; Ireland, C.M. Fractionated marine invertebrate extract libraries for drug discovery. *Molecules* **2008**, *13*, 1372-1383.
54. Trindade-Silva, A.E.; Lim-Fong, G.E.; Sharp, K.H.; Haygood, M.G. Bryostatins: Biological context and biotechnological prospects. *Curr Opin Biotechnol* **2010**, *21*, 834-842.
55. Harvey, A.L.; Ebel, E.R.; Quinn, R.J. The re-emergence of natural products for drug discovery in the genomics era. *Nat Rev Drug Discov* **2015**, *14*, 111-129.
56. Henkel, T.; Brunne, R.M.; Muller, H.; Reichel, F. Statistical investigation into the structural complementarity of natural products and synthetic compounds. *Angewandte Chemie* **1999**, *38*, 643-647.
57. Harvey, A.L. Natural products in drug discovery. *Drug Discov Today* **2008**, *13*, 894-901.
58. Kong, D.-X.; Jiang, Y.-Y.; Zhang, H.-Y., Marine natural products as sources of novel scaffolds: Achievement and concern. *Drug Discov Today* **2010**, *15*, 884-886.
59. Selzer, P.; Roth, H.-J.; Ertl, P.; Schuffenhauer, A. Complex molecules: Do they add value? *Curr Opin Chem Biol* **2005**, *9*, 310-316.
60. Keller, T.H.; Pichota, A.; Yin, Z. A practical view of 'druggability'. *Curr Opin Chem Biol* **2006**, *10*, 357-361.
61. El-Elimat, T.; Figueroa, M.; Ehrmann, B.M.; Cech, N.B.; Pearce, C.J.; Oberlies, N.H. High-resolution MS, MS/MS, and UV database of fungal secondary metabolites as a dereplication protocol for bioactive natural products. *J Nat Prod* **2013**, *76*, 1709-1716.
62. Allard, P.M.; Peresse, T.; Bisson, J.; Gindro, K.; Marcourt, L.; Pham, V.C.; Roussi, F.; Litaudon, M.; Wolfender, J.L. Integration of molecular networking and in-silico MS/MS fragmentation for natural products dereplication. *Anal Chem* **2016**, *88*, 3317-3323.
63. Wagenaar, M.M. Pre-fractionated microbial samples-The second generation natural products library at Wyeth. *Molecules* **2008**, *13*, 1406-1426.
64. Gomes, N.G.M.; Pereira, D.M.; Valentao, P.; Andrade, P.B. Hybrid MS/NMR methods on the prioritization of natural products: Applications in drug discovery. *J Pharmaceut Biomed* **2018**, *147*, 234-249.
65. Bugni, T.S.; Richards, B.; Bhoite, L.; Cimborá, D.; Harper, M.K.; Ireland, C.M. Marine natural product libraries for high-throughput screening and rapid drug discovery. *J Nat Prod* **2008**, *71*, 1095-1098.
66. Colegate, S.M.; Molyneux, R.J. Bioactive natural products: Detection, isolation, and structural determination, 2<sup>nd</sup> Edt. CRS Press, Tylor & Fransis group, Newyork, **2007**, 1-605.
67. Houghton, P.J.; Howes, M.J.; Lee, C.C.; Steventon, G. Uses and abuses of *in vitro* tests in ethnopharmacology: Visualizing an Elephant. *J Ethnopharmacol* **2007**, *110*, 391-400.
68. Hubert, J.; Nuzillard, J.-M.; Renault, J.-H. Dereplication strategies in natural product research: How many tools and methodologies behind the same concept?. *Phytochem Rev* **2017**, *16*, 55-95.
69. Ali-Khan, S.E.; Daar, A.S.; Shuman, C.; Ray, P.N.; Scherer, S.W. Whole genome scanning: Resolving clinical diagnosis and management amidst complex data. *Pediatric Res* **2009**, *66*, 357.
70. Sudek, S.; Lopanik, N.B.; Waggoner, L.E.; Hildebrand, M.; Anderson, C.; Liu, H.; Patel, A.; Sherman, D.H.; Haygood, M.G. Identification of the putative bryostatin polyketide synthase

- gene cluster from "*Candidatus Endobugula sertula*", the uncultivated microbial symbiont of the marine bryozoan *Bugula neritina*. *J Nat Prod* **2007**, *70*, 67-74.
71. Lebar, M.D.; Heimbegner, J.L.; Baker, B.J. Cold-water marine natural products. *Nat Prod Rep* **2007**, *24*, 774-797.
  72. Margulis, L.; Chapman, M.J. Kingdoms and Domains: An Illustrated Guide to the Phyla of Life on Earth. *Elsevier Science*: Burlington, USA, **2009**, 1-631.
  73. Engel, S.; Jensen, P.R.; Fenical, W. Chemical ecology of marine microbial defense. *J Chem Ecol* **2002**, *28*, 1971-1985.
  74. Gudbjarnason, S. Bioactive marine natural products. *Rit Fiskideildar* **1999**, *16*, 107-110.
  75. Kijjoa, A.; Sawangwong, P. Drugs and cosmetics from the Sea. *Mar. Drugs* **2004**, *2*, 73-82.
  76. Arizza, V. Marine biodiversity as source of new drugs. *Italian J Zoolol* **2013**, *80*, 317-318.
  77. Leal, M.C.; Puga, J.; Serôdio, J.; Gomes, N.C.M.; Calado, R.; Roberts, J.M. Trends in the discovery of new marine natural products from invertebrates over the Last two decades – Where and what are we bioprospecting? *PloS one* **2012**, *7*, 1-15
  78. Garson, M.J. Biosynthetic studies on marine natural products. *Nat Prod Rep* **1989**, 43-170.
  79. Rocha-Martin, J.; Harrington, C.; Dobson, A.D.; O'Gara, F. Emerging strategies and integrated systems microbiology technologies for biodiscovery of marine bioactive compounds. *Mar Drugs* **2014**, *12*, 3516-3559.
  80. Carr, M.H.; Neigel, J.E.; Estes, J.A.; Andelman, S.; Warner, R.R.; Largier, J.I. Comparing marine and terrestrial ecosystems: Implications for the design of coastal marine reserves. *Ecol Appl* **2003**, *13*, 90-107.
  81. Sinko, J.; Rajchard, J.; Balounova, Z.; Fikotova, L. Biologically active substances from water invertebrates: A review. *Vet Med Czech* **2012**, *57*, 177-184.
  82. Hu, G.P.; Yuan, J.; Sun, L.; She, Z.G.; Wu, J.H.; Lan, X.J.; Zhu, X.; Lin, Y.C.; Chen, S.P. Statistical research on marine natural products based on data obtained between 1985 and 2008. *Mar Drugs* **2011**, *9*, 514-525.
  83. Lindquist, N. Chemical defense of early life stages of benthic marine invertebrates. *J Chem Ecol* **2002**, *28*, 1987-2000.
  84. McClintock, J.; Baker, B.J., A review of the chemical ecology of Antarctic marine invertebrates. *Amer Zool* **1997**, *37*, 329-342.
  85. Pawlik, J.R. Marine invertebrate chemical defenses. *Chem Rev* **1993**, *93*, 1911-1922.
  86. Bakus, G.J.; Targett, N.M.; Schulte, B. Chemical ecology of marine organisms: An overview. *J Chem Ecol* **1986**, *12*, 951-987.
  87. Martins, A.; Vieira, H.; Gaspar, H.; Santos, S. Marketed marine natural products in the pharmaceutical and cosmeceutical industries: Tips for success. *Mar Drugs* **2014**, *12*, 1066-1101.
  88. Harvey, A. Strategies for discovering drugs from previously unexplored natural products. *Drug Discov Today* **2000**, *5*, 294-300
  89. Villa, F.A.; Gerwick, L. Marine natural product drug discovery: Leads for treatment of inflammation, cancer, infections, and neurological disorders. *Immunopharmacol Immunotoxicol* **2010**, *32*, 228-237.
  90. Konig, G.M.; Kehraus, S.; Seibert, S.F.; Abdel-Lateff, A.; Muller, D. Natural products from marine organisms and their associated microbes. *Chembiochem* **2006**, *7*, 229-238.
  91. Dudler, R.; Eberl, L. Interactions between bacteria and eukaryotes via small molecules. *Curr Opin Biotechnol* **2006**, *17*, 268-273.
  92. Proksch, P.; Ebel, R.; Edrada, R.A.; Wray, V.; Steube, K. Bioactive natural products from marine invertebrates and associated fungi. *Prog Mol Subcell Biol* **2003**, *37*, 117-142.
  93. Shnit-Orland, M.; Kushmaro, A. Coral mucus-associated bacteria: A possible first line of defense. *FEMS Microbiol Ecol* **2009**, *67*, 371-380.
  94. Rosenberg, E.; Koren, O.; Reshef, L.; Efrony, R.; Zilber-Rosenberg, I. The role of microorganisms in coral health, disease and evolution. *Nat Rev Microbiol* **2007**, *5*, 355.
  95. Leal, M.C.; Sheridan, C.; Osinga, R.; Dionisio, G.; Rocha, R.J.; Silva, B.; Rosa, R.; Calado, R. Marine microorganism-invertebrate assemblages: Perspectives to solve the "supply problem" in the initial steps of drug discovery. *Mar Drugs* **2014**, *12*, 3929-3952.

96. Penesyan, A.; Kjelleberg, S.; Egan, S. Development of novel drugs from marine surface associated microorganisms. *Mar Drugs* **2010**, *8*, 438-459.
97. Vijayalakshmi, S.; Ramasamy, M.S.; Muruges, S.; Murugan, A. Isolation and screening of marine associated bacteria from Tamil Nadu, Southeast coast of India for potential antibacterial activity. *Annal Microbiol* **2008**, *58*, 605-609.
98. Schmidt, S. A case for personalized medicine. *Personalized Med Coalition* **2014**, 1-68.
99. Ireland, C.M.; Durso, A.R.; Newman, R.A.; Hacker, M.P. Antineoplastic cyclic peptides from the marine tunicate *Lissoclinum patella*. *J Org Chem* **1982**, *47*, 1807-1811.
100. Sivonen, K.; Leikoski, N.; Fewer, D.P.; Jokela, J. Cyanobactins—Ribosomal cyclic peptides produced by cyanobacteria. *Appl Microbiol Biotechnol* **2010**, *86*, 1213-1225.
101. Cohen, P.; Holmes, C.F.B.; Tsukitan, Y. Okadaic acid a new probe for the study of cellular regulation. *Trends Biol Sci* **1990**, *15*, 98-102.
102. Kamat, P.K.; Rai, S.; Swarnkar, S.; Shukla, R.; Nath, C. Molecular and cellular mechanism of okadaic acid (OKA)-Induced neurotoxicity: A novel tool for Alzheimer's disease therapeutic application. *Mol Neurobiol* **2014**, *50*, 852-865.
103. Karaki, H.; Mitsui, M.; Nagase, H.; Ozaki, H.; Shibata, S.; Uemura, D. Inhibitory effect of a toxin okadaic acid, isolated from the black sponge on smooth muscle and platelets. *Br J Pharmacol* **1989**, *98*, 590-596.
104. Ten-Hage, L.; Delaunay, N.; Pichon, V.; Coute, A.; Puiseux-Dao, S.; Turquet, J. Okadaic acid production from the marine benthic dinoflagellate *Prorocentrum arenarium* (Dinophyceae) isolated from Europa Island coral reef ecosystem (SW Indian Ocean). *Toxicon* **2000**, *38*, 1043-1054.
105. An, T.; Winshell, J.; Scorzetti, G.; Fell, J.W.; Rein, K.S. Identification of okadaic acid production in the marine dinoflagellate *Prorocentrum rhathymum* from Florida Bay. *Toxicon* **2010**, *55*, 653-657.
106. Li, J.; Li, M.; Pan, J.; Liang, J.; Zhou, Y.; Wu, J. Identification of the okadaic acid-based toxin profile of a marine dinoflagellate strain *Prorocentrum lima* by LC-MS/MS and NMR spectroscopic data. *J Sep Sci* **2012**, *35*, 782-789.
107. Luesch, H.; Moore, R.E.; Paul, V.J.; Mooberry, S.L.; Corbett, T.H. Isolation of dolastatin 10 from the marine cyanobacterium *Symploca* Species VP642 and total stereochemistry and biological evaluation of its Analogue symprostatin 1. *J Nat Prod* **2001**, *64*, 907-910.
108. Harrigan, G.G.; Luesch, H.; Yoshida, W.Y.; Moore, R.E.; Nagle, D.G.; Paul, V.J.; Mooberry, S.L.; Corbett, T.H.; Valeriote, F.A. Symplostatin 1: A dolastatin 10 analogue from the marine cyanobacterium *Symploca hydroides*. *J Nat Prod* **1998**, *61*, 1076-1077.
109. Rinehart, K.L.; Holt, T.G.; Fregeau, N.L.; Stroh, J.G.; Keifer, P.A.; Sun, F.; Li, L.H.; Martin, D.G. Ecteinascidins 729, 743, 745, 759A, 759B, and 770: Potent antitumor agents from the Caribbean tunicate *Ecteinascidia turbinata*. *J Org Chem* **1990**, *55*, 4512-4515.
110. Moss, C.; Green, D.H.; Perez, B.; Velasco, A.; Henriquez, R.; McKenzie, J.D. Intracellular bacteria associated with the ascidian *Ecteinascidia turbinata* : Phylogenetic and *in situ* hybridisation analysis. *Mar Biol* **2003**, *143*, 99-110.
111. Schofield, M.M.; Jain, S.; Porat, D.; Dick, G.J.; Sherman, D.H. Identification and analysis of the bacterial endosymbiont specialized for production of the chemotherapeutic natural product ET-743. *Environ Microbiol* **2015**, *17*, 3964-3975.
112. Perez-Matos, A.E.; Rosado, W.; Govind, N.S. Bacterial diversity associated with the Caribbean tunicate *Ecteinascidia turbinata*. *Antonie Van Leeuwenhoek* **2007**, *92*, 155-164.
113. Gao, B.; Peng, C.; Yang, J.; Yi, Y.; Zhang, J.; Shi, Q. Cone Snails: A big store of conotoxins for novel drug discovery. *Toxins (Basel)* **2017**, *9*, 1-18.
114. Cuevas, C.; Francesch, A. Development of Yondelis (trabectedin, ET-743). A semisynthetic process solves the supply problem. *Nat Prod Rep* **2009**, *26*, 322-337.
115. Jimenez, C. Marine natural products in medicinal chemistry. *Med Chem Lett* **2018**, *9*, 959-961.
116. Lindequist, U. Marine-Derived pharmaceuticals - Challenges and opportunities. *Biomol Ther (Seoul)* **2016**, *24*, 561-571.

117. Eccles, R.; Meier, C.; Jawad, M.; Weinmüller, R.; Grassauer, A.; Prieschl-Grassauer, E. Efficacy and safety of an antiviral Iota-Carrageenan nasal spray: A randomized, double-blind, placebo-controlled exploratory study in volunteers with early symptoms of the common cold. *Respir Res* **2010**, *11*, 108-108.
118. Blunt, J.W.; Copp, B.R.; Keyzers, R.A.; Munro, M.H.; Prinsep, M.R. Marine natural products. *Nat Prod Rep* **2012**, *29*, 144-222.
119. Blunt, J.W.; Copp, B.R.; Keyzers, R.A.; Munro, M.H.; Prinsep, M.R. Marine natural products. *Nat Prod Rep* **2013**, *30*, 237-323.
120. Blunt, J.W.; Copp, B.R.; Keyzers, R.A.; Munro, M.H.; Prinsep, M.R. Marine natural products. *Nat Prod Rep* **2014**, *31*, 160-258.
121. Blunt, J.W.; Copp, B.R.; Keyzers, R.A.; Munro, M.H.; Prinsep, M.R. Marine natural products. *Nat Prod Rep* **2015**, *32*, 116-211.
122. Blunt, J.W.; Copp, B.R.; Keyzers, R.A.; Munro, M.H.; Prinsep, M.R. Marine natural products. *Nat Prod Rep* **2016**, *33*, 382-431.
123. Blunt, J.W.; Copp, B.R.; Keyzers, R.A.; Munro, M.H.G.; Prinsep, M.R. Marine natural products. *Nat Prod Rep* **2017**, *34*, 235-294.
124. Blunt, J.W.; Carroll, A.R.; Copp, B.R.; Davis, R.A.; Keyzers, R.A.; Prinsep, M.R. Marine natural products. *Nat Prod Rep* **2018**, *35*, 8-53.
125. Blunt, J.W.; Copp, B.R.; Hu, W.P.; Munro, M.H.; Northcote, P.T.; Prinsep, M.R. Marine natural products. *Nat Prod Rep* **2008**, *25*, 35-94.
126. Blunt, J.W.; Copp, B.R.; Hu, W.P.; Munro, M.H.; Northcote, P.T.; Prinsep, M.R. Marine natural products. *Nat Prod Rep* **2009**, *26*, 170-244.
127. Blunt, J.W.; Copp, B.R.; Munro, M.H.; Northcote, P.T.; Prinsep, M.R. Marine natural products. *Nat Prod Rep* **2010**, *27*, 165-237.
128. Blunt, J.W.; Copp, B.R.; Munro, M.H.; Northcote, P.T.; Prinsep, M.R. Marine natural products. *Nat Prod Rep* **2011**, *28*, 196-268.
129. Sharp, J.H.; Winson, M.K.; Porter, J.S. Bryozoan metabolites: An ecological perspective. *Nat Prod Rep* **2007**, *24*, 659-673.
130. Pejin, B.; Mojović, M.; Savić, A.G. Novel antitumour natural products from the phylum Bryozoa. *Biologia Serbica* **2013**, *35*, 3-14.
131. Prinsep, M.R.; Yao, B.; Nicholson, B.K.; Gordon, D.P. The pterocellins, bioactive alkaloids from the marine bryozoan *Pterocella vesiculosa*. *Phytochem Rev* **2004**, *3*, 325-331.
132. Gaudencio, S.P.; Pereira, F. Dereplication: racing to speed up the natural products discovery process. *Nat Prod Rep* **2015**, *32*, 779-810.
133. Cos, P.; Vlietinck, A.J.; Berghe, D.V.; Maes, L. Anti-infective potential of natural products: How to develop a stronger *in vitro* 'proof-of-concept'. *J Ethnopharmacol* **2006**, *106*, 290-302.
134. Zhang, H.L.; Hua, H.M.; Pei, Y.H.; Yao, X.S. Three new cytotoxic cyclic acylpeptides from marine *Bacillus* sp. *Chem pharma bull* **2004**, *52*, 1029-1030.
135. Tadesse, M.; Tabudravu, J.N.; Jaspars, M.; Strom, M.B.; Hansen, E.; Andersen, J.H.; Kristiansen, P.E.; Haug, T. The antibacterial ent-eusynstyelamide B and eusynstyelamides D, E, and F from the Arctic bryozoan *Tegella cf. spitzbergensis*. *J Nat Prod* **2011**, *74*, 837-841.
136. Ryland, J.S.; Hayward, P.J. Marine flora and fauna of the Northern United States erect Bryozoa; NMFS 99; U.S. Department of the Commerce: National Oceanic and Atmospheric Administration - Report **1991**, 1-47.
137. Ryland, J.S. Bryozoa: An introductory overview. *Denisia 16, zugleich Kataloge der OÖ. Landesmuseen Neue Serie* **2005**, *28*, 9-20.
138. Nielsen, C. Bryozoa (Ectoprocta). *Encycl Life Sci* **2007**, 1-10.
139. Bock, P.E.; Gordon, D.P. Phylum Bryozoa Ehrenberg, 1831. Zhang, Z.Q. (Ed.) Animal biodiversity: An outline of higher-level classification and survey of taxonomic richness (Addenda 2013) *Zootaxa* **2013**, *3703*, 67-74.
140. Gordon, D.P.; Smith, A.M. Bryozoans of southern New Zealand: A field identification guide. *Aquatic Environmental and Biodiversity Report* **2011**, 1-65.

141. Smith, A.M. Growth and calcification of marine bryozoans in a changing Ocean. *Biol Bull* **2014**, 226, 203–210.
142. Taylor, P.D.; Lombardi, C.; Cocito, S. Biomineralization in bryozoans: Present, past and future. *Biol Rev Camb Philos Soc* **2015**, 90, 1118-1150.
143. Fortunato, H. Bryozoans in climate and ocean acidification research: A reappraisal of an under used tool. *Reg Stud Mar Sci* **2015**, 2, 1-44.
144. Law, M. Bryozoans in Archaeology. *Archaeol* **2013**, 35, 1-16.
145. Gontar, V.; Hop, H.; Voronkov, A.Y. Diversity and distribution of Bryozoa in Kongsfjorden, Svalbard. *Pol Polar Res* **2001**, 22, 187-204.
146. Wood, A.C.L.; Probert, P.K.; Rowden, A.A.; Smith, A.M. Complex habitat generated by marine bryozoans: A review of its distribution, structure, diversity, threats and conservation. *Aquatic Conserv Mar Freshwater Ecosys* **2012**, 22, 547-563.
147. Puce, S.; Bavestrello, G.; Di Camillo, C.G.; Boero, F. Symbiotic relationships between hydroids and bryozoans. *Symbiosis* **2007**, 44, 137-143.
148. Ernst, A.; Schafer, P.; Scholz, J. Bryozoan Studies 2010. **2013**, Springer-Verlag Berlin Heidelberg 143, 1-463.
149. Atta-ur-Rahman. Studies in natural products chemistry: Bioactive natural products. Elsevier Science **2016**, 48, 1-470.
150. Okamura, B.; Partridge, J. Suspension feeding adaptations to extreme flow environments in a marine bryozoan. *Biol Bull* **1999**, 2, 205-215.
151. Ryland, J. Physiology and ecology of marine bryozoans, *Adv Mar Biol* **1977**, 14, 285-443.
152. Berning, B. Evidence for sublethal predation and regeneration among living and fossil Ascophoran bryozoans. Virginia Museum of Natural History Publication **2008**, 15, 1-7.
153. Lidgard, S. Predation on marine bryozoan colonies: Taxa, traits and trophic groups. *Mar Ecol Pro Series* **2008**, 359, 117-131.
154. Harven, C.D. Predator induced defense in a marine bryozoan. *Science - New Series* **1984**, 224, 1357-1359.
155. Lopanik, N.; Gustafson, K.R.; Lindquist, N. Structure of bryostatin 20: A symbiont-produced chemical defense for larvae of the host bryozoan, *Bugula neritina*. *J Nat Prod* **2004**, 67, 1412-1414.
156. Lindquist, N.; Hay, M.E. Palatability and chemical defense of marine invertebrate larvae. *Ecol Monographs* **1996**, 66, 431-450.
157. Carte, B.; Faulkner, D.J. Defensive metabolites from three nembrothid nudibranchs. *J Org Chem* **1983**, 48, 2314-2318.
158. Lindquist, N.; Hay, M.E.; Fenical, W. Defense of ascidians and their conspicuous larvae: Adult vs. Larval chemical defenses. *Ecol Monographs* **1992**, 62, 547-568.
159. Proksch, P. Defensive roles for secondary metabolites from marine sponges and sponge-feeding nudibranchs. *Toxicon* **1994**, 32, 639-655.
160. Santos, L.; Clavico, E.; Parra, L.; Berlinck, R.; Ferreira, A.; Paul, V.; Pereira, R. Evaluation of chemical defense and chemical diversity in the exotic bryozoan *Amathia verticillata*. *J Brazil Chem Soc* **2017**, 28, 435-442
161. Kon-ya, K.; Shimidzu, N.; Adachi, K.; Miki, W. 2, 5, 6-Tribromo-1-methylgramine, an antifouling substance from the marine bryozoan *Zoobotryon pellucidum*, *Fish Sci* **1994**, 60, 773-775.
162. Christophersen, C. Secondary metabolites from marine bryozoans. *Acta chemica Scandinavica. Series B: Org Chem Biochem* **1985**, 39, 517-529.
163. Lopanik, N.B. Chemical defensive symbioses in the marine environment. *Funct Ecol* **2014**, 28, 328-340.
164. Karagodina, N.P.; Vishnyakov, A.E.; Kotenko, O.N.; Maltseva, A.L.; Ostrovsky, A.N. Ultrastructural evidence for nutritional relationships between a marine colonial invertebrate (Bryozoa) and its bacterial symbionts. *Symbiosis* **2018**, 75, 155-164.
165. Boyle, P.J.; Maki, J.S.; Mitchell, R. Mollicute identified in novel association with aquatic invertebrate. *Curr Microbiol* **1987**, 15, 85-89.

166. Ostrovsky, A. Evolution of sexual reproduction in marine invertebrates: Example of gymnolaemate bryozoans. Springer-Verlag Berlin Heidelberg **2013**, 1-354
167. Woollacott, R.M.; Association of bacteria with bryozoan larvae. *Mar Biol* **1981**, *65*, 155-158.
168. Woollacott, R.M.; Zimmer, R.L. A. Simplified placenta-like system for the transport of extraembryonic nutrients during embryogenesis of *Bugula neritina* (Bryozoa). *J Morphol* **1975**, *147*, 355-377.
169. Weaver, H.; Cook, P.; Bock, P.; Gordon, D. Australian Bryozoa: Biology, Ecology and Natural History. CSIRO Publishing **2018**, *1*, 1-280.
170. Maltseva, A.L.; Kotenko, O.N.; Kutyumov, V.A.; Matvienko, D.A.; Shavarda, A.L.; Winson, M.K.; Ostrovsky, A.N. Novel brominated metabolites from Bryozoa: A functional analysis. *Nat Prod Res* **2017**, *31*, 1840-1848.
171. Mathew, M.; Bean, K.; Tiagueu, T.Y.; Caciula, A.; Mandoiu, I.; Zelikovsky, A.; Lopanik, N. Influence of symbiont-produced bioactive natural products on holobiont fitness in the marine bryozoan, *Bugula neritina* via protein kinase C (PKC). *J Life Oceans Coastal Waters* **2016**, *163*, 1-17.
172. Pukall, R.; Kramer, I.; Rohde, M. Microbial diversity of cultivatable bacteria associated with the North Sea bryozoan *Flustra foliacea*. *System Appl Microbiol* **2001**, *24*, 623-633.
173. Linneman, J.; Paulus, D.; Lim-Fong, G.; Lopanik, N.B. Latitudinal variation of a defensive symbiosis in the *Bugula neritina* (Bryozoa) sibling species complex. *PloS one* **2014**, *9*, 1-10.
174. Sharp, K.H.; Davidson, S.K.; Haygood, M.G. Localization of *Candidatus* Endobugula sertula and the bryostatins throughout the life cycle of the bryozoan *Bugula neritina*. *Multi J Microbiol Ecol* **2007**, *1*, 693-702.
175. Haygood, M.G.; Davidson, S.K. Small-subunit rRNA genes and in situ hybridization with oligonucleotides specific for the bacterial symbionts in the larvae of the bryozoan *Bugula neritina* and proposal of *Candidatus* Endobugula sertula. *Appl Environ Microbiol* **1997**, *63*, 4612-4616.
176. Walls, J.T.; Blackman, A.J.; Ritz, D.A. Distribution of amathamide alkaloids within single colonies of the bryozoans *Amathia wilsoni*. *J Chem Ecol* **1991**, *17*, 1871-1881.
177. Li, J.J.; Corey, E.J. Total synthesis of natural products: At the frontiers of organic chemistry. Springer Berlin Heidelberg **2013**, 1-130.
178. Yu, H.B.; Yang, F.; Li, Y.Y.; Gan, J.H.; Jiao, W.H.; Lin, H.W. Cytotoxic bryostatin derivatives from the South China Sea bryozoan *Bugula neritina*. *J Nat Prod* **2015**, *78*, 1169-1173.
179. Sun, M.-K.; Alkon, D.L. Bryostatin-1: Pharmacology and therapeutic potential as a CNS Drug. *CNS Oncol.* **2006**, *12*, 1-8.
180. Carle, J.S.; Christophersen, C. Marine alkaloids. 2. Bromo alkaloids from a marine bryozoan *Flustra foliacea*. Isolation and structure elucidation. *J Org Chem* **1980**, *45*, 1586-1589.
181. Holst, P.; Anthoni, U.; Christophersen, C.; Nielsen, P. Marine alkaloids, 15. Two alkaloids, flustramine E and debromoflustramine B, from the marine bryozoan *Flustra foliacea*. *J Nat Prod* **1994**, *57*, 997-1000.
182. Rochfort, S.J.; Moore, S.; Craft, C.; Martin, N.H.; Van Wagoner, R.M.; Wright, J.L.C. Further studies on the chemistry of the flustra alkaloids from the bryozoan *Flustra foliacea*. *J Nat Prod* **2009**, *72*, 1773-1781.
183. Carle, J.S.; Christophersen, C. Bromo-substituted physostigmine alkaloids from a marine bryozoa *Flustra foliacea*. *J Am Chem Soc* **1979**, *101*, 4012-4013.
184. Carle, J.S.; Christophersen, C. Marine alkaloids. 3. Bromo-substituted alkaloids from the marine bryozoan *Flustra foliacea*, flustramine C and flustraminol A and B. *J Org Chem* **1981**, *46*, 3440-3443.
185. Wulff, P.; Carle, J.S.; Christophersen, C. Marine alkaloids. 5. Flustramide A and 6-bromo-Nb-methyl-Nb-formyltryptamine from the marine bryozoan *Flustra foliacea*. *J Nat Prod* **1982**, *71*, 523-524.
186. Wulff, P.; Carlé, J.S.; Christophersen, C. Marine alkaloids. Part 4. A formamide, flustrabromine, from the marine bryozoan *Flustra foliacea*. *J Chem Soc* **1981**, *46*, 3440-3443



187. Wulff, P.; Carlé, J.S.; Christophersen, C. Marine alkaloids—6. The first naturally occurring bromo-substituted quinoline from *Flustra foliacea*. *Comp Biochem Mol Biol* **1982**, *71*, 525-526.
188. Sjöblom, T.; Bohlin, L.; Christophersen, C. Studies of swedish marine organisms. II. Muscle-relaxant alkaloids from the marine bryozoan *Flustra foliacea*. *Acta Pharm Suec* **1983**, *20*, 415-418.
189. Laycock, M.V.; Wright, J.I.C.; Findlay, A.J.; Patil, A.D. New Physostigmine related bromoalkaloids from the marine bryozoans *Flustra foliacea*. *Can J Chem* **1986**, *64*, 1312-1316.
191. Wright, J.L. A new antibiotic from the marine bryozoan *Flustra foliacea*. *J Nat Prod* **1984**, *47*, 893-895.
192. Carté, B.; Faulkner, D.J. Role of secondary metabolites in feeding associations between a predatory nudibranch, two grazing nudibranchs, and a bryozoan. *J Chem Ecol* **1986**, *12*, 795-804.
193. Carbone, M.; Irace, C.; Costagliola, F.; Castelluccio, F.; Villani, G.; Calado, G.; Padula, V.; Cimino, G.; Lucas Cervera, J.; Santamaria, R.; Gavagnin, M. A new cytotoxic tambjamine alkaloid from the Azorean nudibranch *Tambja ceutae*. *Bioorg Med Chem Lett* **2010**, *20*, 2668-2670.
194. Anthoni, U.; Nielsen, P.H.; Pereira, M.; Christophersen, C. Bryozoan secondary metabolites: A chemotaxonomical challenge. *Comp Biochem Physiol* **1990**, *96B*, 431-437.
195. Ashley Franks; Peter Haywood; Carola Holmström; Suhelen Egan; Kjelleberg, S.; Kumar, N. Isolation and structure elucidation of a novel yellow pigment from the marine bacterium *Pseudoalteromonas tunicata*. *Molecules* **2005**, *10*, 1286-1291.
196. Pinkerton, D.M.; Banwell, M.G.; Willis, A.C. Total Syntheses of Tambjamins C, E, F, G, H, I and J, BE-18591, and a related alkaloid from the marine bacterium *Pseudoalteromonas tunicata*. *Org Lett* **2007**, *9*, 5127-5130.
197. Rahbaek, L.; Anthoni, U.; Christophersen, G.; Nielsen, P.H.; Petersen, B.O. Marine alkaloids. 18. Securamines and securines, halogenated indole-imidazole alkaloids from the marine bryozoan *Securiflustra securifrons*. *J Org Chem* **1996**, *61*, 887-889.
198. Rahbæk, L.; Christophersen, C. Marine alkaloids. 19. Three new alkaloids, securamines E-G, from the marine bryozoan *Securiflustra securifrons*. *J Nat Prod* **1997**, *60*, 175-177.
199. Hansen, K.O.; Isaksson, J.; Bayer, A.; Johansen, J.A.; Andersen, J.H.; Hansen, E. Securamine derivatives from the Arctic bryozoan *Securiflustra securifrons*. *J Nat Prod* **2017**, *80*, 3276-3283.
200. Yao, B.; Prinsep, M.R.; Nicholson, B.K.; Gordon, D.P. The pterocellins, novel bioactive alkaloids from the marine bryozoan *Pterocella vesiculosa*. *J Nat Prod* **2003**, *66*, 1074-1077.
201. Wang, A.T.; Prinsep, M.R.; Martinus, R.D. Pterocellin A isolated from marine bryozoan *Pterocella vesiculosa* is cytotoxic to human HeLa cells via mitochondrial apoptotic processes. *SpringerPlus* **2016**, *5*, 1-11.
202. Dennis J. Milanowski, K.R.G., James A. Kelley and James B. McMahon. Caulibugulones A-F, novel cytotoxic isoquinoline quinones and iminoquinones from the marine bryozoan *Caulibugula intermis*. *J Nat Prod* **2004**, *67*, 70-73.
203. Ojika, M.; Yoshino, G.; Sakagami, Y. Novel Ceramide 1-Sulfates, potent DNA topoisomerase I inhibitors isolated from the Bryozoa *Watersipora cucullata*. *Tetrahedon Lett* **1997**, 4235-4238.
204. Tian, X.R.; Tang, H.F.; Xiao Lin Tian; Jia Jun Hu; Huang, L.L.; Gustafson, K.R. Review of bioactive secondary metabolites from marine bryozoans in the progress of new drugs discovery. *Future Med Chem* **2018**, 1-18.
205. Tian, X.R.; Tang, H.F.; Li, Y.S.; Lin, H.W.; Chen, X.L.; Ma, N.; Yao, M.N.; Zhang, P.H. New cytotoxic oxygenated sterols from the marine bryozoan *Cryptosula pallasiana*. *Mar Drugs* **2011**, *9*, 162-183.
206. Yu, C.M. Murrayanolide an unusual tetracyclic tetrapenoid lactone from marine bryozoan *Dedrabeania murrayana*. *J Nat Prod* **1995**, *58*, 1978-1982.
207. Tian, X.R.; Tang, H.F.; Li, Y.S.; Lin, H.W.; Ma, N.; Zhang, W. Sterols from marine bryozoan *Bugula neritina*. *Biochem Syst Ecol* **2010**, *38*, 435-437.
208. Yang, F.; Zhang, H.-J.; Liu, X.-F.; Chen, W.-S.; Tang, H.-F.; Lin, H.-W. Oxygenated steroids from marine bryozoan *Biflustra grandicella*. *Biochem Systemat Ecol* **2009**, *37*, 686-689.

209. Kerr, R.G.; Vicchiarelli, R.; Kerr, S.S. Identification and biosynthetic origins of sterols in the marine bryozoan *Bugula neritina*. *J Nat Prod* **1999**, *62*, 468-470.
210. Sasidharan, S.; Chen, Y.; Saravanan, D.; Sundram, K.; Latha, L., Extraction, isolation and characterization of bioactive compounds from plants' extracts. *Afr J Tradit Comp Alt Med* **2011**, *8*, 1-10.
211. Butler, A.D.; Butler, M.S. Natural product chemistry for drug discovery. Royal Society of Chemistry **2010**, *18*, 1-440
212. Zhang, Q.W.; Lin, L.G.; Ye, W.C. Techniques for extraction and isolation of natural products: A comprehensive review. *Chin Med* **2018**, *13*, 1-26.
213. Gross, J.H. Mass spectrometry 2<sup>nd</sup> Ed. Springer, Verlag-Berlin Heidelberg **2010**, *2*, 1-733.
214. Glauser, G.; Veyrat, N.; Rochat, B.; Wolfender, J.L.; Turlings, T.C. Ultra-high pressure liquid chromatography-mass spectrometry for plant metabolomics: A systematic comparison of high-resolution quadrupole-time-of-flight and single stage Orbitrap mass spectrometers. *J Chromatogr A* **2013**, *1292*, 151-159.
215. Wolfender, J.L.; Marti, G.; Thomas, A.; Bertrand, S. Current approaches and challenges for the metabolite profiling of complex natural extracts. *J Chromatogr A* **2015**, *1382*, 136-164.
216. L.James, T. Fundamentals of NMR, *Chem Inform* **1998**, 1-31.
217. K. McClure, C. Structural chemistry using NMR spectroscopy. *Org Molecules*, **1999**, 2234-2245.
218. Gontar, V.I.; Denisenko, N.V. Arctic Ocean Bryozoa *The Arctic Seas*, **1989**, 341-371.
219. Soldatou, S.; Baker, B.J. Cold-water marine natural products, 2006 to 2016. *Nat Prod Rep* **2017**, *34*, 585-626.
220. Svenson, J. MabCent: Arctic marine bioprospecting in Norway. *Fundam Perspect Nat Prod Res* **2013**, *12*, 567-578.
221. Pettit, G.R.; Herald, C.L.; Doubek, D.L.; Herald, D.L.; Arnold, E.; Clardy, J. Isolation and structure of bryostatin 1. *J Amer Chem Soc* **1982**, *104*, 6846-6848.
222. Wender, P.A.; Hardman, C.T.; Ho, S.; Jeffreys, M.S.; Maclaren, J.K.; Quiroz, R.V.; Ryckbosch, S.M.; Shimizu, A.J.; Sloane, J.L.; Stevens, M.C. Scalable synthesis of bryostatin 1 and analogs, adjuvant leads against latent HIV. *Science (New York, N.Y.)* **2017**, *358*, 218-223.
223. Mendola, D. Aquaculture of three phyla of marine invertebrates to yield bioactive metabolites: Process developments and economics. *Biomol Eng* **2003**, *20*, 441-458.
224. Cimino, G.; De Rosa, S.; De Stefano, S.; Mazzarella, L.; Puliti, R.; Sodano, G. Isolation and X-ray crystal structure of a novel bromo-compound from two marine sponges. *Tetrahedron Lett* **1982**, *23*, 767-768.
225. Meijer, L.; Thunnissen, A.; White, A.; Garnier, M.; Nikolic, M.; Tsai, L.H.; Walter, J.; Cleverley, K.; Salinas, P.; Wu, Y.Z.; Biernat, J.; Mandelkow, E.M.; Kim, S.H.; Pettit, G. Inhibition of cyclin-dependent kinases, GSK-3 $\beta$  and CK1 by hymenialdisine, a marine sponge constituent. *Chem Biol* **2000**, *7*, 51-63.
226. Morris, B.D.; Prinsep, M.R. Amathaspiramides A–F, novel brominated alkaloids from the marine bryozoan *Amathia wilsoni*. *J Nat Pro* **1999**, *62*, 688-693.
227. Blackman, A.J.; Walls, J.T. Bryozoan Secondary Metabolites and their Chemical Ecology In *Stud Nat Prod Chem*, Atta ur, R., Ed. Elsevier, **1995**, 73-112.
228. Inui, T.; Wang, Y.; Pro, S.M.; Franzblau, S.G.; Pauli, G.F. Unbiased evaluation of bioactive secondary metabolites in complex matrices. *Fitoterapia* **2012**, *83*, 1218-1225.
229. Geiger, O.; Silva, G.N.; Lopez-Lara, I.M.; Sohlenkamp, C. Amino acid-containing membrane lipids in bacteria. *Prog Lipid Res* **2010**, *49*, 46-60.
230. Barnathan, G. Non-methylene-interrupted fatty acids from marine invertebrates: Occurrence, characterization and biological properties. *Biochimie* **2009**, *91*, 671-678.
231. Farrell, E.K.; Merkler, D.J. Biosynthesis, degradation and pharmacological importance of the fatty acid amides. *Drug discov today* **2008**, *13*, 558-568.
232. Haslam, E. Secondary metabolism – fact and fiction. *Nat Prod Rep* **1986**, *3*, 217-249.
233. Fattorusso, E.; Gerwick, W.H.; Tagliatalata-Scafati, O. Handbook of marine natural products. Springer-Verlag Berlin Heidelberg **2012**, 1-400.

## Paper I

Article

# A Novel Brominated Alkaloid Securidine A, Isolated from the Marine Bryozoan *Securiflustra securifrons*

Priyanka Michael <sup>1,\*</sup>, Kine Ø. Hansen <sup>1,\*</sup> , Johan Isaksson <sup>2</sup>, Jeanette H. Andersen <sup>1</sup>  and Espen Hansen <sup>1</sup>

<sup>1</sup> MARBIO, UiT–The Arctic University of Norway, Breivika, Tromsø N-9037, Norway; jeanette.h.andersen@uit.no (J.H.A.); espen.hansen@uit.no (E.H.)

<sup>2</sup> Department of Chemistry, UiT–The Arctic University of Norway, Breivika, Tromsø N-9037, Norway; johan.isaksson@uit.no

\* Correspondence: raja.p.siranjeevi@uit.no (P.M.); kine.o.hanssen@uit.no (K.Ø.H.); Tel.: +47-77649268 (P.M.); +47-77649272 (K.Ø.H.)

† These authors contributed equally to this work.

Received: 20 June 2017; Accepted: 17 July 2017; Published: 23 July 2017

**Abstract:** A novel brominated alkaloid, Securidine A, was isolated from the cold water marine bryozoan *Securiflustra securifrons*. Securidine A was isolated using semi-preparative HPLC, and the structure was elucidated by spectroscopic methods. The isolated Securidine A was tested for cytotoxic, antibacterial, and anti-diabetic activities as well as for its potential for inhibition of biofilm formation. No significant biological activity was observed in the applied bioassays, thus expanded bioactivity profiling is required, in order to reveal any potential applications for Securidine A.

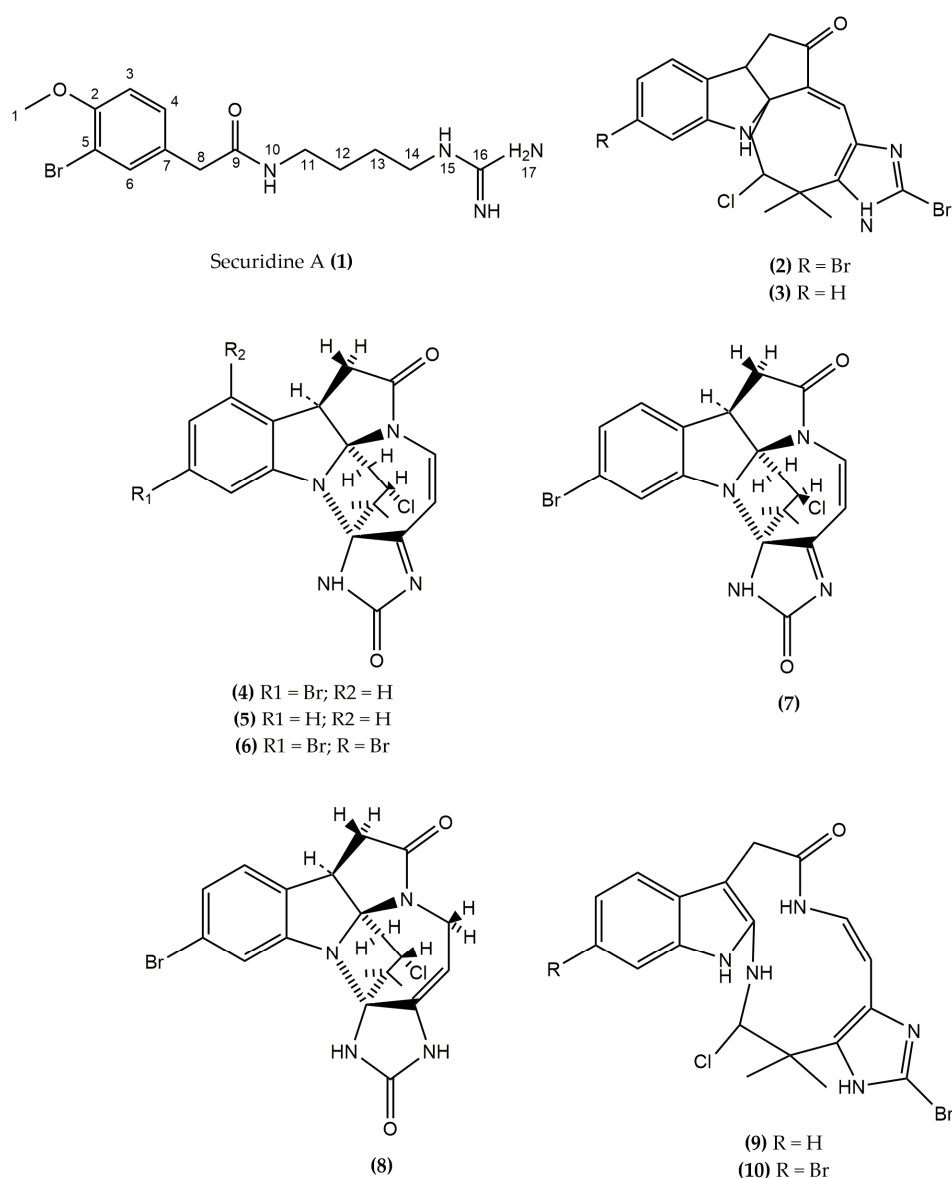
**Keywords:** secondary metabolites; marine invertebrates; marine bryozoans; *Securiflustra securifrons*; Securidine A; biological activity

## 1. Introduction

Marine organisms are considered to be a rich source for natural products, and currently almost 50,000 marine natural products are reported in the Dictionary of Marine Natural Products [1]. A statistical analysis of marine natural products discovered between 1985 and 2008 estimates that approximately 75% of the compounds are isolated from sessile and soft-bodied invertebrates including sponges, ascidians, cnidarians, mollusks and bryozoans [2,3]. In order to protect themselves from predators and to compete for space and food, many invertebrates have evolved the ability to produce secondary metabolites as a chemical defense, which increase their ability to survive, grow, and reproduce [4,5]. Bryozoans, or moss animals, are aquatic invertebrates that belong to the phylum Bryozoa (Polyzoa). They are sedentary and filter feeders. These colonial organisms consist of tiny intercommunicating individuals called zooids [6]. Bryozoans are widely distributed in tropical and temperate marine waters [7], and are common fouling organisms on marine substrates [6]. The phylum consists of 3 classes, 4 orders, 187 families, and 808 genera, and approximately 8000 species are described, most of them are observed in marine habitats [8,9]. Marine bryozoans are known to produce a significant number of biologically active secondary metabolites, including macrolides, alkaloids, sterols, and heteroatom-containing compounds [3,10] that possess antitumor [11], antibacterial [12,13], and muscle relaxant activities [14]. The well-known bioactive compound bryostatin 1 is a macrolide isolated from the marine bryozoan *Bugula neritina*, and it is proven to be an antineoplastic agent [15]. Secondary metabolites isolated from marine bryozoans have been extensively reviewed [6,8,16,17].

In the present study, we isolated the novel mono brominated tyrosine derivative Securidine A (**1**) from the marine bryozoan *Securiflustra securifrons*. *S. securifrons* (Pallas, 1766) is a temperate and subtidal species abundant in the North Sea [18,19], and the encrusting basal portion of the

colonies are attached to hard substrates such as stones and shells. In previous reports, seven halogenated indole-imidazole alkaloids, Securamines A–G and Securines A and B (obtained by dissolving Securamines A and B in DMSO-*d*<sub>6</sub>), have been isolated from *S. securifrons*, but no biological activities were recorded for any of these compounds. The halogenated Securamines A–G (Figure 1) differ from each other by the presence and absence of a bromine substitution or a number of bromine substitutions in the benzene ring. [20,21]. These compounds are structurally similar to chartellines A–C and chartellamides A and B, isolated from another marine bryozoan *Chartella papyracea*. Both species belong to the Flustridae family (Order: Cheilostomata). Many of the Cheilostome bryozoans including *S. securifrons*, *C. papyracea*, and *Flustra foliacea* are producing indole alkaloids and brominated alkaloids [12,20–32]. However, the isolated new brominated alkaloid, Securidine A (1) is a novel structure (Figure 1), which is not structurally similar to any other listed compounds of *S. securifrons*.



**Figure 1.** Structure of novel compound Securidine A (1), Securamine A–G (2–8), and Securines A and B (9–10).

The current paper describes the isolation of new compound Securidine A (1), its structural characterization and potential biological activities were also investigated.

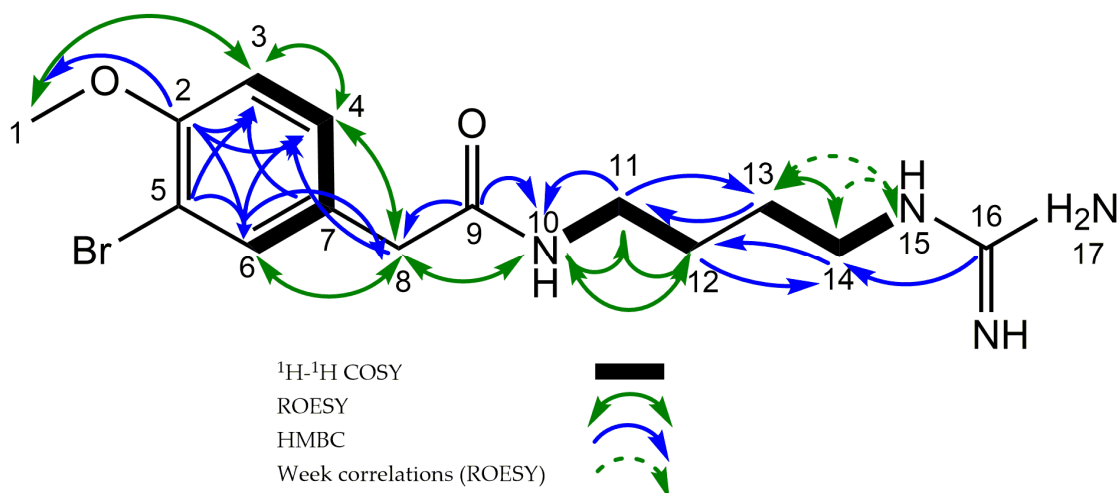
## 2. Results and Discussion

The marine bryozoan *S. securifrons* was collected in April 2014 in the North Sea. Securidine A (**1**) was isolated from the aqueous extract of *S. securifrons* through stepwise fractionation. The lyophilized animal material was ground and extracted with ultrapure water. The freeze-dried aqueous extract was pre-fractionated using column chromatography with a Biotage SP24 HPFC flash purification system. The extract was eluted with a gradient of H<sub>2</sub>O/CH<sub>3</sub>OH/CH<sub>3</sub>-CO-CH<sub>3</sub> and the fractions were assayed for cytotoxicity against melanoma (A2058) and colon adenocarcinoma (HT29) cell lines using an MTS based anticancer assay. Flash fractions four and five showed cytotoxic activity. UPLC-HR-MS analysis of these fractions, followed by isotopic pattern examination of the eluting compounds, revealed the presence of a mono brominated compound. For the isolation, the aqueous extract was injected onto semi-preparative RP-HPLC C<sub>18</sub> column and Securidine A (**1**) was eluted with a 10 minutes gradient, changing from 10% to 40% CH<sub>3</sub>CN over 10 minutes. For the second purification step, a Phenyl-Hexyl prep HPLC column was used with a 10 min gradient, changing from 10% to 34% CH<sub>3</sub>CN.

The HR-MS analysis suggested that Securidine A (**1**) contained a bromine. The molecular formula was determined to be C<sub>14</sub>H<sub>21</sub>BrN<sub>4</sub>O<sub>2</sub>, corresponding to the protonated molecular peak at *m/z* 357.0858 ([M + H]<sup>+</sup>, calculated *m/z* 357.0926), suggesting six degrees of unsaturation. A database search indicated that the isolated compound was novel, and its structure was solved based on a number of 1D and 2D NMR experiments.

Interpretation of the available 1D <sup>1</sup>H (presat, 1DNOE and excitation sculpting), 1D <sup>13</sup>C, HMBC, ME-HSQC, H2BC, COSY, and ROESY (Supplementary materials Figures S1 to S6) led to an unambiguous structural elucidation of **1**. Examination and comparison of the 1D <sup>13</sup>C, HSQC, and HMBC showed that **1** had 14 carbons consisting of one methyl group, five methylenes, three methines, and five quaternary carbon atoms. Two <sup>1</sup>H resonances, H-10 and H-15, were identified as NH groups based on the absence of any <sup>1</sup>J<sub>CH</sub>, broadened line widths and deshielded chemical shifts. Three methines indicated the presence of a disubstituted phenyl ring attached to the main chain. The methyl group protons (δ<sub>H</sub> 3.84) showed HMBC correlation to the quaternary C-2 (δ<sub>C</sub> 156.2) as well as ROESY correlation to the H-3 (δ<sub>H</sub> 6.96) methine proton. The relatively deshielded chemical shift value of the methyl protons (δ<sub>H</sub> 3.84) was assigned as the protons of a methoxy group. The high chemical shift value of C-2 (δ<sub>C</sub> 156.2) further confirmed this. COSY and ROESY correlations between H-3 (δ<sub>H</sub> 6.96) and H-4 (δ<sub>H</sub> 7.22) as well as a shared coupling constant of 8.6 between the two, places C-3 and C-4 next to each other. Additionally, the H-3 methine showed HMBC correlation to a halogenated quaternary carbon (C-5, δ<sub>C</sub> 112.2), the quaternary C-7, (δ<sub>C</sub> 130.5) as well as to the final methine carbon (C-6, δ<sub>C</sub> 134.5). The distinction between C-7 and C-5 was made based on their chemical shift values and a <sup>2</sup>J<sub>CH</sub> from C-5 to H-6, which is commonly observed from halogenated carbons but not from carbons in phenyl rings further away from heteroatoms. The H-8 (δ<sub>H</sub> 3.41) methylene showed ROESY and HMBC correlations to the protons and carbons in position 4 (δ<sub>H</sub> 7.22, δ<sub>C</sub> 130.2) and 6 (δ<sub>H</sub> 7.47, δ<sub>C</sub> 134.5), placing it in ortho position to C-4 and C-6 in the phenyl ring. The phenyl group was thus methoxy-substituted in the para position and brominated in the meta position, while and the main chain of the molecule was attached to C-7. The H-8 (δ<sub>H</sub> 3.41) protons further showed a HMBC correlation to a deshielded quaternary carbon (C-9, δ<sub>C</sub> 173.7), characteristic for a carbonyl carbon. HMBC correlations were observed to H-10 (δ<sub>H</sub> 8.20) from C-9 and to H-10 from C-11 (δ<sub>C</sub> 39.8). COSY and ROESY correlations were observed between the methylene groups in the 11 (δ<sub>H</sub> 3.20, δ<sub>C</sub> 39.8) and 12 positions (δ<sub>H</sub> 1.56, δ<sub>C</sub> 27.5). The same correlations were observed between the methylene groups in position 13 (δ<sub>H</sub> 1.55, δ<sub>C</sub> 27.0) and 14 (δ<sub>H</sub> 3.16, δ<sub>C</sub> 42.0). The methylene groups in the 12 and 13 position were near isochronous, but could be distinguished by their respective couplings to H-11 and H-14 in H2BC and COSY. H-14 further correlated with the quaternary C-16 (δ<sub>C</sub> 158.8) in HMBC spectra. H-13 (δ<sub>H</sub> 1.55) and H-14 (δ<sub>H</sub> 3.16) both showed ROESY correlations to H-15 (δ<sub>H</sub> 7.57). This, in addition to a COSY correlation between H-14 and H-15, places a NH-group in the 15 position. Thus, the remaining part of the chemical formula was N<sub>2</sub>H<sub>3</sub>, leaving the only possible structural solution to be the attachment of an NH- and an NH<sub>2</sub>- group to C-16. The deshielded shift value of C-16 (δ<sub>C</sub> 158.8)

was in good agreement with this conclusion (Table 1). Selected 2D correlations utilized in determining the structure of **1** are shown in Figure 2. The compound was named Securidine A.



**Figure 2.** Key HMBC, ME-HSQC, H2BC, COSY, and ROESY correlations of Securidine A (**1**).

**Table 1.** NMR spectroscopic data <sup>a</sup> (600 MHz, methanol-*d*<sub>3</sub>).

Position	$\delta_{\text{C}}$ , Type	$\delta_{\text{H}}$ (J in Hz)	COSY	$^1\text{H}$ , $^{13}\text{C}$ -HMBC <sup>b</sup>	$^1\text{H}$ , $^{13}\text{C}$ H2BC	ROESY
1	56.6, CH <sub>3</sub>	3.84, s		2		3
2	156.2, C					
3	113.1, CH	6.96, d (8.6)	4	2,5,7	4	1,4
4	130.2, CH	7.22, dd (8.6, 2.3)	3,6	2,3,6,8	3	3,8
5	112.2, C					
6	134.5, CH	7.47, d (2.3)	4	2,4,5,8		8
7	130.5, C					
8	42.4, CH <sub>2</sub>	3.41, s		4,6,9		4,6,10
9	173.7, C					
10		8.20, s	11	9,11	11	8,11,12 <sup>w</sup>
11	39.8, CH <sub>2</sub>	3.20, q (6.4)	10,12	9,(12/13) <sup>d</sup>	12	10,12
12	27.5, CH <sub>2</sub>	1.56, m <sup>c</sup>	11	(11/14) <sup>d</sup>	11	10 <sup>w</sup> ,11
13	27.0, CH <sub>2</sub>	1.55, m <sup>c</sup>	14	(11/14) <sup>d</sup>	14	14,15 <sup>w</sup>
14	42.0, CH <sub>2</sub>	3.16, m <sup>c</sup>	13,15	16,(12/13) <sup>d</sup>	13	13,15 <sup>w</sup>
15		7.57, s	14		14	13 <sup>w</sup> ,14 <sup>w</sup>
16	158.8, C					

<sup>a</sup>  $^1\text{H}$  1D,  $^{13}\text{C}$ ,  $^1\text{H}$ ,  $^1\text{H}$ -COSY,  $^1\text{H}$ ,  $^{13}\text{C}$ -HMBC (full and band selective) spectra are included in the supplementary data, Figures S1–S6 (Supplementary materials). <sup>b</sup>  $^1\text{H}$  1D,  $^{13}\text{C}$ -HMBC correlations are from the proton(s) stated to the indicated carbon; <sup>c</sup> Overlapping and/or broadened peaks impeding complete multiplet analysis. Chemical shift extracted from  $^1\text{H}$ ,  $^{13}\text{C}$ -HSQC,  $^1\text{H}$ ,  $^{13}\text{C}$ -HMBC and/or  $^1\text{H}$ ,  $^{13}\text{C}$ -H2BC; <sup>d</sup> ambiguous correlations in HMBC, C12 and C13 assignment based on H2BC correlations (Figure S4); <sup>w</sup> Weak correlations.

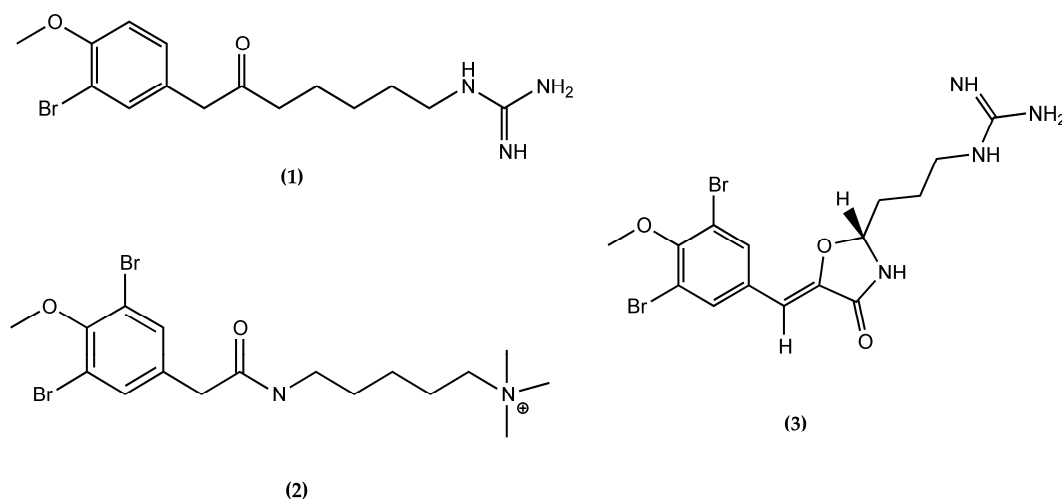
### Bioactivity

The pure Securidine A (**1**) was evaluated for its biological activity in a selection of bioassays including anti-cancer and anti-bacterial activity, inhibition of protein tyrosine phosphatase 1B (PTP-1B) for anti-diabetic activity, as well as for inhibition of biofilm formation.

Securidine A (**1**) was assessed for its cytotoxicity against three cancer cell lines (A2058 melanoma, HT29 colon adenocarcinoma and MCF7 breast carcinoma) by the MTS method, since flash fractions of the extract from *S. securifrons* showed anticancer activity against A2058 melanoma and HT29 colon adenocarcinoma cancer cell lines in the MabCent screening program [33]. However, the isolated compound, Securidine A (**1**), did not show any significant activity against the cancer cell lines at 50  $\mu\text{M}$  (17.87  $\mu\text{g}/\text{mL}$ ) or 100  $\mu\text{M}$  (37.73  $\mu\text{g}/\text{mL}$ ). Securidine A (**1**) was also tested for its antibacterial

activity, and no activity was seen against *Staphylococcus aureus*, *Escherichia coli*, *Enterococcus faecalis*, *Pseudomonas aeruginosa*, or *Streptococcus agalactiae*.

Securidine A (1) is a brominated tyrosine derivative. It is structurally related to two other brominated tyrosine derivatives, Pulmonarin B (2) and Synoxazolidinone B (3) (Figure 3), both isolated from the sub-Arctic ascidian *Synoicum pulmonaria* [34,35]. Pulmonarin B (2) contains a quaternary ammonium group in the side-chain instead of the guanidine group of Securidine A (1) and Pulmonarin B (2) did not have any antibiotic or cytotoxic activity. Both Securidine A (1) and Synoxazolidinone B (3) have a guanidine group in the side chain, but Synoxazolidinone B (3) has a central 4-oxazolidinone core, linking a di-brominated tyrosine derivative to an arginine [36]. Synoxazolidinone B (3) is active against the Gram-positive bacteria, methicillin resistant *S. aureus*. Macherla et al. suggested that a 4-oxazolidinone core is a good pharmacophore for antibacterial activity [36]. The difference between Securidine A (1) and Synoxazolidinone B (3) in activity against bacteria might thus be explained by the lack of a central 4-oxazolidinone core in Securidine A (1). Moreover, most of the antimicrobial peptides or alkaloids are amphipathic molecules, including Synoxazolidinone B, which displays two cationic groups and two bulky lipophilic groups in order to fulfill the structural requirements of antibacterial activity [37–39]. A study of the pharmacophore of small antibacterial peptides demonstrated that one cationic group as well as a minimum of two bulky groups were required for activity against Gram-positive staphylococci [40].



**Figure 3.** The structurally related compounds Securidine A (1), Pulmonarin (2), and Synoxazolidinone B (3).

The effect of Securidine A (1) against PTP-1B was also examined, since PTP-1B is regarded as a promising target for the treatment of diabetes [41]. However, no inhibition of PTP-1B was observed at 50  $\mu\text{M}$  or 100  $\mu\text{M}$ . Many potent antifouling compounds are brominated tyrosine derivatives that have cationic guanidine or guanidine-like groups [42]. Nevertheless, no inhibition of biofilm formation by *Staphylococcus epidermidis* was found at 100  $\mu\text{M}$ .

### 3. Materials and Methods

#### 3.1. Animal Material

The marine bryozoan *Securiflustra securifrons* (Pallas, 1766) was collected by an Agassiz trawl at 73 m depth from west Spitzbergen (71.0759° N, 24.4355° E) in April 2014. The fresh sample weighed 336.01 g and was frozen immediately at  $-23\text{ }^{\circ}\text{C}$ . The specimen was identified by Norwegian marine biobank Marbank (Institute of Marine Research, Tromsø, Norway) and they have a taxonomical reference sample in their collection. The sample was stored at  $-23\text{ }^{\circ}\text{C}$  until further processing.



### 3.2. Extraction

The lyophilized animal material was ground and extracted twice with ultrapure water (Milli-Q; Millipore, Billerica, MA, USA) at 4 °C for 24 h in darkness. After centrifugation (4000 rpm at 5 °C for 30 min), the supernatants were pooled and reduced under reduced pressure at 40 °C, yielding 24.78 g of aqueous extract. The remaining pellet was freeze-dried and extracted twice with 1:1 *v/v* of dichloromethane (Merck, Darmstadt, Germany) and methanol (MeOH; Sigma-Aldrich, Steinheim, Germany) at 4 °C. The combined organic extract was subsequently filtered through a Whatman No. 3 filter paper (Little Chalfont, UK) and concentrated under reduced pressure, affording 5.13 g of organic extract. Both extracts were stored at −23 °C until further use. Aqueous extract was used for isolation of Securidine A (**1**), in order to avoid including lower polarity molecules in the purification process.

### 3.3. Isolation and Purification of Compound **1**

An aliquot of the lyophilized aqueous extract (1.5 g) was mixed with 90% MeOH (6–8 mL), cooled to 4 °C, and centrifuged at 4000 rpm and 4 °C, in order to precipitate salt. The supernatant was mixed with 3.0 g resin (Dianon ®HP-20, Supelco Analytical, Bellefonte, PA, USA) and the mixture was dried by SpeedVac. The dried resin loaded with the aqueous extract was deposited on top of a column pre-packed with 6.5 g HP20SS, and the extract eluted from the column using a gradient of H<sub>2</sub>O/CH<sub>3</sub>OH/CH<sub>3</sub>COCH<sub>3</sub>. The pre-fractionation was performed using a Biotage SP4 chromatography HPFC flash purification system (Biotage, Charlottesville, NA, USA), resulting in eight fractions. These eight fractions were assayed for cytotoxicity against A2058 melanoma and HT29 colon adenocarcinoma cell lines using the MTS based anticancer assay. Fractions four and five showed cytotoxic activity and these active fractions were de-replicated using HR-MS. Securidine A (**1**) was isolated directly from the aqueous extract by mass guided prep-HPLC.

Isolation of Securidine A (**1**) was performed by a Waters HPLC purification system. The system was composed of a 600 pump, a 2996 photodiode array UV detector, a 3100 mass detector and a 2767 sample manager (Milford, MA, USA). The system was controlled with Waters MassLynx version 4.1 and the FractionLynx application manager. The mass of Securidine A (**1**) (*m/z* 356.2520) was used as the collection trigger. The aqueous extract was injected onto a Waters Xterra RP18 (10 mm × 300 mm, 10 μm) HPLC column. Securidine A (**1**) was eluted with a 10 min with a gradient from 10% to 40% CH<sub>3</sub>CN (Chromasolv; Sigma-Aldrich) in ultrapure water, both containing 0.1% formic acid (Pro-analysis, Merck), and the flow rate was 6 mL/min. Further purification was done by Waters Phenyl-Hexyl Prep (10 mm × 250 mm, 5 μm) HPLC column with a gradient from 10% to 34% of CH<sub>3</sub>CN (Chromasolv; Sigma-Aldrich) in ultrapure water with a 10 min and the flow rate of 6 mL/min.

### 3.4. Structure Determination

UPLC-HR-MS analysis and NMR were used to confirm the structure of Securidine A (**1**). UPLC-HR-MS analysis was performed on an Acquity UPLC and a LCT premier Time-of-Fight MS using ESI<sup>+</sup> ionization (Waters). MassLynx version 4.1 was used to process the MS data. The NMR experiments were acquired on a Bruker Avance III HD spectrometer operating at 599.90 MHz for protons, equipped with an inverse detected cryo-probe enhanced for <sup>1</sup>H, <sup>13</sup>C, and <sup>2</sup>H. The NMR samples were prepared by dissolving Securidine A (**1**) in 500 μL methanol-*d*<sub>3</sub> and transferred into a 5 mm disposable tube. Experiments were typically acquired using gradient selected adiabatic versions where applicable. All experiments were acquired using Top Spin 3.5 pl2 at 298 K.

### 3.5. Bioassays

#### 3.5.1. Cytotoxicity

*Cell culturing*—Human melanoma A2058 (ATCC-CRL-1114 TM, Manassas, VA, USA) and human colon adenocarcinoma HT29 (ATCC HTB-38 TM) were grown in Dulbecco's Modified Eagle Medium (DMEM) (Life technologies TM, city, UK) and Roswell Park Memorial Institute (RPMI)–1640 medium

(Biochrom GmbH, Germany) respectively. Both media were supplemented with fetal bovine serum (10%), gentamycin (10 mg/ml), and L-alanyl-L-glutamine (200 mM). Human breast cancer MCF7 (ATCC HTB-22<sup>TM</sup>) cells were grown in Eagle's Minimum Essential Medium (E-MEM) (Biochrom, GmbH, Berlin, Germany) supplemented with fetal bovine serum (10%), gentamycin (10 mg/mL), non-essential amino acid without L-alanyl-L-glutamine, sodium pyruvate (100 mM), and sodium bicarbonate (7.5% *w/v*). The supplements were purchased from Biochem, GmbH, Berlin, Germany. All cells were incubated at 37 °C with 5% CO<sub>2</sub> and 95% air. Cells were sub-cultured with fresh medium every three to four days. The test concentrations (50 µM and 100 µM) were prepared from the stock solution of pure compound (10 mg/mL in 100% DMSO) which is dissolved in supplemented RPMI-1640 medium.

Cell viability was tested against three adherent cancer cell lines, human melanoma A2058, human colon adenocarcinoma HT29, and human breast cancer MCF7 cell lines in vitro, using an MTS [3-(4,5-dimethylthiazol-2-yl)-5-(3-carboxymethoxyphenyl)-2-(4-sulfophenyl)-2H-tetrazolium inner salt] colorimetric method. The growing cells were suspended in 100 µL of supplemented medium seeded at a density of 2000 cells/well in a 96-well microtiter plates (Nunclon<sup>TM</sup> Delta Surface, Thermo Fisher Scientific, Denmark). The cells were incubated at 37 °C for 24 h. After removal of old medium, the cells were treated with 50 µM and 100 µM of Securidine A (1). After 72 h incubation, 10 µL of Cell titer 96<sup>®</sup> Aqueous One Solution Reagent (Promega, Madison, WI, USA) was added to each well and the plates were incubated for 1 h. The absorbance readings at 485 nm was measured using DTX 880 multimode detector (Beckman coulter, CA, USA). Cells with RPMI-1640 medium were used as negative control and cells treated with Triton<sup>®</sup> X-100 (Sigma-Aldrich, Steinheim, Germany) as positive control. Growth inhibition was measured by optical density (OD) and was calculated as: Cell survival (%) = (Average of parallels – positive control)/(negative control – positive control) × 100

### 3.5.2. Antibacterial Assay

*Test strains and culture media*—The antibacterial activity of Securidine A (1) was determined by using a minimum inhibitory concentration (MIC) assay against *Staphylococcus aureus* (ATCC 25923), *Escherichia coli* (ATCC 25922), *Enterococcus faecalis* (ATCC 29212), *Pseudomonas aeruginosa* (ATCC 27853), and *Streptococcus agalactiae* (ATCC 12386). Antibacterial test was performed in sterile Muller Hinton broth (Becton Dickinson, Sparks, MD, USA) and brain heart infusion broth (Becton Dickinson). The bacterial cultures were obtained from the stock (−80 °C) and were grown on blood agar (acquired from the University hospital, UiT, Tromsø, Norway) at 37 °C for 24 h and working bacterial stock culture were maintained at 4 °C. An overnight culture of each strain was prepared and 2 mL of overnight culture was inoculated in 25 mL of growth media and incubated at 37 °C on the shaker at 180 rpm, until the culture reaches the turbidity according to 0.5 McFarland standard (1.0 × 10<sup>8</sup> colony forming unit (CFU)/mL). In this study, bacterial cultures were diluted in 1:100 and then 1:10 in growth media and the final concentration of bacterial cells in the wells were adjusted to 0.5–3.0 × 10<sup>5</sup> (CFU)/mL of *S. aureus*, *E. coli*, *E. faecalis*, and *Streptococcus agalactiae* and 3.0–7.0 × 10<sup>4</sup> CFU/mL of *P. aeruginosa*. Test concentrations (50 µM and 100 µM) were prepared from the stock solution of Securidine A (1) (10 mg/mL in 100% DMSO), and was dissolved in MilliQ water.

From the test concentrations, 50 µL was transferred into a 96-well microtiter plate (Nunclon<sup>TM</sup> Delta Surface, Thermo Fisher Scientific, Denmark). Subsequently, 50 µL of final concentration of bacterial cells were added and incubated at 37 °C for 24 h. After incubation, the activity was measured as absorbance at 600 nm in a plate reader (1420 Victor<sup>3</sup><sup>TM</sup> multilabel counter, PerkinElmer<sup>®</sup>, Singapore) and WorkOut 2.0 software (Dazdaq Ltd, Brighton, UK) was used for plate reading. Bacterial suspension with MilliQ water was used as positive control and growth medium with MilliQ water as negative control. Gentamycin (Amresco, OH, USA) was used as the reference control of this assay. The inhibition was evaluated by the average of parallel OD value. The OD value ≤0.05 considered as active and ≥0.09 was considered inactive.

### 3.5.3. Protein Tyrosine Phosphatase 1B Assay

**Reagents**—(4-(2-hydroxyethyl)-1-piperazineethanesulfonic acid (HEPES; Sigma-Aldrich, Steinheim, Germany), sodium chloride (NaCl; Sigma-Aldrich), dithiothreitol (Sigma-Aldrich), ethylene diamine tetra-acetic acid disodium salt dehydrate (EDTA; Sigma-Aldrich), bovine serum albumin (Sigma Aldrich), human recombinant protein tyrosine phosphatase 1B enzyme (PTP1B; Merck-Calbiochem, Darmstadt, Germany), protein tyrosine phosphatase inhibitor IV (Merck-Calbiochem), 6,8-difluoro-4-methylumbelliferylphosphate (DiFMUP; VWR, Leuven, Belgium).

The test concentration (10  $\mu$ M and 50  $\mu$ M) was obtained from stock solution (10 mg/mL in 100% DMSO) of Securidine A (**1**) and was dissolved in the assay buffer.

PTP1B activity of Securidine A (**1**) was measured in the presence of human recombinant PTP1B enzyme, fluorogenic substrate DiFMUP, and the buffer solution in black polystyrene 96-well microtiter plate (FluoroNunc<sup>TM</sup> MaxiSorp Surface, Capital Scientific, TX, USA). The final volume of the mixture was 100  $\mu$ L in each well. Each well contained 25  $\mu$ L of buffer solution (pH 7.2) (25 mM HEPES, 50 mM NaCl, 2 mM dithiothreitol, 2.5 mM EDTA and 0.01 mg/mL bovine serum albumin), 25  $\mu$ L of Securidine A (**1**), and 50  $\mu$ L of PTP1B enzyme (31.2 ng/mL). Then, the plate was incubated at 37 °C. After 30 min incubation, 25  $\mu$ L of 10  $\mu$ M fluorogenic substrate DiFMUP was added into wells and incubated again at 37 °C for 10 min. The inhibition of enzyme activity was measured as the intensity of fluorescence at 360 nm excitation and 465 nm emission wavelengths by using DTX 880 Multimode detector (Beckman coulter, CA, USA). The assay buffer was used as the positive control and protein tyrosine inhibitor IV (160  $\mu$ M) was used as the negative control. The inhibition of enzyme activity was measured from the fluorescence and calculated with positive and negative control. The inhibition of enzyme activity was expressed in percentage and the activity lower than 30% was considered active. The inhibition of enzyme activity was calculated by (Average of triplicates – negative control)/(positive control – negative control)  $\times$  100.

### 3.5.4. Biofilm Assay

**Test strains**—The test strains *Staphylococcus epidermidis* (RP62A-42-77 ATCC-35984) and *Staphylococcus haemolyticus* (Clinical isolate 8-7A) from the stock were grown on blood agar (acquired from University hospital, UiT, Tromsø) at 37 °C for 24 h and these working bacterial stock were maintained at 4 °C.

The bacterial strain *S. epidermidis* was used to test the biofilm formation on the polystyrene 96-well microtiter plate (Nunclon<sup>TM</sup> Delta Surface, 734-2097, Thermo Fisher Scientific, Denmark). The overnight culture was grown in 5 mL of sterile tryptic soy broth (TSB; Merck, Darmstadt, Germany) in a shaking incubator at 37 °C and diluted in 1:100 in TSB medium with 1% of glucose (Sigma-Aldrich). Securidine A (**1**) from the stock (10 mg/mL) was dissolved in the MilliQ water, to prepare 100  $\mu$ M test concentration. From the test concentration, 50  $\mu$ L was transferred into the wells, subsequently the diluted test strain 50  $\mu$ L was added and incubated at 37 °C for overnight. *S. epidermidis* with sterile MilliQ water was used as positive, *S. haemolyticus* with sterile MilliQ water was used as negative control and medium, with sterile MilliQ water used as blank.

The biofilm formation in the well was determined by using crystal violet (Merck) staining. The bacterial suspension was removed carefully on the cell paper and the plate was gently washed with tap water two or three times. After the biofilm fixation was done at 65 °C for 1 h, the cells were stained with 70  $\mu$ L 0.1% of crystal violet. After 10 min incubation, the crystal violet was removed carefully on the cell paper and the plate was washed with tap water two or three times. The plate was dried at 65 °C for 1 h and 70  $\mu$ L 70% ethanol (VWR) was added into the wells. Thereafter, the microtiter plate was placed on a shaker for 5–10 min. The inhibition of biofilm was assessed by using in the Victor<sup>3</sup><sup>TM</sup> multilabel counter at 600 nm and measuring the optical density (OD). If the inhibition of biofilm rate was 0.25 or lower the OD value was considered active.

#### 4. Conclusions

The new brominated tyrosine derivative Securidine A (**1**) was isolated from the aqueous extract of the marine bryozoan *Securiflustra securifrons*. The structure was determined by interpretation of data from 1D and 2D NMR experiments and mass spectrometry analysis. In this study, Securidine A (**1**) did not show any significant biological activities in the applied bioassays. Further bioactivity profiling is required in order to identify any potential biological activities of the molecule.

**Supplementary Materials:** Supplementary data S1–S6 ( $^1\text{H}$ ,  $^{13}\text{C}$ , HSQC, HMBC, H2BC, COSY and ROESY NMR spectral data of isolated compound) associated with this article can be found online.

**Acknowledgments:** The authors would like to thank Marbank for marine bryozoan collection, identification, and extraction preparation. MabCent is a center at the Arctic University of Tromsø and is supported by the Research council of Norway, Grant No. 174885/130. We also would like to acknowledge the department engineer Marte Albrigtsen for her technical assistance with bioassay experiments. The publication charges for this article have been funded by a grant from the publication fund of UiT The Arctic University of Norway.

**Author Contributions:** K.Ø.H. isolated the compound; K.Ø.H. and J.I. elucidated the structure; P.M. tested the biological activity; K.Ø.H., J.H.A., and E.H. designed the study; P.M., K.Ø.H., and E.H. prepared the manuscript.

**Conflicts of Interest:** The authors declare no conflict of interest.

#### References

1. Hansen, E.; Andersen, H.J. Screening for marine natural products with potential as chemotherapeutics for acute myeloid leukemia. *Curr. Pharm. Biotechnol.* **2016**, *17*, 71–77. [[CrossRef](#)] [[PubMed](#)]
2. Hu, G.P.; Yuan, J.; Sun, L.; She, Z.G.; Wu, J.H.; Lan, X.J.; Zhu, X.; Lin, Y.C.; Chen, S.P. Statistical research on marine natural products based on data obtained between 1985 and 2008. *Mar. Drugs* **2011**, *9*, 514–525. [[CrossRef](#)] [[PubMed](#)]
3. Sinko, J.; Rajchard, J.; Balounova, Z.; Fikotova, L. Biologically active substances from water invertebrates: A review. *Vet. Med. Czech* **2012**, *57*, 177–184.
4. Avila, C.; Taboada, S.; Núñez-pons, L. Antarctic marine chemical ecology: What is next? *Mar. Ecol.* **2008**, *29*, 1–71. [[CrossRef](#)]
5. Schumacher, M.; Kelkel, M.; Dicato, M.; Diederich, M. Gold from the sea: Marine compounds as inhibitors of the hallmarks of cancer. *Biotechnol. Adv.* **2011**, *29*, 531–547. [[CrossRef](#)] [[PubMed](#)]
6. Christophersen, C. Secondary metabolites from marine bryozoans. A review. *Acta. Chem. Scand.* **1985**, *39*, 517–529. [[CrossRef](#)]
7. Blackman, A.J.; Davies, N.W.; Ralph, C.E. Volatile and odorous compounds from the bryozoan *Biflustra perfragilis*. *Biochem. Syst. Ecol.* **1992**, *20*, 339–342. [[CrossRef](#)]
8. Bock, P.E.; Gordon, D.P. Phylum bryozoa ehrenberg, 1831. In *Animal Biodiversity: An Outline of Higher-Level Classification and Survey of Taxonomic Richness (Addenda 2013)* Zootaxa; Zhang, Z.Q., Ed.; Magnolia Press: Auckland, New Zealand, 2013; Volume 3703, pp. 67–74.
9. Sharp, J.H.; Winson, M.K.; Porter, J.S. Bryozoan metabolites: An ecological perspective. *Nat. Prod. Rep.* **2007**, *24*, 659–673. [[CrossRef](#)] [[PubMed](#)]
10. Kiuru, P.; D’Auria, M.V.; Muller, C.D.; Tammela, P.; Vuorela, H.; Yli-Kauhaluoma, J. Exploring marine resources for bioactive compounds. *Planta Med.* **2014**, *80*, 1234–1246. [[CrossRef](#)] [[PubMed](#)]
11. Wang, A.T.; Prinsep, M.R.; Martinus, R.D. Pterocellin A isolated from marine bryozoan *Pterocella vesiculosa* is cytotoxic to human HeLa cells via mitochondrial apoptotic processes. *SpringerPlus* **2016**, *5*, 1–11. [[CrossRef](#)] [[PubMed](#)]
12. Wright, J.L. A new antibiotic from the marine bryozoan *Flustra foliacea*. *J. Nat. Prod.* **1984**, *47*, 893–895. [[CrossRef](#)] [[PubMed](#)]
13. Tadesse, M.; Tabudravu, J.N.; Jaspars, M.; Strom, M.B.; Hansen, E.; Andersen, J.H.; Kristiansen, P.E.; Haug, T. The antibacterial ent-eusynstyelamide B and eusynstyelamides D, E, and F from the Arctic bryozoan *Tegella cf. spitzbergensis*. *J. Nat. Prod.* **2011**, *74*, 837–841. [[CrossRef](#)] [[PubMed](#)]
14. Sjöblom, T.; Bohlin, L.; Christophersen, C. Studies of Swedish marine organisms. II. Muscle-relaxant alkaloids from the marine bryozoan *Flustra foliacea*. *Acta. Pharm. Suec.* **1983**, *20*, 415–418. [[PubMed](#)]

15. Leal, M.C.; Sheridan, C.; Osinga, R.; Dionisio, G.; Rocha, R.J.M.; Silva, B.; Rosa, R.; Calado, R. Marine microorganism-invertebrate assemblages: Perspectives to solve the “Supply Problem” in the initial steps of drug discovery. *Mar. Drugs* **2014**, *12*, 3929–3952. [[CrossRef](#)] [[PubMed](#)]
16. Anthoni, U.; Nielsen, P.H.; Pereira, M.; Christophersen, C. Bryozoan secondary metabolites: A chemotaxonomical challenge. *Comp. Biochem. Physiol.* **1990**, *96B*, 431–437. [[CrossRef](#)]
17. Blunt, J.W.; Copp, B.R.; Keyzers, R.A.; Munro, M.H.G.; Prinsep, M.R. Marine natural products. *Nat. Prod. Rep.* **2015**, *32*, 116–211. [[CrossRef](#)] [[PubMed](#)]
18. Sonnewald, M.; Türkay, M. The megaepifauna of the Dogger Bank (North Sea): Species composition and faunal characteristics 1991–2008. *Helgol. Mar. Res.* **2012**, *66*, 63–75. [[CrossRef](#)]
19. Ryland, J.S.; Hayward, P.J. *Marine Flora and Fauna of the Northern United States Erect Bryozoa*; National Marine Fisheries Service: Marmora, NJ, USA, 1991; pp. 1–47.
20. Rahbaek, L.; Anthoni, U.; Christophersen, G.; Nielsen, P.H.; Petersen, B.O. Marine alkaloids. 18. Securamines and securines, halogenated indole-imidazole alkaloids from the marine bryozoan *Securiflustra securifrons*. *J. Org. Chem.* **1996**, *61*, 887–889. [[CrossRef](#)]
21. Rahbæk, L.; Christophersen, C. Marine alkaloids. 19. Three new alkaloids, securamines E-G, from the marine bryozoan *Securiflustra securifrons*. *J. Nat. Prod.* **1997**, *60*, 175–177. [[CrossRef](#)]
22. Chevolut, L.; Chevolut, A.M.; Gajhede, M.; Larsen, C.; Anthoni, U.; Christophersen, C. Marine alkaloids. 10. Chartelline A: A pentahaloalkaloid from the marine bryozoan *Chartella papyracea*. *J. Am. Chem. Soc.* **1985**, *107*, 4542–4543. [[CrossRef](#)]
23. Anthoni, U.; Bock, K.; Chevolut, L.; Larsen, C.; Nielsen, P.H.; Christophersen, C. Chartellamide A and B, halogenated  $\beta$ -lactam indole-imidazole alkaloids from the marine bryozoan *Chartella papyracea*. *J. Org. Chem.* **1987**, *52*, 5638–5639. [[CrossRef](#)]
24. Carle, J.S.; Christophersen, C. Bromo-substituted physostigmine alkaloids from a marine bryozoan *Flustra foliacea*. *J. Am. Chem. Soc.* **1979**, *101*, 4012–4013. [[CrossRef](#)]
25. Carle, J.S.; Christophersen, C. Marine alkaloids. 2. Bromo alkaloids from a marine bryozoan *Flustra foliacea*. Isolation and structure elucidation. *J. Org. Chem.* **1980**, *45*, 1586–1589. [[CrossRef](#)]
26. Carle, J.S.; Christophersen, C. Marine alkaloids. 3. Bromo-substituted alkaloids from the marine bryozoan *Flustra foliacea*, flustramine C and flustraminol A and B. *J. Org. Chem.* **1981**, *46*, 3440–3443. [[CrossRef](#)]
27. Holst, P.; Anthoni, U.; Christophersen, C.; Nielsen, P. Marine alkaloids, 15. 2 alkaloids, flustramine-E and debromoflustramine-B, from the marine bryozoan *Flustra foliacea*. *J. Nat. Prod.* **1994**, *57*, 997–1000. [[CrossRef](#)] [[PubMed](#)]
28. Peters, L.; König, G.M.; Wright, A.D.; Terlau, H. Four new bromotryptamine derivatives from the marine bryozoan *Flustra foliacea*. *J. Nat. Prod.* **2002**, *65*, 1633–1637. [[CrossRef](#)] [[PubMed](#)]
29. Wulff, P.; Carlé, J.S.; Christophersen, C. Marine alkaloids—6. The first naturally occurring bromo-substituted quinoline from *Flustra foliacea*. *Comp. Biochem. Physiol. Part B: Biochem. Mol. Biol.* **1982**, *71*, 525–526. [[CrossRef](#)]
30. Wulff, P.; Carl, J.S.; Christophersen, C. Marine alkaloids 5. Flustramide a and 6-bromo-nb-methyl-nb-formyltryptamine from the marine bryozoan *Flustra foliacea*. *Comp. Biochem. Physiol.* **1982**, *71B*, 523–524.
31. Wulff, P.; Carlé, J.S.; Christophersen, C. Marine alkaloids. Part 4. A formamide, flustrabromine, from the marine bryozoan *Flustra foliacea*. *J. Chem. Soc. JCS Perkin I* **1981**, 2895–2898. [[CrossRef](#)]
32. Rochfort, S.J.; Moore, S.; Craft, C.; Martin, N.H.; Van Wagoner, R.M.; Wright, J.L.C. Further studies on the chemistry of the flustra alkaloids from the bryozoan *Flustra foliacea*. *J. Nat. Prod.* **2009**, *72*, 1773–1781. [[CrossRef](#)] [[PubMed](#)]
33. Svenson, J. MabCent: Arctic marine bioprospecting in Norway. *Fundam. Perspect. Nat. Prod. Res.* **2013**, *12*, 567–578. [[CrossRef](#)] [[PubMed](#)]
34. Tadesse, M.; Strøm, M.B.; Svenson, J.; Jaspars, M.; Milne, B.F.; Tørfoss, V.; Andersen, J.H.; Hansen, E.; Stensvåg, K.; Haug, T. Synoxazolidinones A and B: Novel bioactive alkaloids from the ascidian *Synoicum pulmonaria*. *Org. Lett.* **2010**, *12*, 4752–4755. [[CrossRef](#)] [[PubMed](#)]
35. Tadesse, M.; Svenson, J.; Sepčić, K.; Trembleau, L.; Engqvist, M.; Andersen, J.H. Isolation and synthesis of pulmonarin A and B, acetylcholinesterase inhibitors from the colonial ascidian *Synoicum pulmonaria*. *J. Nat. Prod.* **2014**, *77*, 364–369. [[CrossRef](#)] [[PubMed](#)]

36. Macherla, V.; Liu, J.; Sunga, M.; White, D.; Grodberg, J.; Teisan, S.; Lam, K.; Potts, B.; Macherla, V. Lipoxazolidinones A, B, and C: Antibacterial 4-oxazolidinones from a marine actinomycete isolated from a Guam marine sediment. *J. Nat. Prod.* **2007**, *70*, 1454–1457. [[CrossRef](#)] [[PubMed](#)]
37. Paulsen, V.S.; Blencke, H.-M.; Benincasa, M.; Haug, T.; Eksteen, J.J.; Styrvold, O.B.; Scocchi, M.; Stensvag, K. Structure-activity relationships of the antimicrobial peptide Arasin 1 - and mode of action studies of the N-terminal, proline-rich region. *PLoS ONE* **2013**, *8*, 1–11. [[CrossRef](#)] [[PubMed](#)]
38. Igumnova, E.M.; Mishchenko, E.; Haug, T.; Blencke, H.-M.; Sollid, J.U.E.; Fredheim, E.G.A.; Lauksund, S.; Stensvåg, K.; Strøm, M.B. Synthesis and antimicrobial activity of small cationic amphipathic aminobenzamide marine natural product mimics and evaluation of relevance against clinical isolates including ESBL–CARBA producing multi-resistant bacteria. *Bioorg. Med. Chem.* **2016**, *24*, 5884–5894. [[CrossRef](#)] [[PubMed](#)]
39. Solstad, R.; Li, C.; Isaksson, J.; Johansen, J.; Svenson, J.; Stensvag, K.; Haug, T.; Solstad, R. Novel antimicrobial peptides EeCentrocins 1, 2 and EeStrongylocin 2 from the edible sea urchin *Echinus esculentus* have 6-Br-Trp post-translational modifications: e0151820. *PLoS ONE* **2016**, *11*, 1–25. [[CrossRef](#)] [[PubMed](#)]
40. Strøm, M.; Haug, B.; Skar, M.; Stensen, W.; Stiberg, T.; Svendsen, J.; Stroem, M. The pharmacophore of short cationic antibacterial peptides. *J. Med. Chem.* **2003**, *46*, 1567–1570. [[CrossRef](#)] [[PubMed](#)]
41. Wang, L.J.; Jiang, B.; Wu, N.; Wang, S.Y.; Shi, D.Y. Natural and semisynthetic protein tyrosine phosphatase 1B (PTP1B) inhibitors as anti-diabetic agents. *RSC Adv.* **2015**, *5*, 48822–48834. [[CrossRef](#)]
42. Trepos, R.; Cervin, G.; Hellio, C.; Pavia, H.; Stensen, W.; Stensvåg, K.; Svendsen, J.S.; Haug, T.; Svenson, J. Antifouling compounds from the sub-arctic ascidian *Synoicum pulmonaria*: Synoxazolidinones A and C, pulmonarins A and B, and synthetic analogues. *J. Nat. Prod.* **2014**, *77*, 2105–2113. [[CrossRef](#)] [[PubMed](#)]

**Sample Availability:** Samples of the compounds are available from the authors.



© 2017 by the authors. Licensee MDPI, Basel, Switzerland. This article is an open access article distributed under the terms and conditions of the Creative Commons Attribution (CC BY) license (<http://creativecommons.org/licenses/by/4.0/>).

**Title:** A Novel Brominated Alkaloid Securidine A, Isolated from the Marine Bryozoan *Securiflustra securifrons*

**Supplementary materials:** 1D NOE, 13C-NMR, HMBC, ME-HSQC, H2BC, COSY and ROESY correlations of compound Securidine A (**1**)

**Authors:** Priyanka Siranjeevi <sup>1\*a</sup>, Kine Ø. Hansen <sup>1\*a</sup>, Johan Isaksson <sup>2</sup>, Jeanette H. Andersen <sup>1</sup> and Espen Hansen <sup>1</sup>.

<sup>1</sup> MARBIO, UiT – The Arctic University of Norway, Brevika, N-9037, Tromsø, Norway; [raja.p.siranjeevi@uit.no](mailto:raja.p.siranjeevi@uit.no) (P.S); [kine.o.hanssen@uit.no](mailto:kine.o.hanssen@uit.no) (K.Ø.H); [jeanette.h.andersen@uit.no](mailto:jeanette.h.andersen@uit.no) (J.H.A); [espen.hansen@uit.no](mailto:espen.hansen@uit.no) (E.H)

<sup>2</sup> Department of Chemistry, UiT – The Arctic University of Norway, Brevika, N-9037, Tromsø, Norway; [johan.isaksson@uit.no](mailto:johan.isaksson@uit.no) (J.I)

\* Correspondence: [raja.p.siranjeevi@uit.no](mailto:raja.p.siranjeevi@uit.no); Tel.: +47-77649268; [kine.o.hanssen@uit.no](mailto:kine.o.hanssen@uit.no); Tel.: +47-77649272

<sup>a</sup> These authors contributed equally to this work.

**Figure S1.** 1D NOE spectrum of securidine A (**1**)

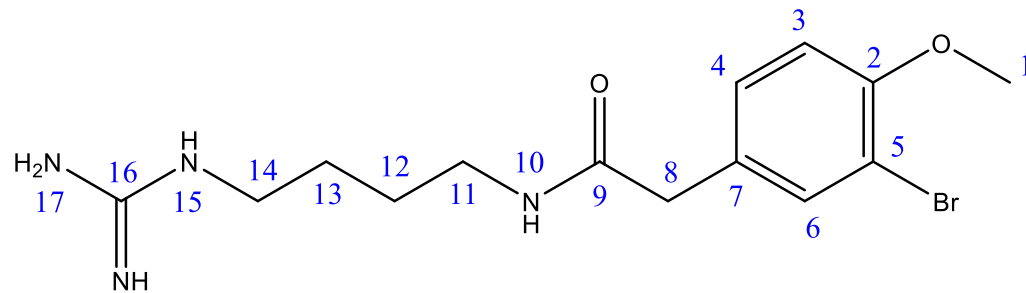
**Figure S2.** 13C-NMR spectrum of **1**.

**Figure S3.** Combined HSQC and HMBC spectra of **1**.

**Figure S4.** H2BC spectra of **1**

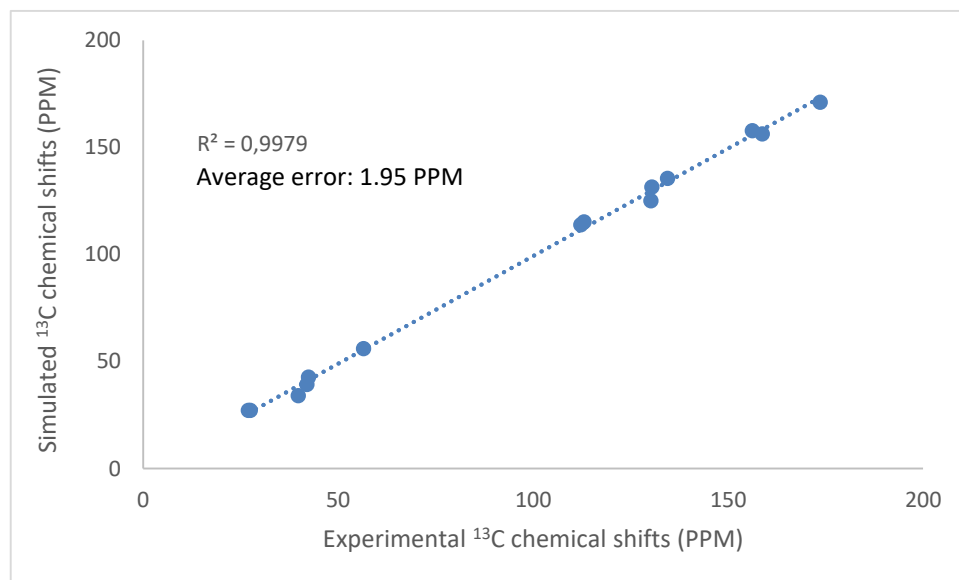
**Figure S5.** COSY Spectrum of **1**.

**Figure S6.** ROESY spectrum of **1**.



Chemical Formula:  $C_{14}H_{21}BrN_4O_2$

Exact Mass: 356,08

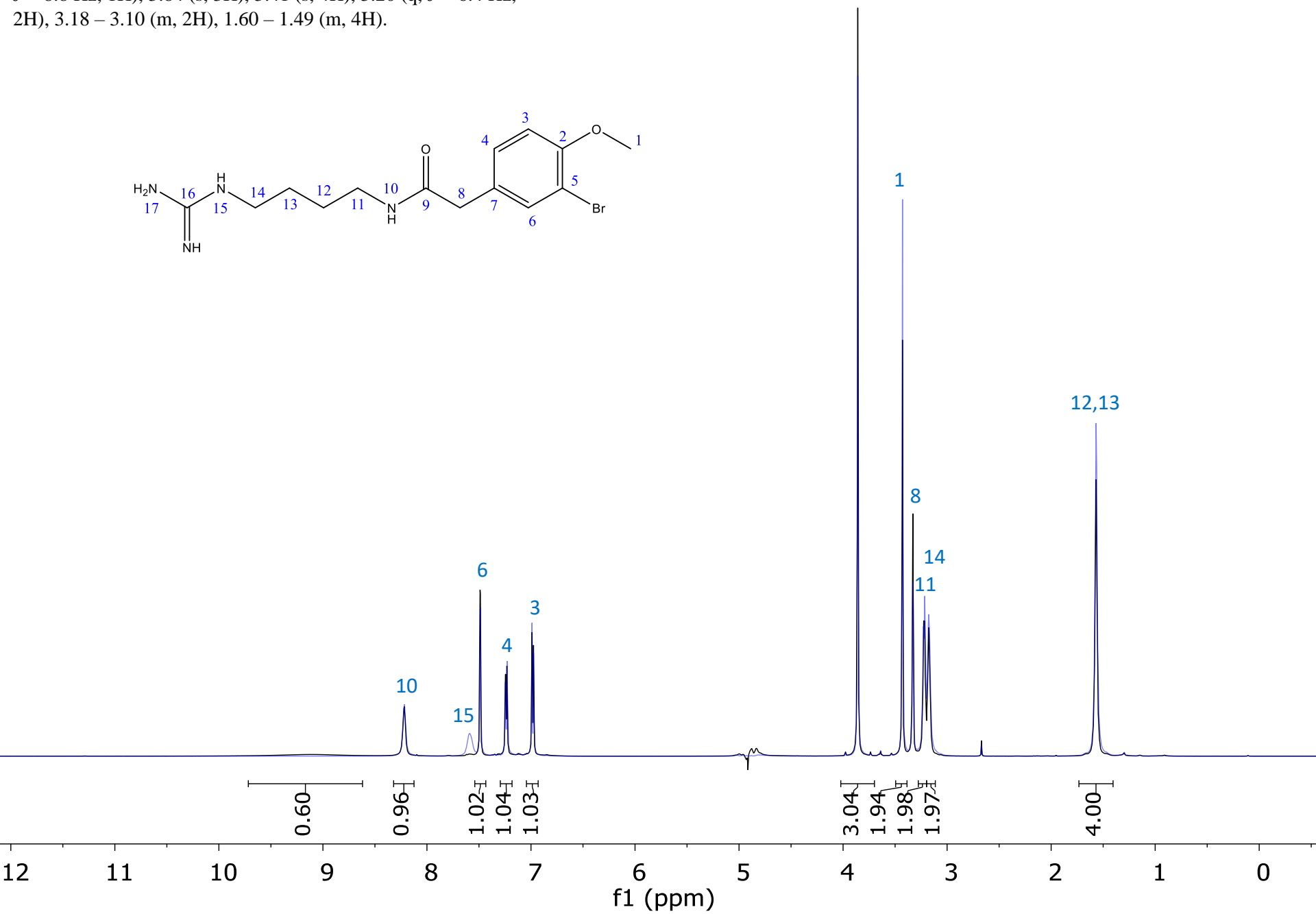
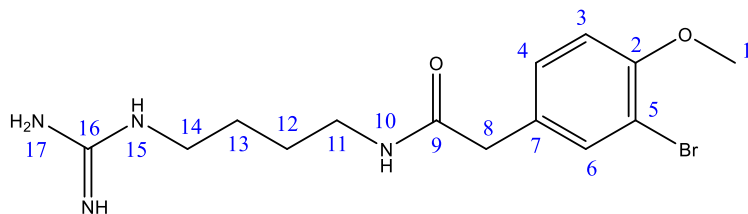




<sup>1</sup>H NMR (600 MHz, Methanol-*d*<sub>4</sub>) δ 8.20 (s, 1H), 7.57 (s, 1H), 7.47 (d, *J* = 2.3 Hz, 1H), 7.22 (dd, *J* = 8.6, 2.3 Hz, 1H), 6.96 (d, *J* = 8.8 Hz, 1H), 3.84 (s, 3H), 3.41 (s, 4H), 3.20 (q, *J* = 6.4 Hz, 2H), 3.18 – 3.10 (m, 2H), 1.60 – 1.49 (m, 4H).

# 1D NOE + ES

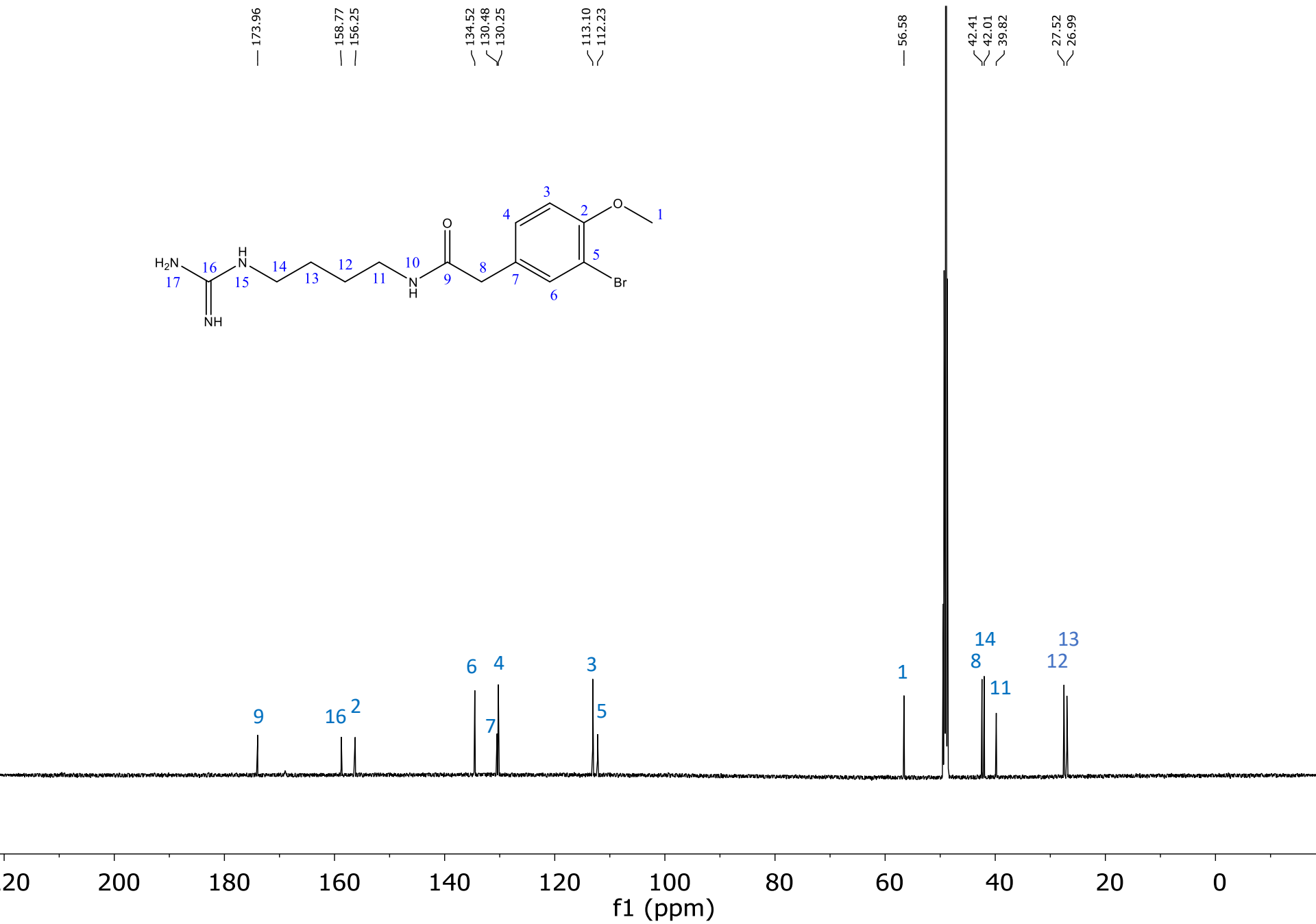
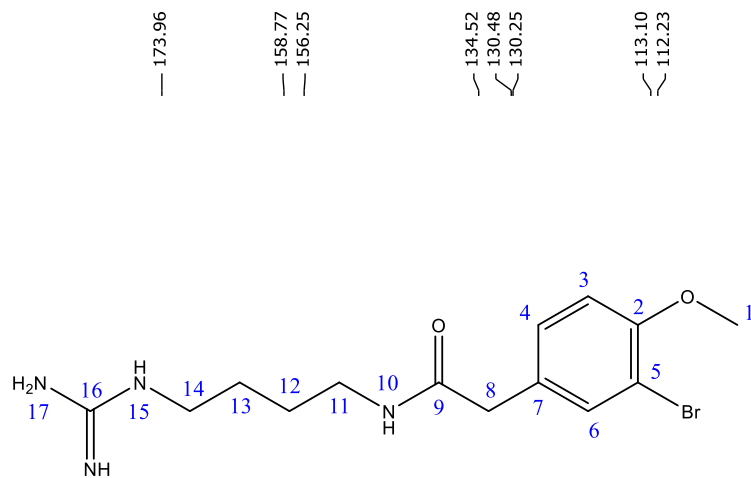
methanol-*d*<sub>3</sub>, 298 K

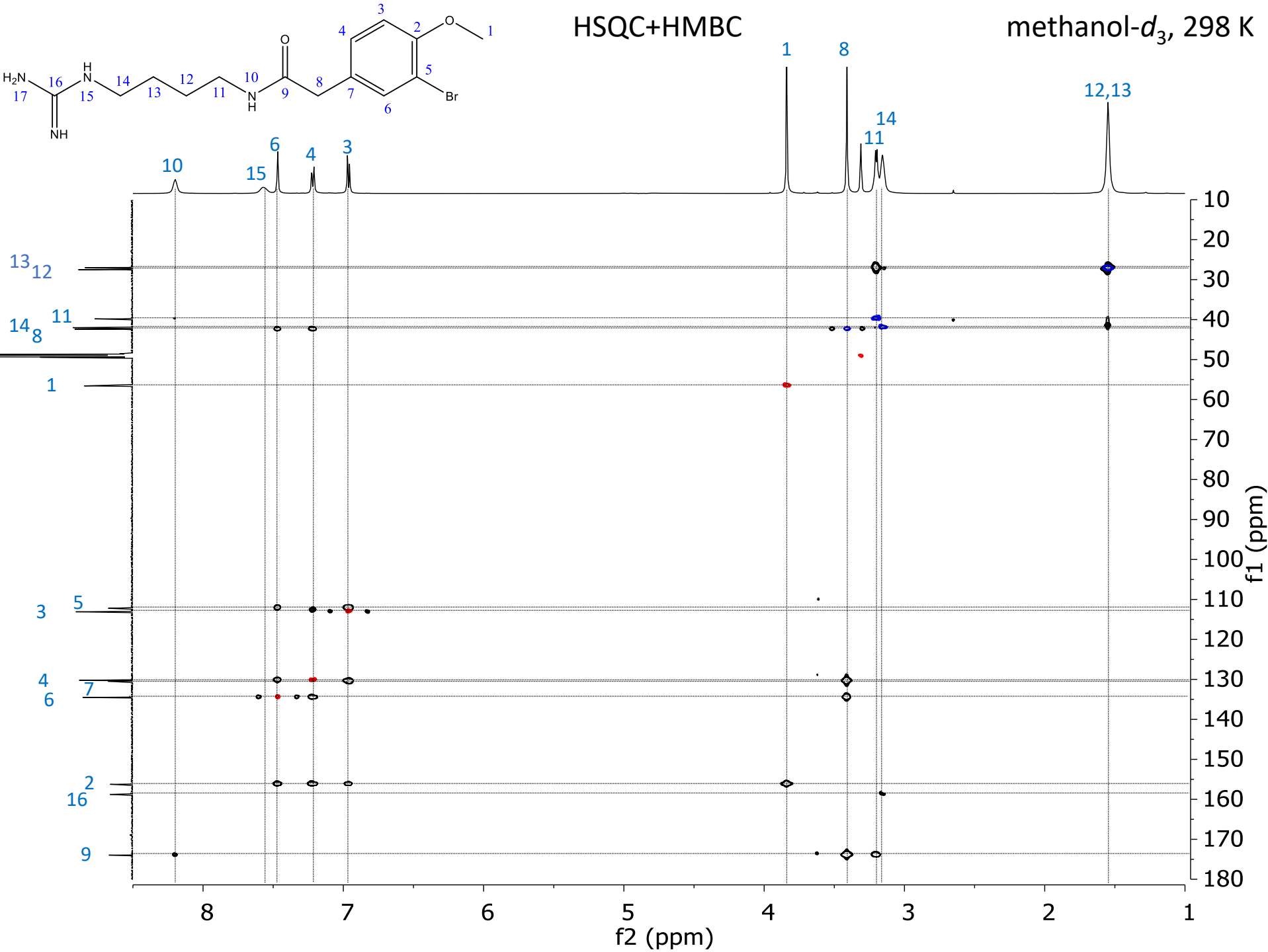


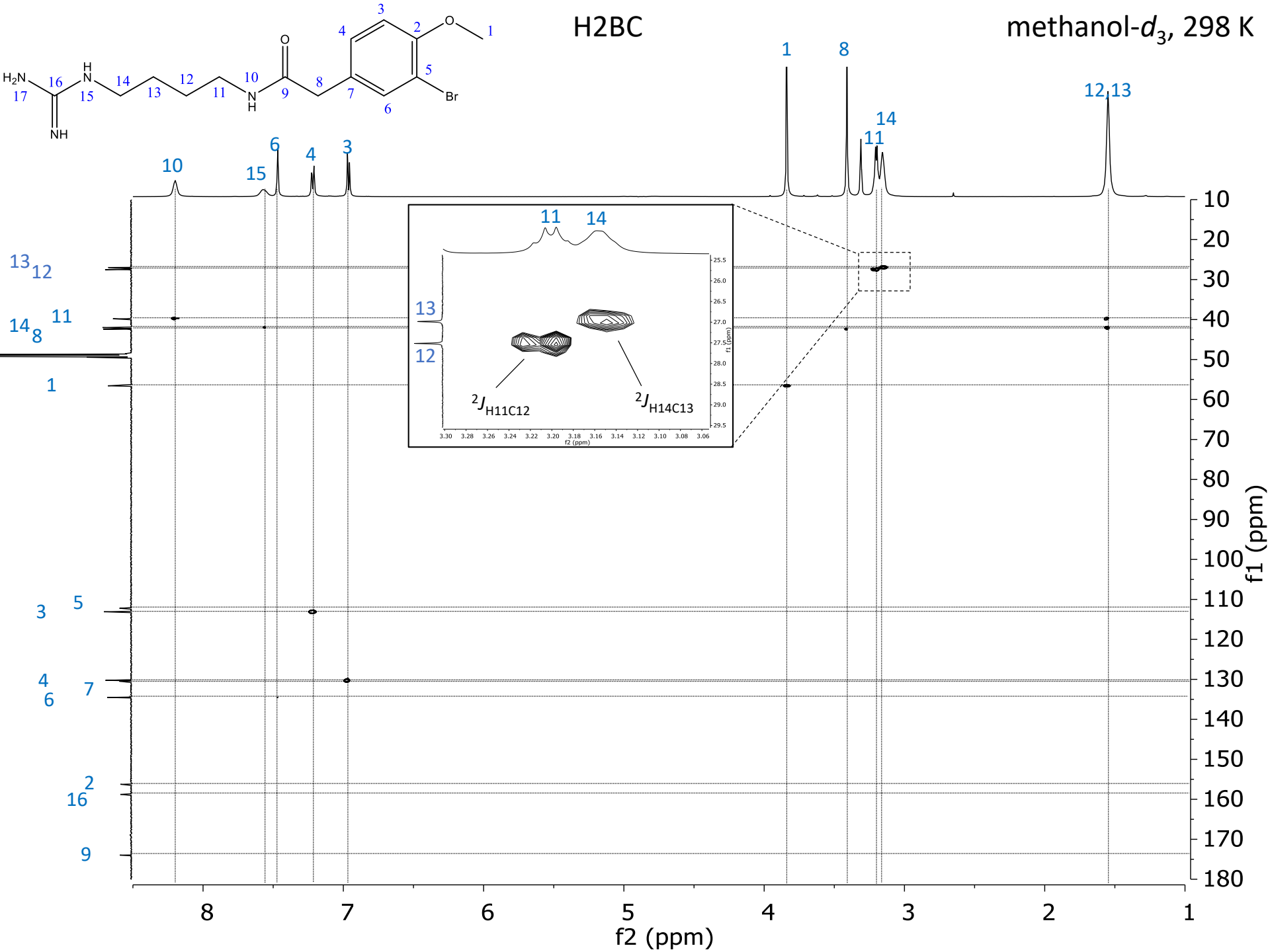
$^{13}\text{C}$  NMR (151 MHz, MeOD)  $\delta$  173.96, 158.77, 156.25, 134.52, 130.48, 130.25, 130.25, 113.10, 112.23, 56.58, 42.41, 42.01, 39.82, 27.52, 26.99.

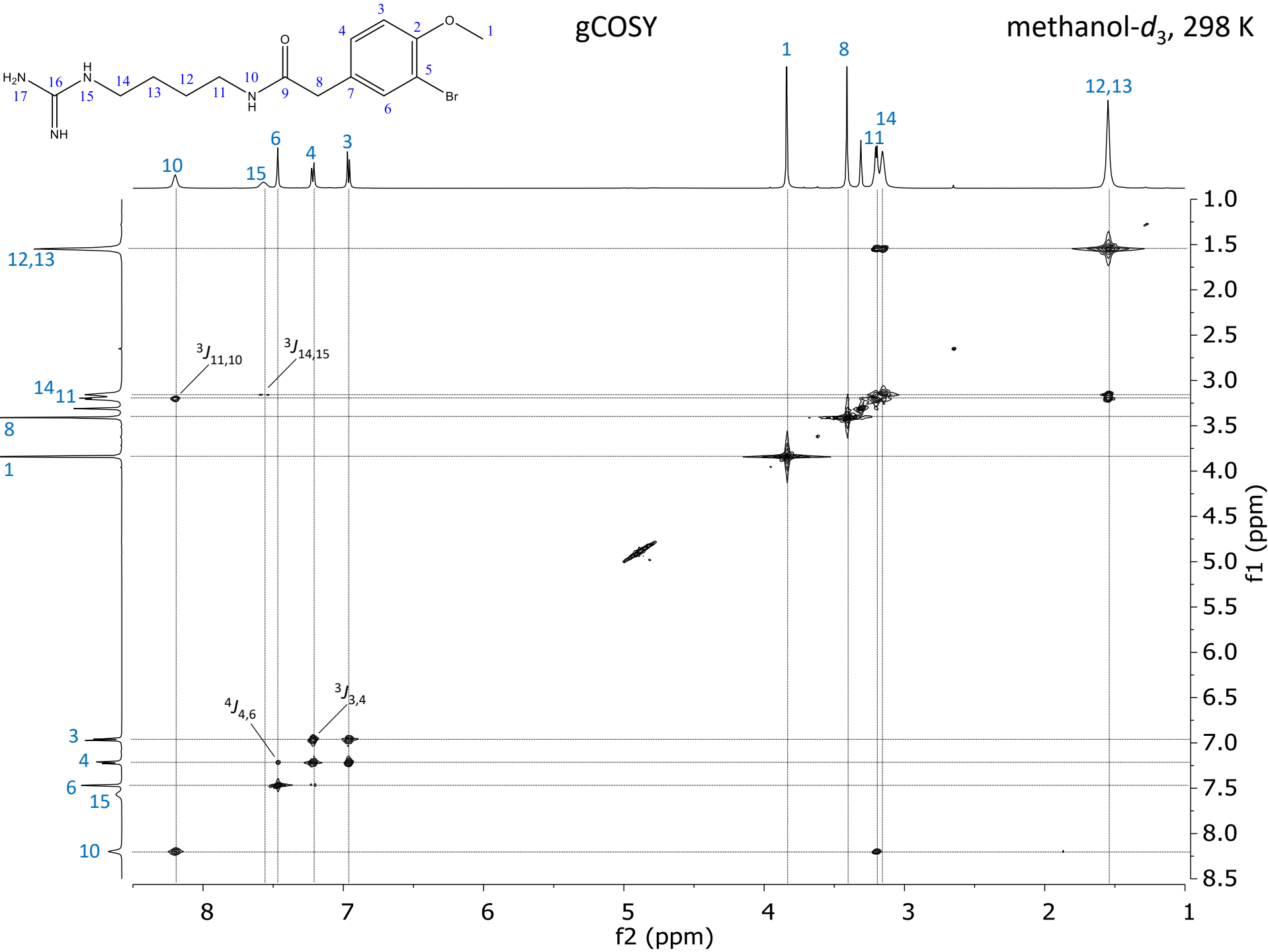
CARBON

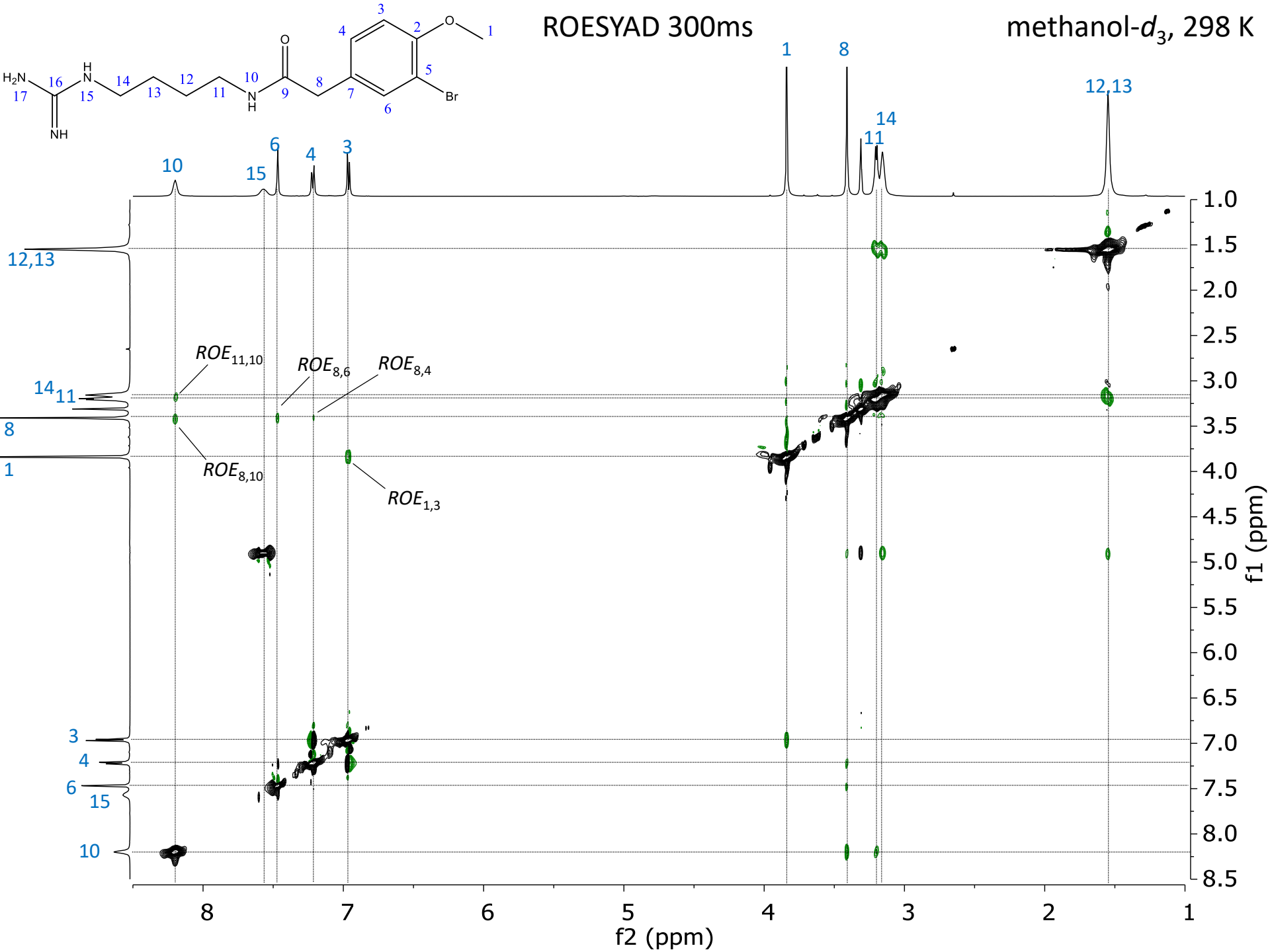
methanol- $d_3$ , 298 K



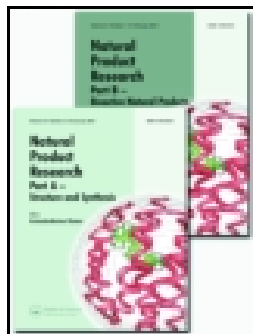








## Paper II



# Natural Product Research

Formerly Natural Product Letters

ISSN: 1478-6419 (Print) 1478-6427 (Online) Journal homepage: <https://www.tandfonline.com/loi/gnpl20>


## Dendrobeaniamine A, a new alkaloid from the Arctic marine bryozoan *Dendrobeatia murrayana*

Priyanka Michael, Espen Hansen, Johan Isaksson, Jeanette H. Andersen & Kine Ø. Hansen


To cite this article: Priyanka Michael, Espen Hansen, Johan Isaksson, Jeanette H. Andersen & Kine Ø. Hansen (2019): Dendrobeaniamine A, a new alkaloid from the Arctic marine bryozoan *Dendrobeatia murrayana*, Natural Product Research, DOI: [10.1080/14786419.2019.1574788](https://doi.org/10.1080/14786419.2019.1574788)

To link to this article: <https://doi.org/10.1080/14786419.2019.1574788>

 View supplementary material 

 Published online: 20 Feb 2019.

 Submit your article to this journal 

 Article views: 53

 View Crossmark data 





## Dendrobeaniamine A, a new alkaloid from the Arctic marine bryozoan *Dendrobeania murrayana*

Priyanka Michael<sup>a</sup>, Espen Hansen<sup>a</sup>, Johan Isaksson<sup>b</sup>, Jeanette H. Andersen<sup>a</sup> and Kine Ø. Hansen<sup>a</sup>

<sup>a</sup>Marbio UiT–The Arctic University of Norway, Breivika, Tromsø, Norway; <sup>b</sup>Department of Chemistry, UiT–The Arctic University of Norway, Breivika, Tromsø, Norway

### ABSTRACT

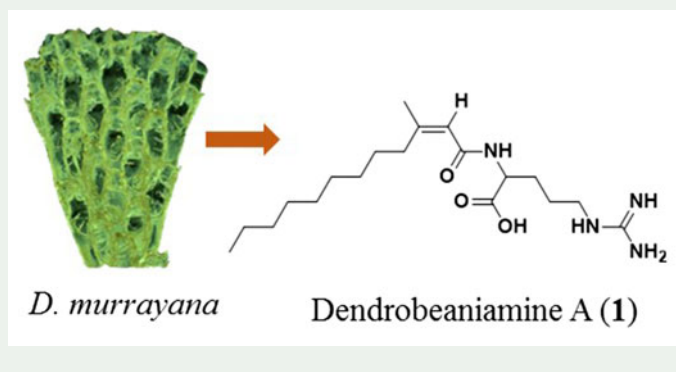
The new guanidine alkaloid Dendrobeaniamine A (**1**) was isolated from the organic extract of the Arctic marine bryozoan *Dendrobeania murrayana*. The chemical structure of **1** was elucidated by spectroscopic experiments, including 1D and 2D NMR and HRESIMS analysis. Compound **1** is a lipoamino acid, consisting of a C<sub>12</sub> fatty acid anchored to the amino acid arginine. The bioactivity of **1** was evaluated using cellular and biochemical assays, but the compound did not show cytotoxic, antimicrobial, anti-inflammatory or antioxidant activities

### ARTICLE HISTORY

Received 7 December 2018  
Accepted 21 January 2019

### KEYWORDS


Arctic invertebrates; bryozoans; *Dendrobeania murrayana*; bioprospecting; marine secondary metabolites



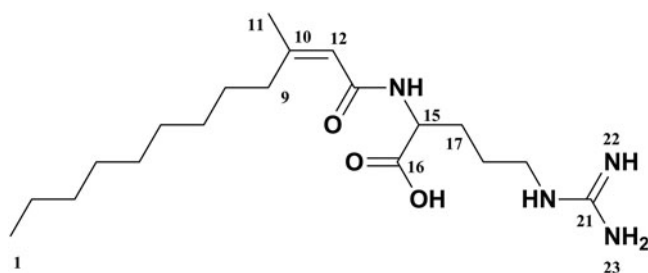
## 1. Introduction

Bryozoans are filter feeding, sessile invertebrates from which structurally diverse bioactive secondary metabolites have been isolated (Ryland 2005; Maltseva et al. 2017; Tian et al. 2018). Despite this, the number of investigations into the natural product chemistry of marine bryozoans is still limited compared to other marine invertebrate phyla. To date, only around 220 secondary metabolites have been isolated from 38 species of marine bryozoans (Blunt et al. 2018). These natural products include the flustramines (Peters et al. 2002), the eusynstyelamides (Tadesse et al. 2011), the bryostatins (Kollár et al. 2014) and the securamines (Hansen et al. 2017).

CONTACT Kine Ø. Hansen  [Kine.o.hanssen@uit.no](mailto:Kine.o.hanssen@uit.no)

 Supplemental data for this article can be accessed at <https://doi.org/10.1080/14786419.2019.1574788>.

© 2019 Informa UK Limited, trading as Taylor & Francis Group



**Figure 1.** The chemical structure of dendrobeaniamine A (1).

As a part of our ongoing search for new secondary metabolites from Arctic invertebrates (Svenson 2013; Michael et al. 2017; Hansen et al. 2018), we are reporting a new secondary metabolite from the Arctic marine bryozoan *Dendrobeania murrayana*, from which the tetracyclic terpenoid murrayanolide have been previously isolated (Yu and Wright 1995). A detailed chemical analysis of the organic extract of *D. murrayana* using UHPLC-HRESIMS revealed the presence of an abundant compound not present in other bryozoan extracts analyzed by our research group. The compound was isolated and its structure elucidated using 1D and 2D NMR and HRESIMS analysis. Potential biological activities of the isolated compound was evaluated using cellular and biochemical assays.

## 2. Results and discussion

### 2.1. Extraction, dereplication and isolation of 1

Specimens of *Dendrobeania murrayana* (550 g wet weight) were collected in the subtidal region of Vesterålsfjorden in Northern Norway and prepared into an organic extract (1.59 g). An aliquot of the organic extract was analyzed by UHPLC-HRESIMS. Comparison of base peak intensity (BPI) chromatograms of the organic extract from *D. murrayana* with other related bryozoans revealed the presence of a unique and prominent peak at  $R_t$  5.7 min with an  $m/z$  of 369.2861 and a calculated elemental composition of  $C_{19}H_{36}N_4O_3$ . The elemental composition gave no hits when searched for in relevant databases (Dictionary of Marine Natural Products and ChemSpider). Based on the prominence of this peak (Figure S1) and its assumed novelty based on the database searches, we decided to isolate the compound and determine its structure.

We isolated the compound from the organic extract using mass guided semi-preparative HPLC fractionation. In order to obtain sufficient purity of the compound, it was purified in two steps; first by applying a  $C_{18}$  column followed by a second step using a fluorophenyl column, both with gradients of water and acetonitrile as mobile phases. The isolation gave 2.5 mg of pure compound **1**.

### 2.2. Structure elucidation of 1

Compound **1** was obtained as a golden yellow wax. The protonated compound had a  $m/z$  of 369.2861, and the elemental composition was  $C_{19}H_{36}N_4O_3$ . The IR spectrum of compound **1** had characteristic signals at 3279, 2936, 2363, 1726, 1626, 1544  $cm^{-1}$ ,

indicating the presence of amine, alkane, alcohol, carbonyl, alkene and imine groups, respectively. The UV  $\lambda_{\max}$  of compound **1** was 223 nm. Through a set of 1D ( $^1\text{H}$ ,  $^{13}\text{C}$ ) and 2D ( $^1\text{H}$ ,  $^{13}\text{C}$ ,  $^{15}\text{N}$ ) (HSQC, HMBC, COSY, NOESY, TOCSY, H2BC,  $^{15}\text{N}$ -HSQC and  $^{15}\text{N}$ -HMBC) NMR experiments, the structure of **1** could be determined (Figure 1, Table S1, Figures S2 and S4–S16).

Initially, only 17 out of the 19 carbons could be identified in the 1D carbon spectrum, the missing carbons were later to be assigned C-15 ( $\delta_{\text{C}}$  55.0) and C-16 ( $\delta_{\text{C}}$  169.6). C-15 was absent in HSQC, but could be identified in a (145 Hz) HMQC. Very weak peaks could eventually be confirmed in an optimized 1D carbon and HMBC. A fine splitting could be observed for carbon peaks belonging to C-10 ( $\delta_{\text{C}}$  155.9), C-12 ( $\delta_{\text{C}}$  119.8), C-13 ( $\delta_{\text{C}}$  168.7) and C-17 ( $\delta_{\text{C}}$  31.2). This indicates that there is a dynamic process, presumably C-15/C-16 rotamers. Comparison to the edited HSQC concluded the carbons to be in total 2  $\text{CH}_3$ , 11  $\text{CH}_2$ , 2  $\text{CH}$  and 4 quaternary carbons. Of these, two had chemical shifts characteristic for carbonyls. The COSY and TOCSY data revealed one spin system consisting of H-14 ( $\delta_{\text{H}}$  7.40), H-15 ( $\delta_{\text{H}}$  4.32), H-17a ( $\delta_{\text{H}}$  1.87), H-17b ( $\delta_{\text{H}}$  1.72), H<sub>2</sub>-18 ( $\delta_{\text{H}}$  1.63) and H<sub>2</sub>-19 ( $\delta_{\text{H}}$  3.21), H-20 ( $\delta_{\text{H}}$  7.55), and a second spin system consisting of an aliphatic chain H<sub>3</sub>-1 ( $\delta_{\text{H}}$  0.89) to H<sub>2</sub>-9 ( $\delta_{\text{H}}$  2.60). Arrangements of the aliphatic chain with respect to the other spin system and the connecting moiety were determined by HMBC, H2BC and COSY correlations (Figure S6–S8). The C-11 ( $\delta_{\text{C}}$  24.8) methyl was attached to the quaternary C-10 ( $\delta_{\text{C}}$  155.9), based on HMBC correlations between H<sub>3</sub>-11 and C-9 ( $\delta_{\text{C}}$  33.9), C-10 and C-12 ( $\delta_{\text{C}}$  119.8) as well as between C-11 and H<sub>2</sub>-9 and H-12. The aliphatic chain was thus connected to C-10. C-13 ( $\delta_{\text{C}}$  168.7) was identified as a carbonyl next to the aromatic C-12, again based on the HMBC pattern, including correlations from HN-14 ( $\delta_{\text{H}}$  7.40) and H-12 ( $\delta_{\text{H}}$  5.74).

The other spin system presented some difficulty because of the putative C-15/C-16 rotamers, resulting in the absence of long range through bonds correlations involving these carbons. The spin system itself was identified as the observable part of an arginine, and the side chain could be traced from the NH (HN-14) to the alpha- (C-15), beta- (C-17), gamma- (C-18) and delta carbon (C-19) and the epsilon NH (HN-20). The only experimental observation connecting it to the rest of the molecule was the  $^3J_{\text{C}13\text{H}14}$  (Figure S6), supported by a NOE from H-14 to H-12 (Figure S10). In the H2BC spectrum, a coupling between H-20 ( $\delta_{\text{H}}$  7.55) and C-19 ( $\delta_{\text{C}}$  42.2) conformed the attachment of an NH to C-19. Furthermore, HMBC correlations between H<sub>2</sub>-19 ( $\delta_{\text{H}}$  3.21) and C-21 ( $\delta_{\text{C}}$  158.7) linked the quaternary C-21 carbon atom to N-20 ( $\delta_{\text{N}}$  84.1). This placed the remaining  $\text{N}_2\text{H}_3$  atoms to C-21, forming a guanidine group. In order to strengthen that the arginine spin system is actually connected to the rest of the molecule via the N-terminal side and not via the C-terminal side, the nitrogen chemical shifts were extracted from a  $^{15}\text{N}$ -HSQC (Figure S13);  $\delta_{\text{N}20}$  84.1 and  $\delta_{\text{N}14}$  127.7 PPM. The nitrogen shifts were consistent with **1**, but not with other potential structures (Figure S15 and S16). A weak  $^{15}\text{N}$ -HMBC between N-20 ( $\delta_{\text{N}}$  84.1) and H<sub>2</sub>-18 ( $\delta_{\text{H}}$  1.63) could be detected (Figure S14).

The configuration around the C-10/C-12 double bond was determined considering the size of the  $^3J_{\text{C}11\text{H}12}$  and  $^3J_{\text{C}9\text{H}12}$  couplings as estimated by CLIP-selHSQMBC and a selective SJS-scaled BIRD experiment (Figure S11 and S12). In both measurements, the  $^3J_{\text{C}9\text{H}12}$  coupling was larger than the  $^3J_{\text{C}11\text{H}12}$  coupling, which is consistent with a Z-

configuration of the double bond (*i.e.* the proton and the methyl in *cis*). This was confirmed by a clear NOE between H-12 ( $\delta_{\text{H}}$  5.74) and H<sub>3</sub>-11 ( $\delta_{\text{H}}$  1.84).

### 2.3. Evaluation of the bioactivity of **1**

Compound **1** is structurally related to the synthetically produced and commercially available antimicrobial compound lauric arginate (**2**) (Ma et al. 2013) as well as the cytotoxic natural product spermidine **1** (**3**) (Schmitz et al. 1979) isolated from the soft coral *Sinularia brongersmai* (Figure S3). Compound **2** is active against both gram positive and gram negative bacteria, and against biofilm formation. Compound **3** is active against various cancer cell lines found in the National Cancer Institute 60-cell line panel at sub- $\mu\text{M}$  concentrations.

Amphipathic structures, consisting of a lipophilic chain and a charged region often act as surface-active molecules on biological membranes (Schreier et al. 2000; Schmidt and Wong 2013). Because of the structural features of **1** and its similarity to **2** and **3**, the compound was tested for activity in a variety of bioactivity assays. Compound **1** was assayed against the cancer cell line A2058 and the non-malignant human lung fibroblasts cell line MRC-5, but displayed no effect at 10  $\mu\text{M}$ . When evaluated for antimicrobial activity, **1** showed no activity at the highest assayed concentration (135.68  $\mu\text{M}$ ) against *S. aureus*, *E. coli*, *P. aeruginosa*, *E. faecalis* or *S. agalactiae* (gr.B) and *C. albicans*, nor against the ability of *S. epidermis* to form biofilm. Furthermore, **1** was evaluated for its ability to inhibit the release of the cytokine tumor necrosis factor (TNF $\alpha$ ) from the human acute leukemia monocyte cell line (THP-1) at 10  $\mu\text{M}$ . Compound **1** did not show anti-inflammatory effect. Compound **1** was evaluated for its antioxidant effect at 135.68  $\mu\text{M}$   $\mu\text{g}$  using an oxygen radical absorbance capacity (ORAC) assay and no significant effect was observed. The bioactivities of the similar compounds **2** and **3** could thus not be found in **1**.

All the three compounds share a C<sub>12</sub> fatty acid chain, where **1** and **2** have a double bond between C-10 and C-12, and thus are monounsaturated. However, the stereochemistry around the double bond is different as **1** has *cis* while **3** has *trans* configuration. The presence of a double bond in **1** and **3** makes these structures more rigid compared to **2**, which has an unsaturated fatty acid chain. Both compounds **1** and **2** contains the cationic amino acid residue arginine, but in **2** the hydroxyl group is ethylated so it can not be deprotonated and thus is not negatively charged. The zwitterionic nature of **1** may result in ionic bond formation between the negatively charged hydroxyl oxygen and positively charged guanidine group, possibly preventing **1** from integrating with the negatively charged bacterial membranes. This may explain the lack of observed antibacterial activity of **1** despite its structural resemblance to **2**. The spermidine part of **3** differ from the polar amino acid groups of **1** and **2**, as it lacks the terminal guanidine group, which is positively charged under physiological pH. Differences in observed bioactivities between **1** compared to **2** and **3** can thus be explained by presence and absence of specific substituents, differences in the overall three-dimensional structures of the compounds and possibly by an intramolecular ionic bond formation in **1**.

Reporting of natural products, despite being inactive in the selected bioassays, adds to the knowledge of the chemical diversity of invertebrate derived molecules. As production of secondary metabolites is energy consuming, the natural function of **1** is most likely to provide a beneficial effect for the producing animal, by acting as a pathogen or predator repellent, in competition for space or to protect against abiotic stress factors (Figuerola et al. 2017). Thus, it is likely that the compound is bioactive, just not in the bioactivity assays available to us (Li and Lou 2018). Future screening of **1** in a wider selection of bioassays might reveal its biological function.

#### 2.4. Dendrobeaniamine A (**1**)

Golden yellow substance;  $[\alpha]_D^{20}$   $-18.75 \pm 0.02$  ( $c$  0.16 MeOH); UV = (ACN)  $\lambda_{\max}$  223 nm; IR  $\nu_{\max}$  3279, 2936, 2363, 1726, 1626, 1544,  $\text{cm}^{-1}$ .  $^1\text{H}$  and  $^{13}\text{C}$  NMR data (see Table S1); HRMS  $m/z$  369.2861  $[\text{M} + \text{H}]^+$  (calculated for  $\text{C}_{19}\text{H}_{37}\text{N}_4\text{O}_3=369.2865$ ).

### 3. Conclusion

Chemistry guided purification of the organic extract of the Arctic marine bryozoan *D. murrayana* yielded one new compound, Dendrobeaniamine A (**1**). This compound was present in abundant amounts in the organic extract. We were not able to pinpoint the activity of this compound by the bioactivity assays available to us. The bioactivity and natural function of this compound thus remains to be elucidated.

### Acknowledgements

The authors would like to thank Marbank for marine bryozoan collection, identification, and extraction. We also would like to acknowledge the department engineers Marte Albrigtsen and Kirsti Helland for the bioactivity experiments.

### Disclosure statement

The authors declare no conflict of interest.

### References

- Blunt JW, Carroll AR, Copp BR, Davis RA, Keyzers RA, Prinsep MR. 2018. Marine natural products. Nat Prod Rep. 35(1):8–53.
- Figuerola B, Angulo-Preckler C, Nunez-Pons L, Moles J, Sala-Comorera L, Garcia-Aljaro C, Blanch AR, Avila C. 2017. Experimental evidence of chemical defence mechanisms in Antarctic bryozoans. Mar Environ Res. 129:68–75.
- Hansen KO, Isaksson J, Bayer A, Johansen JA, Andersen JH, Hansen E. 2017. Securamine derivatives from the Arctic bryozoan *Securiflustra securifrons*. J Nat Prod. 80(12):3276–3283.
- Hansen KO, Isaksson J, Glomsaker E, Andersen JH, Hansen E. 2018. Ponasterone A and F, ecdysteroids from the Arctic bryozoan *Alcyonidium gelatinosum*. Molecules. 23(6):E1481.
- Kollár P, Rajchard J, Balounová Z, Pazourek J. 2014. Marine natural products: bryostatins in pre-clinical and clinical studies. Pharm Biol. 52(2):237–242.
- Li G, Lou H-X. 2018. Strategies to diversify natural products for drug discovery. Med Res Rev. 38(4):1255–1294.

- Ma Q, Davidson PM, Zhong Q. 2013. Antimicrobial properties of lauric arginate alone or in combination with essential oils in tryptic soy broth and 2% reduced fat milk. *Int J Food Microbiol.* 166(1):77–84.
- Maltseva AL, Kotenko ON, Kutymov VA, Matvienko DA, Shavarda AL, Winson MK, Ostrovsky AN. 2017. Novel brominated metabolites from bryozoa: a functional analysis. *Nat Prod Res.* 31(16): 1840–1848.
- Michael P, Hansen KO, Isaksson J, Andersen JH, Hansen E. 2017. A novel brominated alkaloid securidine A, isolated from the marine bryozoan *Securiflustra securifrons*. *Molecules.* 22(7): E1236. [CrossRef]
- Peters L, Konig GM, Terlau H, Wright AD. 2002. Four new bromotryptamine derivatives from the marine bryozoan *Flustra foliacea*. *J Nat Prod.* 65(11):1633–1637.
- Ryland JS. 2005. Bryozoa: an introductory overview.
- Schmidt NW, Wong GCL. 2013. Antimicrobial peptides and induced membrane curvature: geometry, coordination chemistry, and molecular engineering. *Curr Opin Solid State Mater Sci.* 17(4):151–163.
- Schmitz FJ, Hollenbeak KH, Prasad RS. 1979. Marine natural products: cytotoxic spermidine derivatives from the soft coral *Sinularia brongersmai*. *Tetrahedron Lett.* 20(36):3387–3390.
- Schreier S, Malheiros SVP, de Paula E. 2000. Surface active drugs: self-association and interaction with membranes and surfactants. *Physicochemical and biological aspects. Biochim Biophys Acta.* 1508(1-2):210–234.
- Svenson J. 2013. MabCent: Arctic marine bioprospecting in Norway. *Phytochem Rev.* 12(3): 567–578.
- Tadesse M, Tabudravu JN, Jaspars M, Strom MB, Hansen E, Andersen JH, Kristiansen PE, Haug T. 2011. The antibacterial ent-eusynstyelamide B and eusynstyelamides D, E, and F from the Arctic bryozoan *Tegella cf. spitzbergensis*. *J Nat Prod.* 74(4):837–841.
- Tian XR, Tang HF, Tian XL, Hu JJ, Huang LL, Gustafson KR. 2018. Review of bioactive secondary metabolites from marine bryozoans in the progress of new drugs discovery. *Future Med Chem.* 10(12):1497–1514.
- Yu CM, Wright JL. 1995. Murrayanolide, an unusual C21 tetracyclic terpenoid lactone from the marine bryozoan *Dendrobeatia murrayana*. *J Nat Prod.* 58(12):1978–1982.

## SUPPLEMENTARY MATERIAL

### **Dendrobeaniamine A, a New Alkaloid from the Arctic Marine Bryozoan *Dendrobeatia murrayana***

Priyanka Michael<sup>1</sup>, Espen Hansen<sup>1</sup>, Johan Isaksson<sup>2</sup>, Jeanette H. Andersen<sup>1</sup> and  
Kine Ø. Hansen<sup>1,\*</sup>

<sup>1</sup>*Marbio, UiT–The Arctic University of Norway, Breivika, Tromsø N-9037, Norway*

<sup>2</sup>*Department of Chemistry, UiT–The Arctic University of Norway, Breivika, Tromsø N-9037,  
Norway*

\*Corresponding author

E-mail: kine.o.hanssen@uit.no

#### **Abstract**

The new guanidine alkaloid Dendrobeaniamine A (**1**) was isolated from the organic extract of the Arctic marine bryozoan *Dendrobeatia murrayana*. The chemical structure of **1** was elucidated by spectroscopic experiments, including 1D and 2DNMR and HRESIMS analysis. Compound **1** is a lipoamino acid, consisting of a C<sub>12</sub> fatty acid anchored to the amino acid arginine. The bioactivity of **1** was evaluated using cellular and biochemical assays, but the compound did not show cytotoxic, antimicrobial, anti-inflammatory or antioxidant activities.

#### **Key words**

Arctic marine invertebrates; bryozoans; *Dendrobeatia murrayana*; bioprospecting; marine secondary metabolites.

## 4. Experimental section

### 4.1 General experimental procedure

High-resolution mass spectra were acquired using positive electrospray ionization on a Waters Vion<sup>®</sup> IMS time-of-flight MS coupled with an Acquity I-Class UPLC (Waters, Milford, MA, USA) using MS grade solvents. The system was controlled and data was processed using UNIFI 1.8.2. Isolation of **1** was done using a HPLC autopurification system consisting of Waters 600 pump, Waters 3100 mass spectrometer, Waters 2996 photo diode array detector and Waters 2767 sample manager. The prep-HPLC system was controlled by Waters MassLynx version 4.1 and the FractionLynx application manager.

### 4.2 Animal material

Specimens of the marine bryozoan *Dendrobeania murrayana* (Johnston 1847) (Class: Gymnolaemata, Order: Cheilostomata, Family; Bugulidae) were collected by scuba diving during the spring of 2012 at 30 m depth in Vesterålsfjorden, Norway (69° 26.177 N/14°, 93.773 W). The marine organism was taxonomically identified and kept at -23°C until extracted. A voucher specimen (M17034) of *D. murrayana* is deposited in Marbank, the Norwegian national marine biobank (Institute of marine research, Tromsø, Norway).

### 4.3. Extraction

Frozen specimens of *D. murrayana* (wet weight 0.55 kg) were diced and freeze dried before being extracted twice (first time 24 h, second time 30 min) using ultra-pure water (Milli-Q, Millipore, Billerica, MA, USA). After centrifugation the supernatant was removed and dried, resulting in 17.84 g aqueous extract. The sediment was freeze-dried, ground and extracted twice (first time 24 h, second time 30 min) using a 1:1 (vol:vol) mixture of dichloromethane (Merck, Darmstadt, Germany) and methanol (Sigma-Aldrich, Steinheim, Germany). The mixture was vacuum-filtered through a Whatman Ø 125 mm no.3 filter (Little Chalfont, UK). The organic extract was reduced under vacuum, resulting in 1.59 g dry organic extract, and stored at -23°C in the dark awaiting further analysis.



#### 4.4. Preparation of the organic extract for chemical analysis

An aliquot of the organic extract (0.75 g) was dissolved in 30 mL hexane (Merck) and partitioned three times with 25 mL 90% aqueous methanol in a separating funnel. The combined methanol phases were finally reduced to dryness under reduced pressure at 40°C and redissolved in 4 mL 80% aqueous methanol

#### 4.5. UHPLC-DAD-HRESIMS analysis

UHPLC-HRESIMS was used to analyse the prepared organic extract. An aliquot of 5  $\mu$ L of the prepared sample was injected onto a Waters Acquity BEH C18 column (1.7  $\mu$ m, 2.1  $\times$  100 mm, 40 °C). The mobile phase consisted of ultra-pure water (solvent A) and acetonitrile (solvent B) (Merck, Darmstadt, Germany), both with 0.1% formic acid (Pro-analysis, Merck, Darmstadt, Germany) delivered at a flow rate of 0.45 mL/min. The gradient started with 10% B and was linearly increased to 100% B over 12 min. The HRESIMS data was obtained in positive electrospray ionization (ESI+) mode with a data acquisition rate of 10 scans per second at a mass range of  $m/z$  50-2000. The HRESIMS was operated under following conditions: The capillary and cone voltages were set to 0.8 kV and 40 V, respectively. The desolvation and ion source temperatures were set to 350°C and 120°C, respectively. Nitrogen gas was used for desolvation at 800 L/h and cone gas at 50 L/h. UV-data was acquired between 190 and 500 nm. Leucine-enkephalin (100 pg/ $\mu$ L) (Waters, Milford, MA, USA) in 50% aqueous acetonitrile with 0.1% formic acid was used for lock mass correction. ChemSpider, Dictionary of Marine Natural Products and SciFinder were used for database searches.

#### 4.6. Isolation of **1** using mass guided semi preparative HPLC

Compound **1** was isolated by using a Waters preparative HPLC auto-purification system. The mass of protonated dendrobeaniamine A (**1**) (369.3 Da) was used as collection trigger in ESI+ mode. Aliquots of 100  $\mu$ L were injected onto a Waters Atlantis® prep C18 HPLC column (10  $\mu$ m, 10 mm  $\times$  250 mm). The mobile phase consisted of ultrapure water (A) and acetonitrile (B) both with 0.1% formic acid, applied at a flow rate of 6 mL/min. The gradient started with 50% B and was linearly increased to 80% B over 10 min. Compound **1** eluted after 5.3 min. One percent of the flow was split to the MS. After drying and redissolving the sample, it was

injected once more onto a Waters X-Select fluorophenyl column (5  $\mu\text{m}$ , 10 mm $\times$ 250 mm) with the same flow rate and gradient. The final yield of **1** was 2.5 mg.

#### 4.7. Structure determination of **1**

Optical rotation data was obtained using an AA-10R automatic polarimeter (Optical Activity LTD). The IR spectrum was measured on a NaCl disk using a Cary 630 FT-IR spectrometer (Agilent technologies, CA, USA). NMR spectra were acquired in deuterated methanol on a Bruker Avance III HD spectrometer operating at 600 MHz for protons, equipped with an inverse TCI cryo probe enhanced for  $^1\text{H}$ ,  $^{13}\text{C}$ ,  $^2\text{H}$  and  $^{15}\text{N}$ . All NMR spectra were acquired at 298 K, in 3 mm solvent matched Shigemi tubes using standard pulse programs for proton, carbon, HSQC, HMBC, H2BC, DQCOSY, TOCSY and NOESY with gradient selection and adiabatic versions where applicable.

#### 4.8 Bioassays

##### 4.8.1. Cytotoxic assay (MTS assay)

The cytotoxic activity of **1** was tested at 10  $\mu\text{M}$  against human melanoma A2058 cells (American Type Culture Collection (ATCC) CRL-1114, Manassas, VA, USA) and non-malignant human MRC5 lung fibroblasts (ATCC CCL-171) using by the MTS method as previously described (Hansen et al. 2017; Michael et al. 2017).

##### 4.8.2. Antibacterial activity

The antibacterial activity of **1** was tested at ranging concentrations starting from 135.68  $\mu\text{M}$  against *Staphylococcus aureus* (ATCC 25923), *Escherichia coli* (ATCC 25922), *Pseudomonas aeruginosa* (ATCC 27853), *Enterococcus faecalis* (ATCC 29212) or *Streptococcus agalactiae* (gr.B) (ATCC 12386) as previously described (Michael et al. 2017).

##### 4.8.3. Antifungal activity assay

The antifungal activity of **1** was tested at 135.68  $\mu\text{M}$  against *Candida albicans* (ATCC 90028) using a broth dilution assay. *C. albicans* was inoculated on a potato dextrose broth containing dextrose (20.0 g), potato extract (4.0 g), agar (15.0 g) and pH 5.6 $\pm$ 0.2) and incubated at 37°C for 24 hrs. From the subculture, 5-8 colonies were picked and resuspended in 5 mL of sterile 0.9% NaCl (Sigma), vortexed for 15 seconds and adjusted to a density of 0.5 McFarland standard. Thereafter, the inoculum was further diluted in the sterile assay medium to achieve the final concentration at 0.5-2.5  $\times 10^6$  CFU/mL. The assay medium contained Roswell Park Memorial Institute (RPMI) powder without bicarbonate (Sigma-Aldrich) (10.4 g), L-glutamine (Biochrom, Berlin, Germany) (10.25 mL), MOPS buffer (Sigma-Aldrich) (34.53 g), pH 7 and distilled water (900 mL). The fungal cell suspension of 100  $\mu\text{L}$  was transferred to a 96 microtitre plate (Nunclon™ Delta Surface, Thermo Fisher Scientific, Denmark) followed by the addition of 100  $\mu\text{L}$  of **1** in triplicate. Prior to incubation at 37°C, the optical density was measured immediately at 600 nm ( $\text{OD}_{600}$ ) by using Victor<sup>3</sup> plate reader with WorkOut 2.0 software. After 48 hrs incubation, the  $\text{OD}_{600}$  was measured once more. Amphotericin B (A2942 Sigma) (8  $\mu\text{g}/\text{mL}$ ) was used as a reference control, culture with sterile MilliQ was used as positive control and assay medium with sterile Milli-Q water was used as negative control.  $\text{OD}_{600}$  readings  $< 0.05$  was considered as active.

#### 4.8.4. Biofilm inhibition assay

The inhibition of biofilm formation by **1** was tested at 135.68  $\mu\text{M}$  against *Staphylococcus epidermidis* (ATCC-35984 RP62A-42-77). The assay was performed as previously described (Michael et al. 2017).

#### 4.8.5. Anti-inflammatory assay

THP-1, a human acute leukemia monocytic cell line (ATCC TIB-202, Manassas, VA, USA) was used to study an inhibition of lipopolysaccharide (LPS) induced cytokines secretion of tumor necrosis factor ( $\text{TNF-}\alpha$ ) by **1** at 10  $\mu\text{M}$ . THP-1 cells were cultured and assayed in low endotoxin RPMI-1640 (Biochrome GmbH, Germany), supplemented with fetal bovine serum (10%) (Ultralow endotoxin, Biowest), gentamycin (10 mg/mL) and L-alanyl-L-glutamine (200 mM) (Biochrome). Briefly,  $1 \times 10^5$  cells/well were seeded in a flat bottom Nunc™ 96 microtitre plate (Thermo Fisher Scientific, Denmark) and the cells were immediately treated

with 50 ng/mL phorbol 12-myristate 13-acetate (PMA) (Sigma) for monocyte to macrophage differentiation. Following incubation at 5% CO<sub>2</sub> and 37°C for 48 hrs, cells were washed with endotoxin free tris buffered saline (TBS- 0.05% Tween-20; pH 7.4) and replaced with 100 µL of new RPMI growth medium before 24 hrs incubation. The old medium was replaced with 80 µL fresh RPMI growth medium and the cells were treated with 10 µL of test **1** in triplicate. Cell control wells were incubated with growth medium alone. After 1 hr incubation, the cells were stimulated with 10 µL of 10 ng/mL LPS to all wells except the negative control. Positive control were cells treated with LPS in growth medium. The plate was incubated for another 6 hrs at 37°C. Cytokine production was stopped by freezing the plates at -80°C immediately after incubation. TNF- $\alpha$  concentration in the collected supernatants was measured by sandwich Enzyme-linked immunosorbent assay (ELISA). One day prior to the ELISA test, a 96-well flat-bottom Nunc Maxisorp plate was coated with 2 µg/mL capture antibody (eBioscience, San Diego, CA, USA) in TBS and kept at 4°C for overnight. The coating solution was washed twice with TBS at room temperature. A blocking buffer (TBS; 2% BSA) 200 µL was added to each well and incubated at room temperature for an hr with gentle shaking. A TNF- $\alpha$  serial dilution (1000, 500, 250, 125, 62, 7, 31.5, 15, 6 and 0 pg/mL) was used as standard curve. After TBS washing, 50 µL of biotin conjugated antibody (3 µg/mL) (eBiosciences) (diluted in assay diluent - TBS with 1% BSA) was added to each well and incubated at 37°C for one hr. The substrate reagent ExtrAvidin<sup>®</sup> - Alkaline phosphatase (Sigma-Aldrich) was added after washing the wells with TBS. After 30 min incubation, each well was washed thoroughly with TBS (5 times wash in 30 sec interval). Simultaneously, 100 µL of substrate pNPP (1 mg/mL in 1 M diethanolamin buffer pH 9.8, Sigma-Aldrich) was added to each well and incubated at 37°C for 45 min. After color development, the absorbance was read at 405 nm by using an ELISA plate reader. Inhibition of inflammatory activity below 50 % compared to LPS positive control was considered active.

#### 4.8.6. Antioxidant assay (Oxygen Radical Absorbance Capacity (ORAC) assay)

The ORAC assay was carried out in a black polystyrene 96 well microtiter plate (FluoroNunc<sup>™</sup> MaxiSorp Surface, TX, USA). The antioxidant activity was measured against a peroxy radical generated by thermal decomposition of AAPH (2,2'-Azobis(2-amidinopropane)

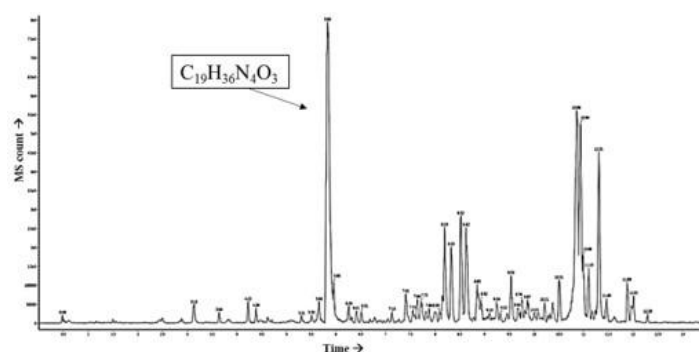
dihydrochloride) at 37°C in the presence of fluorescein. Fluorescence was measured at 485 nm excitation and 528 nm emission on a Victor<sup>3</sup> plate reader with WorkOut 2.5 software. Results were calculated from the area under the fluorescence decay curve (AUC) subtracted AUC<sub>blank</sub> values. Working solution AAPH (44 mM), fluorescein (52 nM) and Trolox® (6-hydroxy-2,5,7,8-tetramethylchroman-2-carboxylic acid) (0-25 μM) were prepared in a phosphate buffer (75 mM, pH 7.4) Compound **1** was diluted in 75 mM phosphate buffer and the final test concentration of **1** was 135.68 μM. All reagents were purchased from Sigma-Aldrich. A standard curve was derived from a Trolox titration (0-25 μM). Phosphate buffer (75 mM) was used as blank. Compound **1** was transferred to the wells in parallel followed by addition of 125 μL of fluorescein to all wells including controls. The plate was allowed to equilibrate by incubating at 37°C for 15 min. The reactions were initiated by adding 60 μL of AAPH to the preincubated microtitre plate. The fluorescence readings were recorded every 70 sec 25 times. Antioxidant activity was expressed as trolox equivalents.

**Table S1.** NMR spectroscopic data recorded for dendrobeniamine A (**1**)

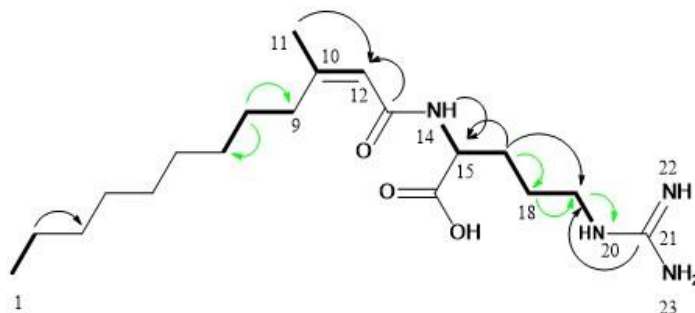
Position	$\delta_C/\delta_N$ , type	$\delta_H$ (J in Hz)	COSY	HMBC	H2BC	NOESY
1	14.4, CH <sub>3</sub>	0.89, t (6.8)	2	2		2
2	23.6, CH <sub>2</sub>	1.29 <sup>o</sup>	1	1, 3		1
3	33.0, CH <sub>2</sub>	1.26 <sup>o</sup>		1		
4	30.8, CH <sub>2</sub>	1.32 <sup>o</sup>				
5	30.7, CH <sub>2</sub>	1.29 <sup>o</sup>				
6	30.6, CH <sub>2</sub>	1.29 <sup>o</sup>				
7	30.4, CH <sub>2</sub>	1.29 <sup>o</sup>	8	8 <sup>o</sup> , 9		9
8	29.4, CH <sub>2</sub>	1.46, p (6.2)	9, 7	7, 9	7, 9	9, 11
9	33.9, CH <sub>2</sub>	2.60, m <sup>b</sup>	8	7, 8, 11, 12	8	7, 8, 11
10	155.9, C			8, 9, 11, 12		
11	24.8, CH <sub>3</sub>	1.84, s	12	9, 12	12	8, 9, 12
12	119.8, CH	5.74, s	11	9, 11		11, 14
13	168.7, C			11, 12		
14	127.7, NH	7.40, s <sup>b</sup>	15			12
15	53.1, CH	4.32, s <sup>b</sup>	17a, 17b, 14			
16	169.6, C					
17a	31.2, CH <sub>2</sub>	1.87, m <sup>b</sup>	15	18, 19	18	
17b		1.72, m <sup>b</sup>	15			
18	26.1, CH <sub>2</sub>	1.63, m <sup>b</sup>	17a, 17b, 19	17, 19	19	19
19	42.2, CH <sub>2</sub>	3.21, m	18, 20	17, 18	18, 20	18
20	84.1, NH	7.55, s <sup>b</sup>	19	18 <sup>*</sup>		
21	158.7, C			19		

<sup>o</sup>Overlapped, <sup>b</sup>Broadened, <sup>\*</sup>in <sup>15</sup>N HMBC spectrum

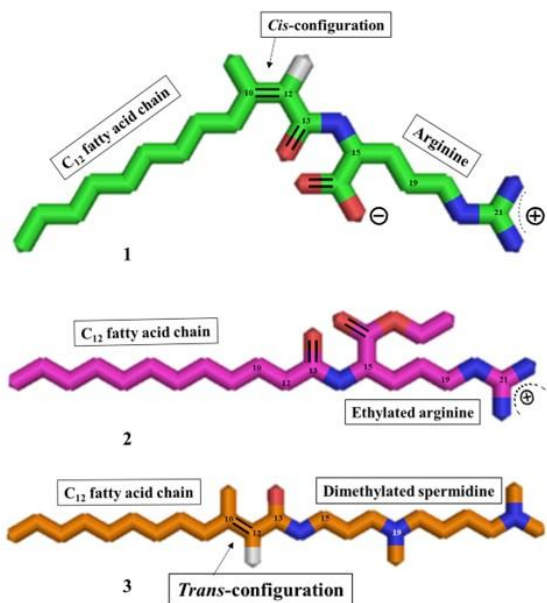
**Figure S1.** ESI+ base peak intensity chromatogram of the organic extract of *D. murrayana* analyzed by UHPLC-HRESIMS. The arrow indicates the prominent peak at Rt 5.7 min.



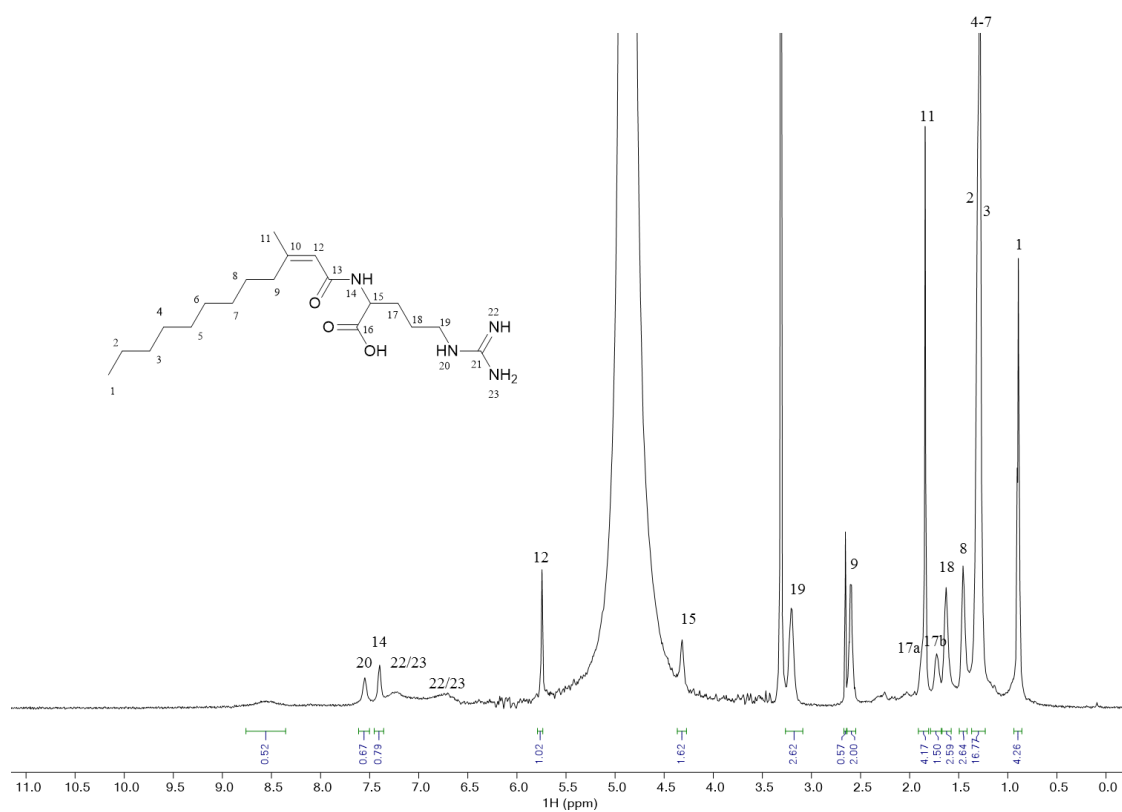
**Figure S2.** Structure of **1** was elucidated as new alkaloid dendrobeaniamine A. Highlighted is key COSY (bold), HMBC (black arrows) and H2BC (green arrows) correlations for **1**.



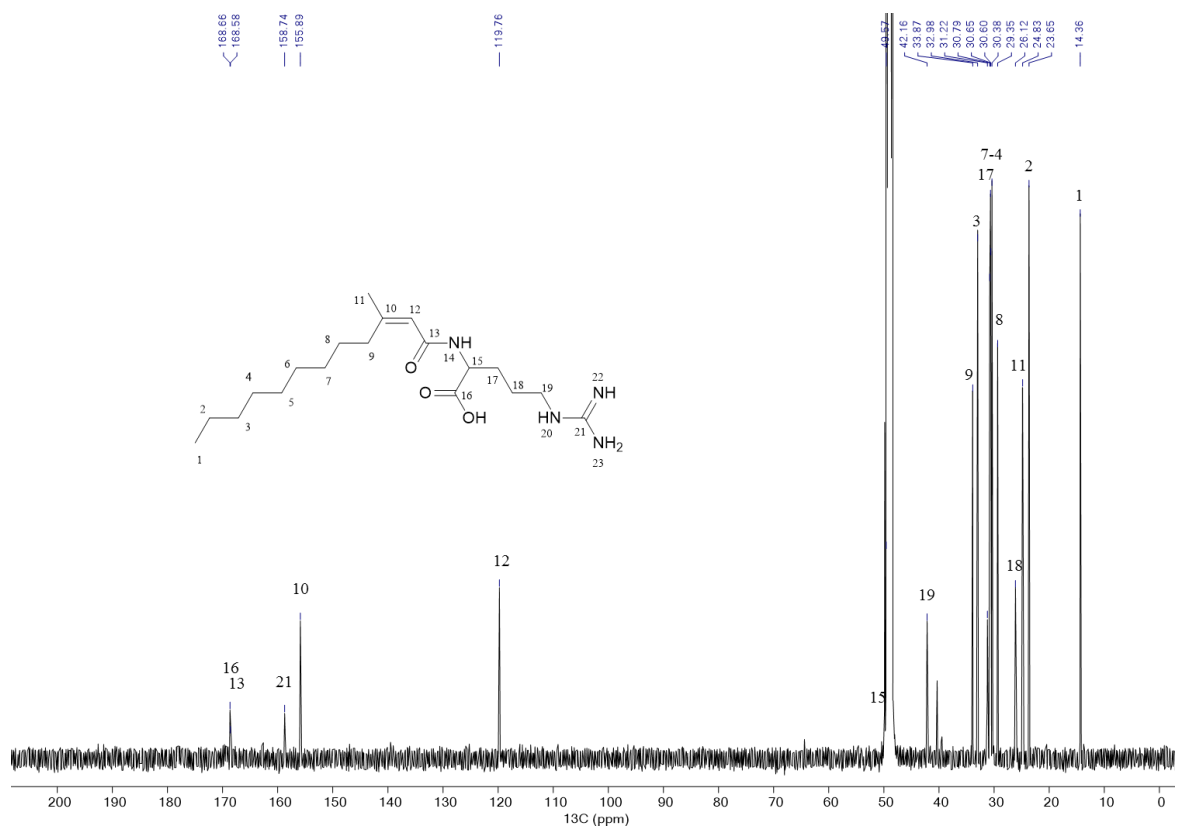
**Figure S3.** The structures of **1** (green), lauric arginate (**2**, pink) and spermidine 1 (**3**, orange) with highlighted key structural features. Charge: + and -, oxygen: red, nitrogen: blue, hydrogen: white, double bond: =.



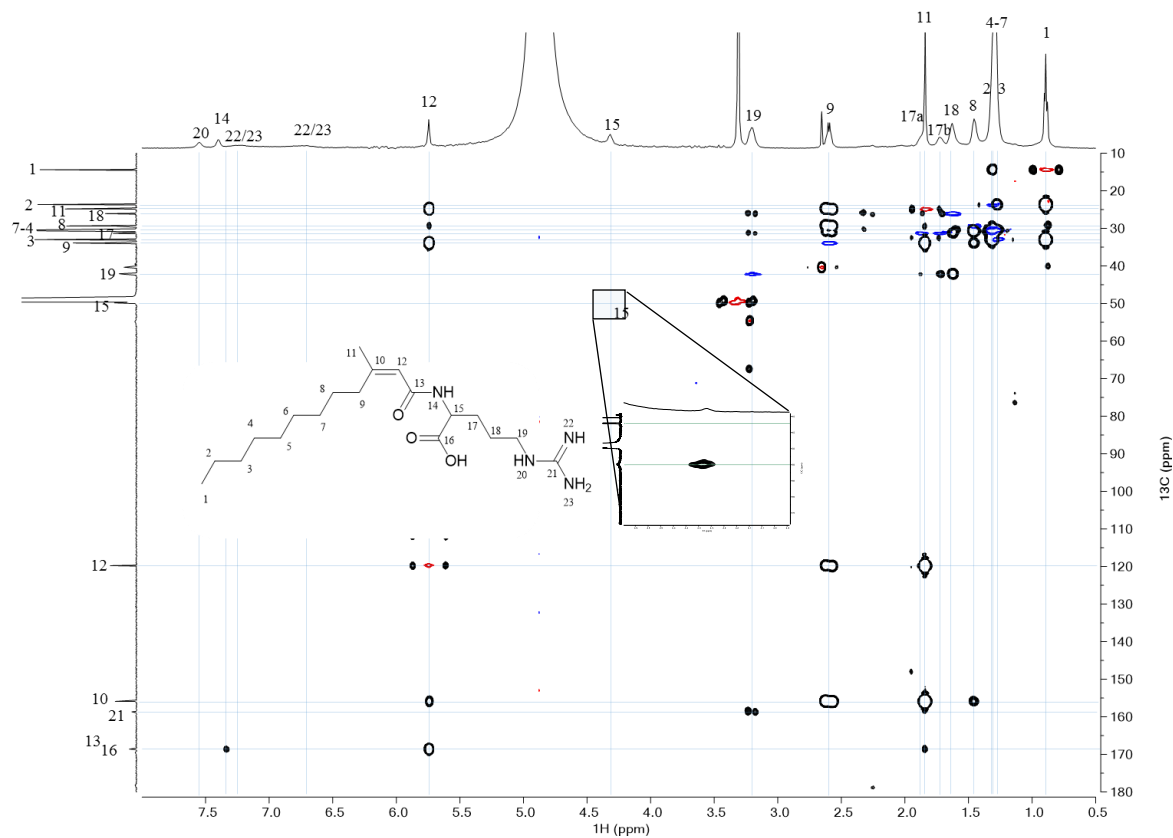
**Figure S4.**  $^1\text{H}$  NMR (600 MHz,  $\text{CD}_3\text{OD}$ ) spectrum of Dendrobeaniamine A (**1**)



**Figure S5.**  $^{13}\text{C}$  (151 MHz,  $\text{CD}_3\text{OD}$ ) spectrum of Dendrobeaniamine A (**1**)

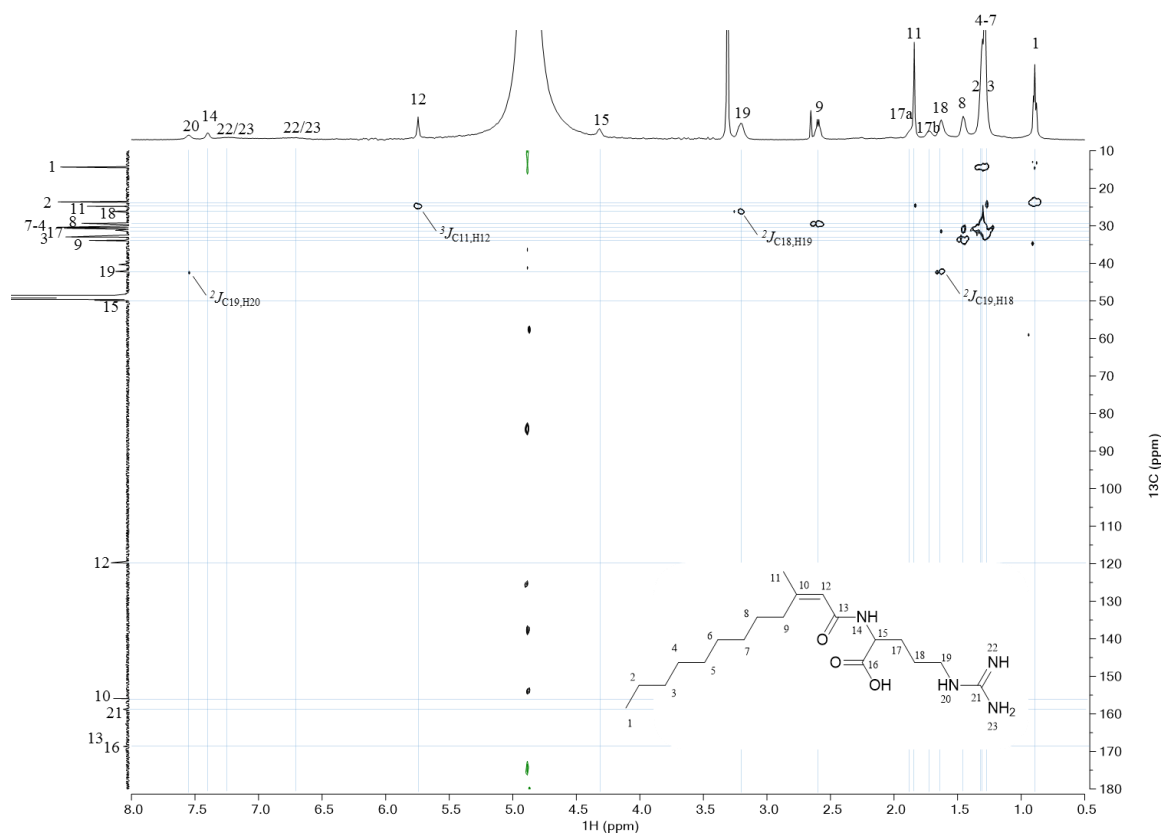


**Figure S6.** HSQC + HMBC (600 MHz, CD<sub>3</sub>OD) spectrum of Dendrobeaniamine A (**1**). The inlaid figure is the <sup>1</sup>J<sub>C15H15</sub> HMBC that is not detected in the HSQC.

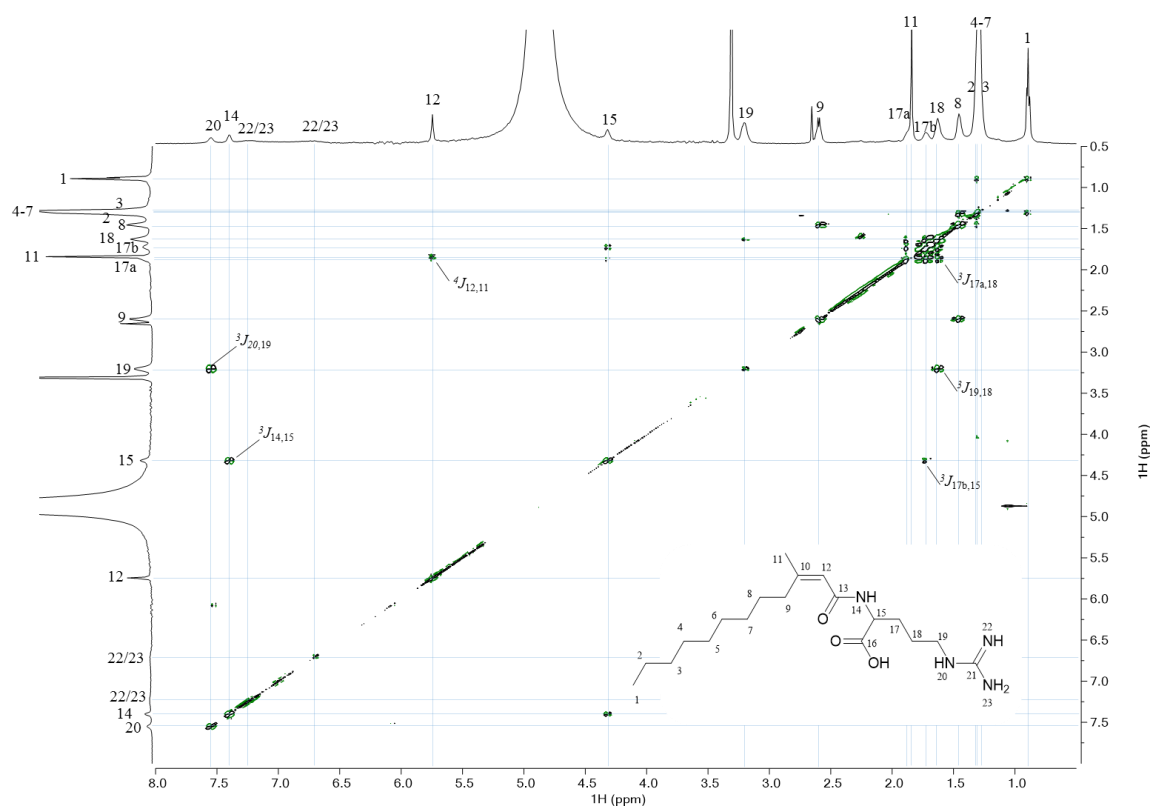


**Figure S7.** H<sub>2</sub>BC (600 MHz, CD<sub>3</sub>OD) spectrum of Dendrobeaniamine A (**1**)

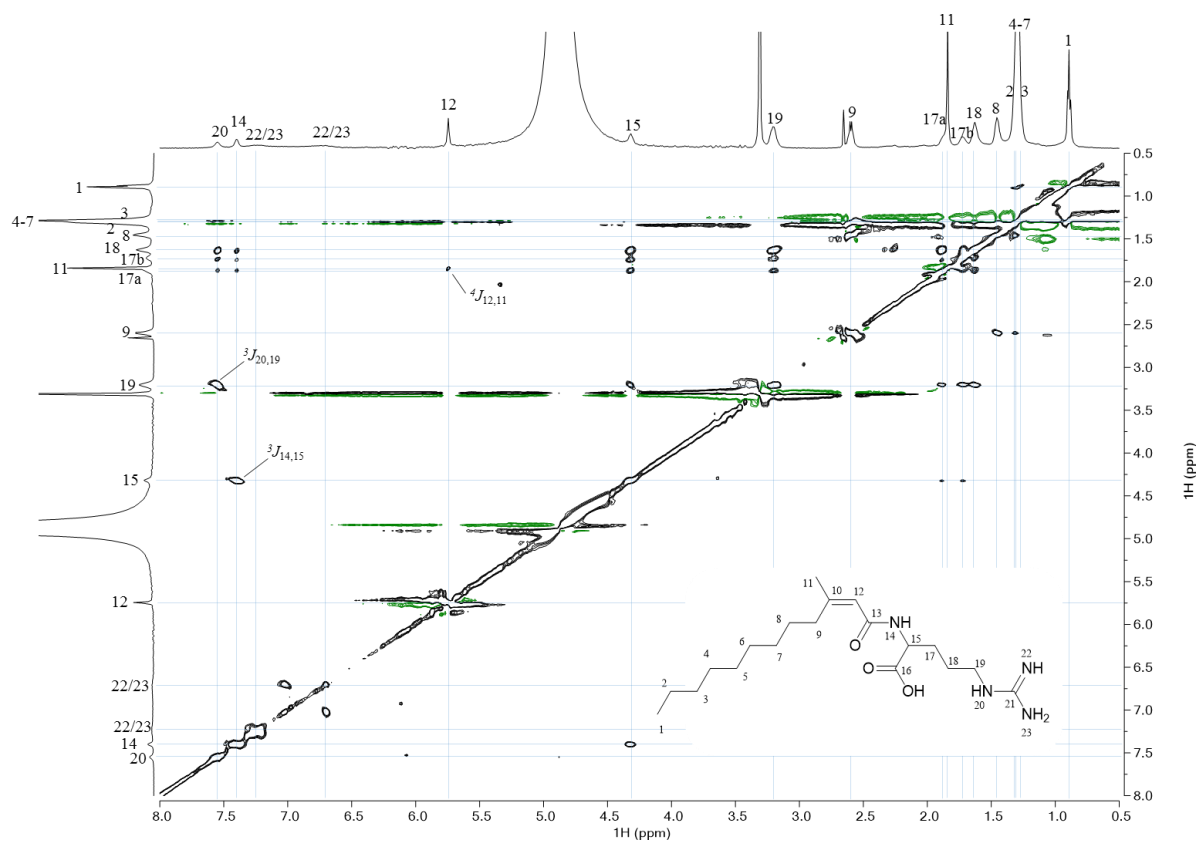




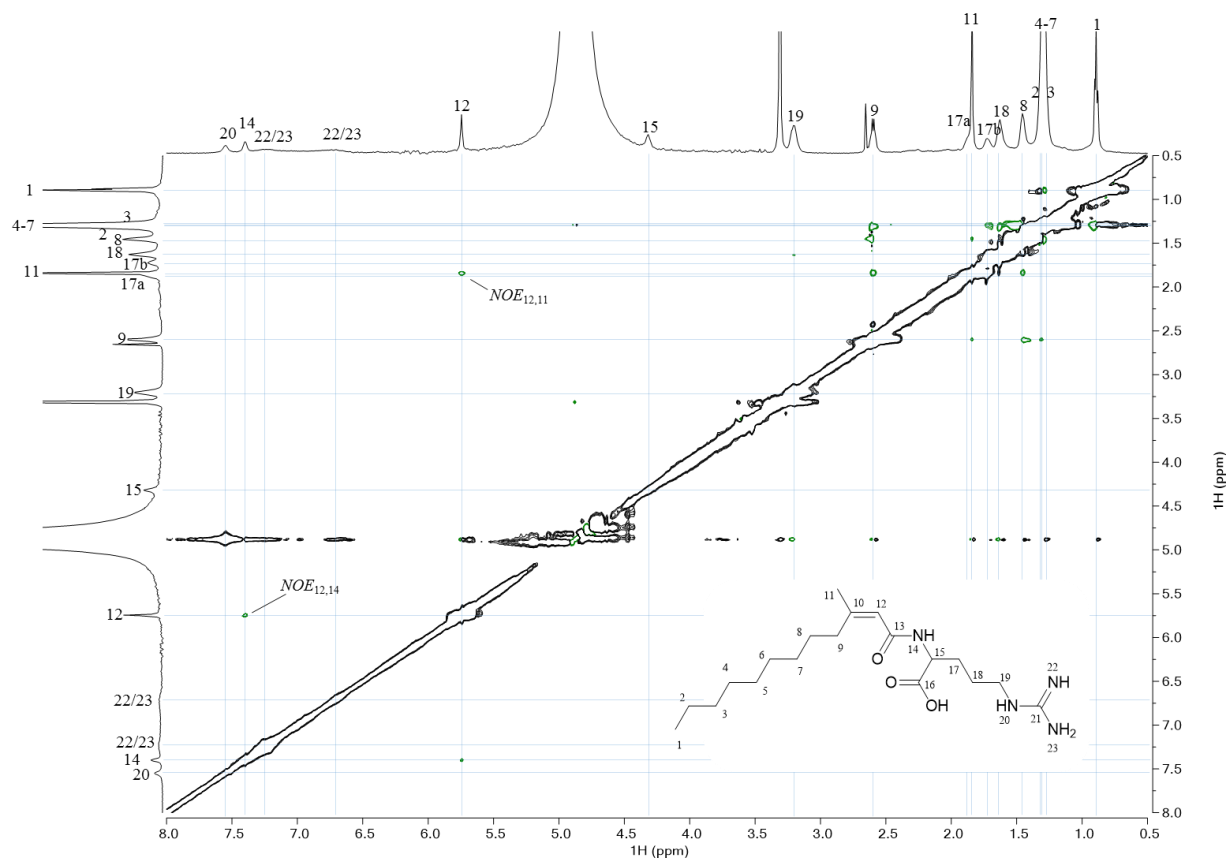
**Figure S8.** COSY (600 MHz, CD<sub>3</sub>OD) spectrum of Dendrobeaniamine A (1)



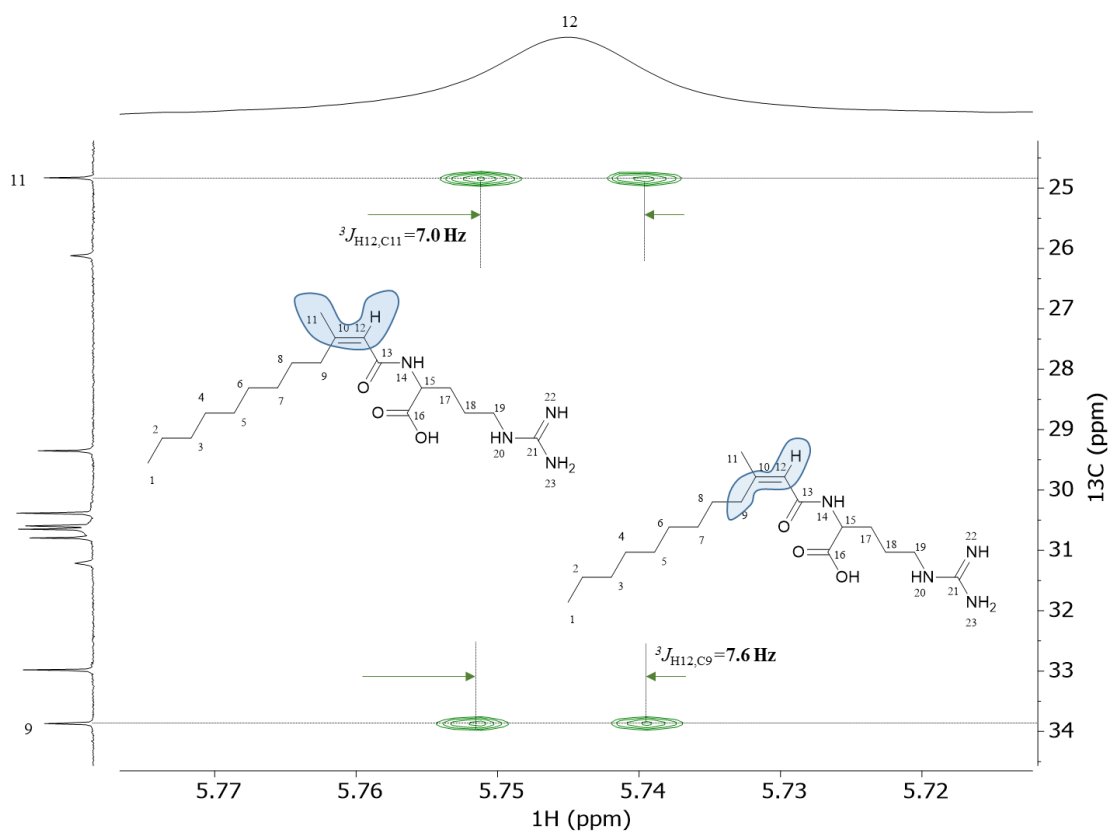
**Figure S9.** TOCSY (600 MHz, CD<sub>3</sub>OD) spectrum of Dendrobeaniamine A (1)



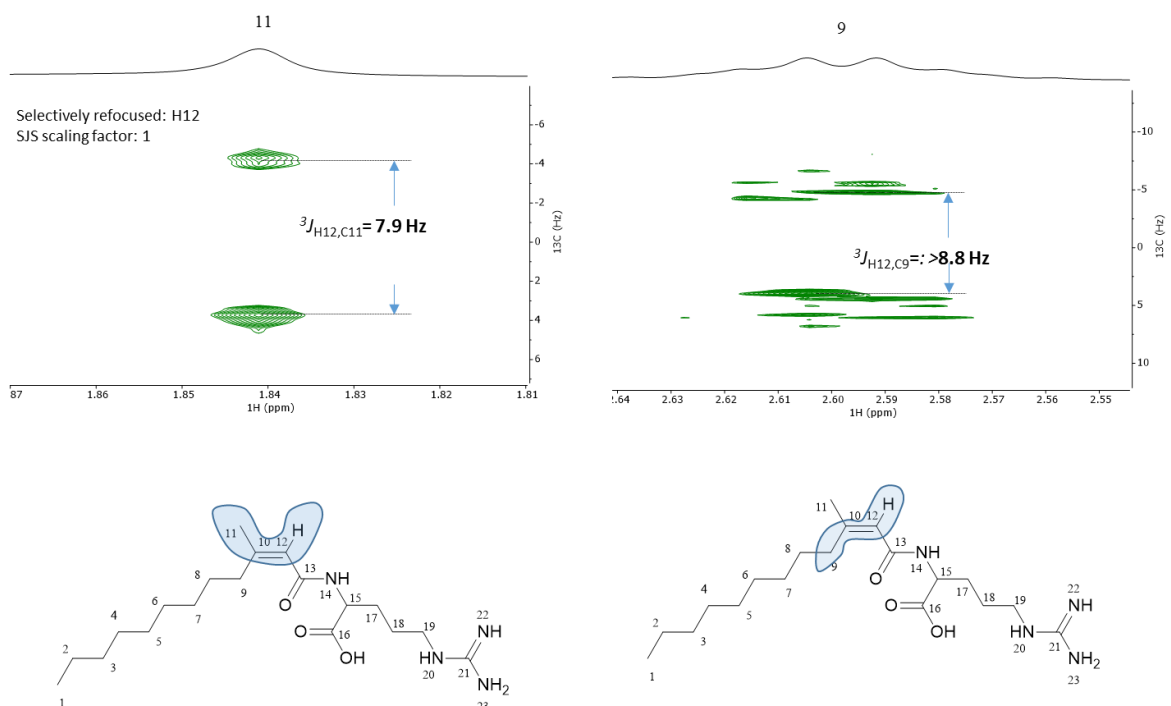
**Figure S10.** NOESY (600 MHz, CD<sub>3</sub>OD) spectrum of Dendrobeaniamine A (**1**)



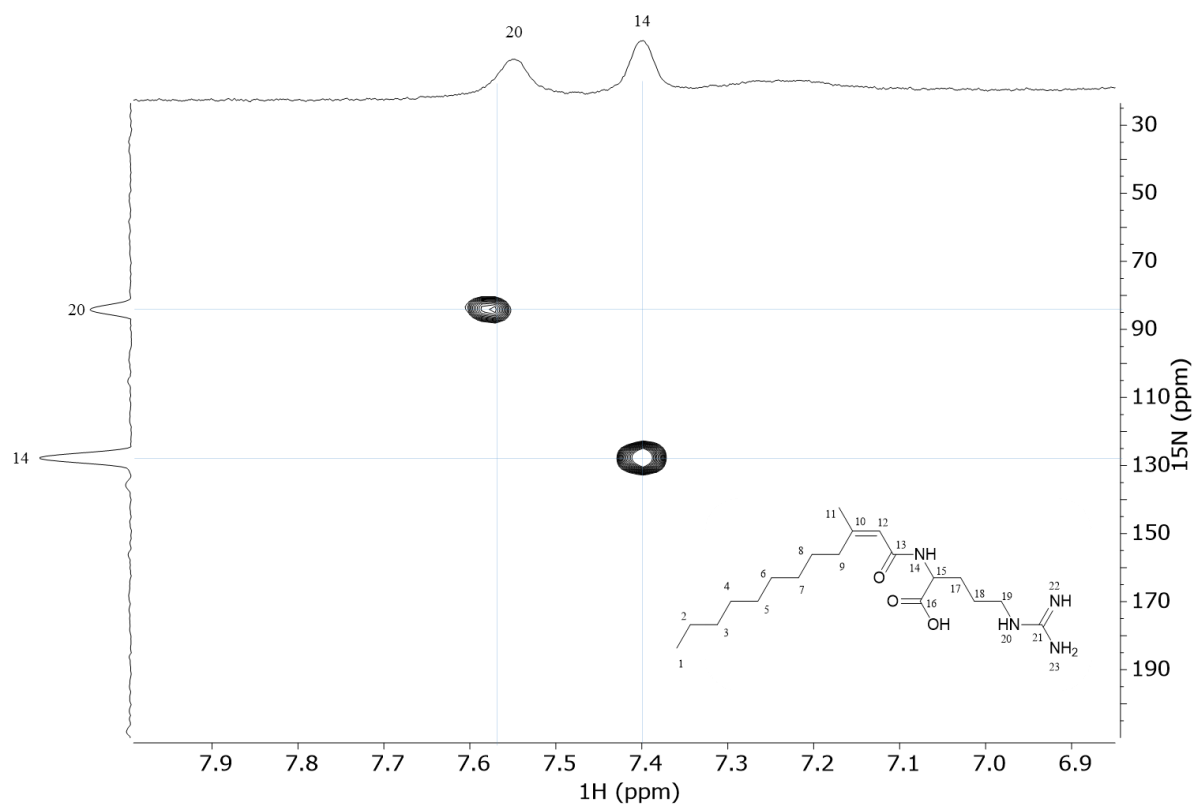
**Figure S11.** CLIP-sel HSQMBBC (600 MHz, CD<sub>3</sub>OD) spectrum of H-12 of Dendrobeaniamine A (**1**)



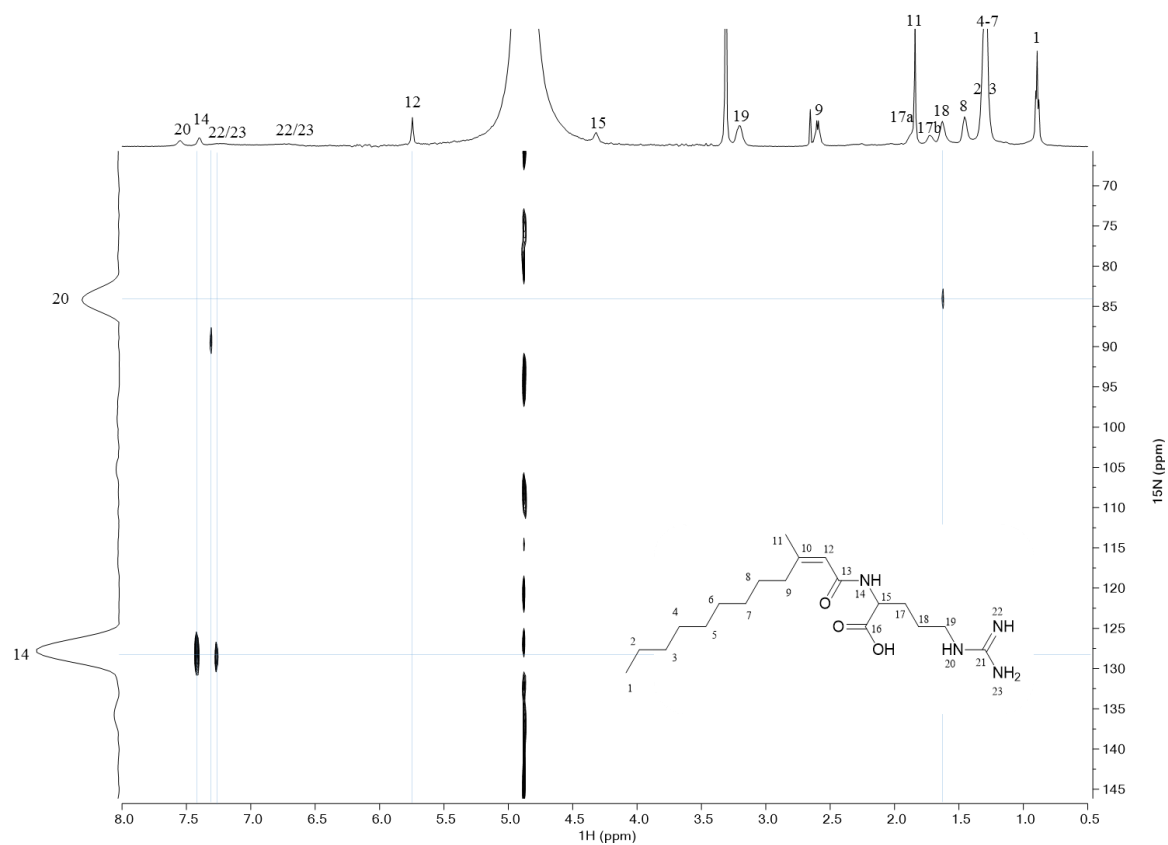
**Figure S12.** J-resolved SJS-BIRD spectrum (600 MHz, CD<sub>3</sub>OD) (Sel. Inv: H-12) of Dendrobeaniamine A (**1**)



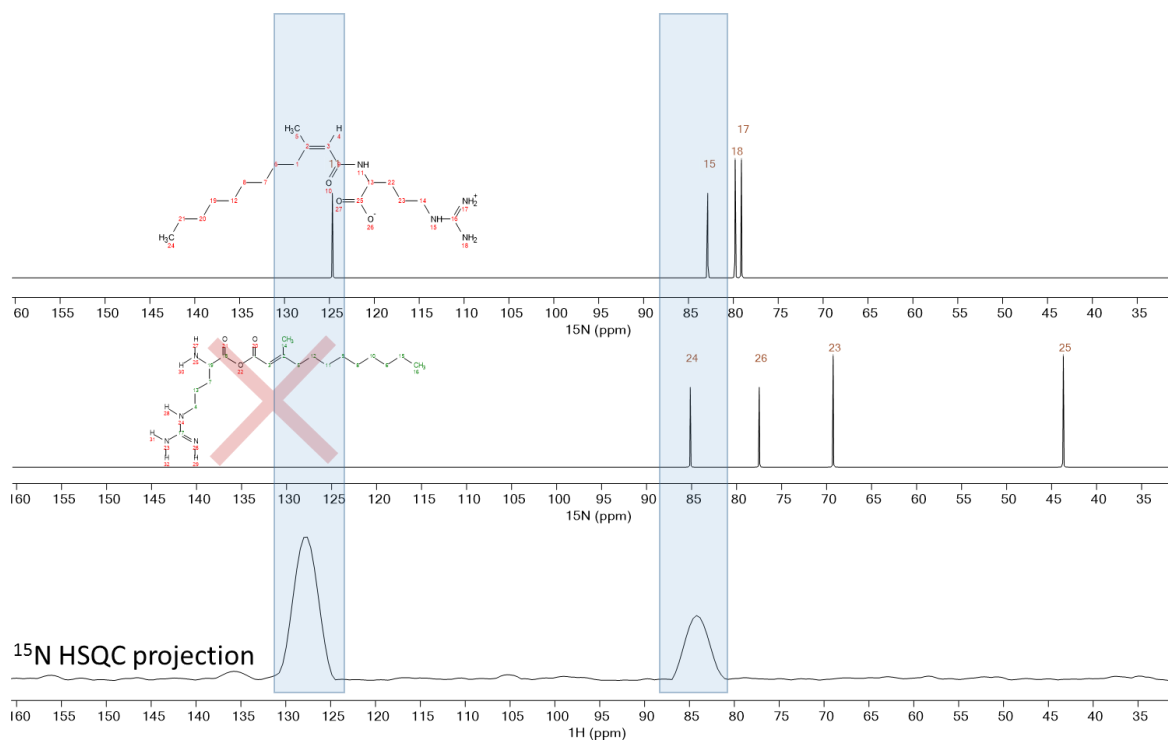
**Figure S13.** <sup>15</sup>N HSQC (600 MHz, CD<sub>3</sub>OD) spectrum of Dendrobeaniamine A (**1**)



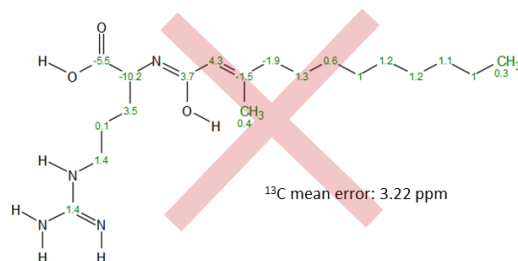
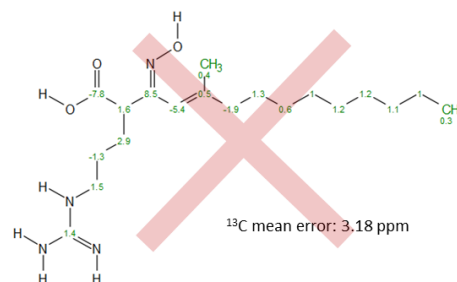
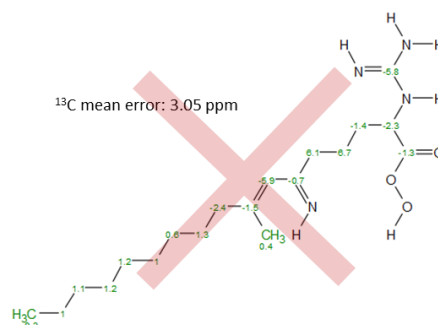
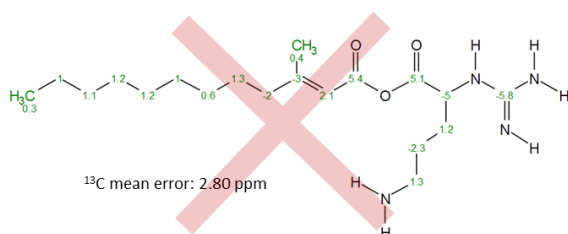
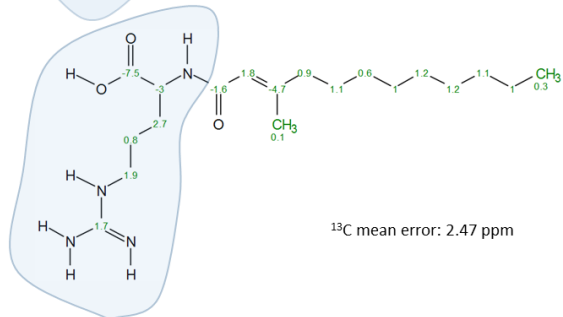
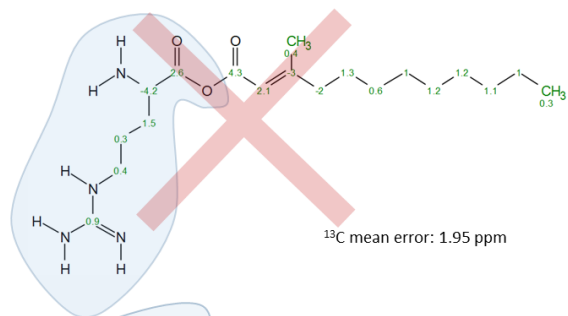
**Figure S14.**  $^{15}\text{N}$  HMBC (600 MHz,  $\text{CD}_3\text{OD}$ ) spectrum of Dendrobeaniamine A (**1**)



**Figure S15.**  $^{15}\text{N}$  prediction vs experimental shifts of Dendrobeaniamine A (**1**)



**Figure S16.**  $^{13}\text{C}$  prediction vs experimental shifts of potentially possible structures of Dendrobeaniamine A (**1**)



## Reference:

Hansen KO, Isaksson J, Bayer A, Johansen JA, Andersen JH, Hansen E. 2017. Securamine derivatives from the Arctic bryozoan *Securiflustra securifrons*. *J Nat Prod.* 80(12):3276-3283.

Michael P, Hansen KO, Isaksson J, Andersen JH, Hansen E. 2017. A novel brominated alkaloid securidine A, isolated from the marine bryozoan *Securiflustra securifrons*. *Molecules.* 22(7).

## Paper III

1 Article

## 2 **Antimicrobial Activity of Securamines from the** 3 **Bryozoan *Securiflustra securifrons***

4 **Kine Ø. Hansen**<sup>1,\*</sup>, **Ida K. Ø. Hansen**<sup>2</sup>, **Céline S. Richard**<sup>2</sup>, **Priyanka Michael**<sup>1</sup>, **Marte Jenssen**<sup>1</sup>,  
5 **Jeanette H. Andersen**<sup>1</sup> and **Espen H. Hansen**<sup>1</sup>

6 <sup>1</sup> Marbio, UiT–The Arctic University of Norway, Breivika, Tromsø N-9037, Norway; kine.o.hanssen@uit.no  
7 (K.Ø.H.); raja.p.siranjeevi@uit.no (P.M.); marte.jenssen@uit.no (M.J.); jeanette.h.andersen@uit.no (J.H.A.);  
8 espen.hansen@uit.no (E.H.H.);

9 <sup>2</sup> Norwegian College of Fishery Science, UiT - The Arctic University of Norway, Breivika, N-9037 Tromsø,  
10 Norway; ida.k.hansen@uit.no (I.K.Ø.H.); celine.s.richard@uit.no (C.S.R.)

11 \* Correspondence: kine.o.hanssen@uit.no (K.Ø.H.); Tel.: +47-77649272

12 Academic Editor: name

13 Received: Mai 2019; Accepted: 00.00.2019; Published: 00.00.2019

14 **Abstract:** One fraction from the organic extract of the Arctic marine bryozoan *Securiflustra securifrons*  
15 was found to be active against the human pathogenic bacterium *Streptococcus agalactiae* (gr. B).  
16 Chemical investigation of the fraction revealed that it contained several variants of the previously  
17 reported securamines and securidine A (6). The securamines are highly modified hexacyclic  
18 alkaloids sharing a common isoprene-histamine-tryptamine backbone. Compound 6 is a  
19 brominated tyrosine derivative. In this study, we describe the antimicrobial activities of securamine  
20 C, E and H – J (4, 5 and 1 – 3) and the attempt to deconvolute the mode of action of 1 using modified  
21 variants of *Bacillus subtilis* and *Escherichia coli*.

22 **Keywords:** Marine bryozoan; *Securiflustra securifrons*; the securamines; antimicrobial activity;  
23 marine bioprospecting

---

### 25 1. Introduction

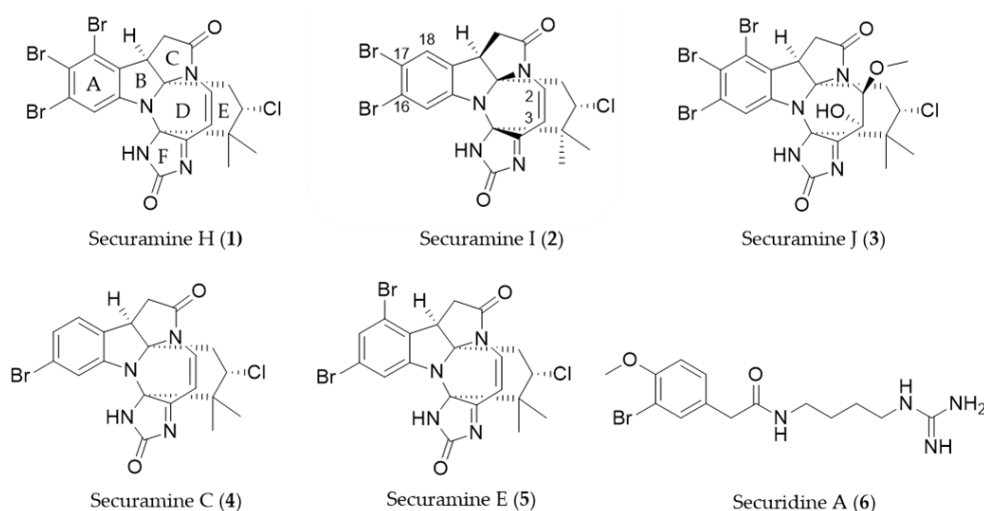
26 The increasing prevalence of antibiotic resistant bacteria is recognized as one of the most serious  
27 global threats to human health in the 21<sup>st</sup> century. Extensive use of antibiotics together with declining  
28 investments into discovery and development of new treatment options to combat pathogens have  
29 aggravated the problem [1, 2]. In the search for new antimicrobial agents, nature remains the richest  
30 and most versatile source [3, 4]. In fact, close to 80% of all marketed anti-infective agents originates  
31 from a natural source [5]. Bryozoans are a phylum of suspension-feeding mainly colonial  
32 invertebrates found in aquatic benthic ecosystems throughout the world [6]. They generally form  
33 sessile colonies of genetically identical, polymorphic units termed zooids [7, 8]. These colonies are  
34 extremely vulnerable to biofouling, predation by grazers and pathogenic attacks [9, 10]. As a result,  
35 bryozoan biomass has yielded several structurally diverse bioactive secondary metabolites. In  
36 general, little is known regarding the ecological role of bryozoan derived secondary metabolites.  
37 These compounds are attractive starting points for pharmaceutical development. The best known  
38 examples are the bryostatins, isolated from *Bugula neritina* (Linnaeus, 1758), some of which are under  
39 clinical development as an anticancer drug candidate for combination therapy [11] and neurological  
40 disorders [12–14]. In addition, several compounds with antimicrobial properties, including inhibition  
41 of Gram-negative (G-) and Gram-positive (G+) bacteria and quorum-sensing [15] and fungicidal  
42 properties [16], have been isolated. These include the flustramines, brominated tricyclic indole  
43 alkaloids isolated from *Flustra foliacea* (Linnaeus, 1758) [17, 18], the tribrominated indole  
44 terminoflustrindole A isolated from *Terminoflustra* (*Chartella*) *membranaceotruncata* (Smitt, 1868) [16,



19], the pterocellins isolated from *Pterocella vesiculosa* (Lamarck, 1816)[20] and the alternatamides isolated from *Amathia alternata* (Lamouroux, 1816)[21]

As part of our search for bioactive secondary metabolites from marine organisms we have previously prepared the aqueous and organic extracts of *Securiflustra securifrons* (Pallas, 1766) into eight fractions each using RP-flash chromatography and tested them for anticancer activity [22, 23]. Out of these, fraction five of the organic extract was found to be active against a human melanoma cancer cell line. The components in this fraction found to be responsible for the cytotoxicity were the hexacyclic alkaloids securamine C (4), E (5) and H – J (1 – 3) (Figure 1). The structures and cytotoxic properties of 1 - 5 have been reported by our group [22]. Furthermore, our group has reported the structure and bioactivity characterization of securidine A (6) (Figure 1), isolated from the aqueous extract [23].

In this study, fraction three of the organic extract of *S. securifrons* was found to be active against the pathogenic bacterium *Streptococcus agalactiae* (Gr. B). HRMS analysis of this fraction revealed the presence of securamines and 6. Compound 6 has been determined inactive against microorganisms [23]. The antibacterial properties of the securamines have however not been previously examined. This, coupled with the knowledge that nature has provided a wealth of promising lead structures for antibiotic development [24-26], motivated an investigation into the potential of the securamines as antibiotics. Compounds 1, 2 and 5 were found to inhibit the growth of G+ bacteria, out of which 1 was the most active with minimum inhibitory concentration (MIC) values as low as 3.13  $\mu$ M. Compound 1 was therefore selected for mode of action studies towards modified variants of the G+ bacterium *Bacillus subtilis* and the G- bacterium *E. coli*. While *E. coli* was not affected, these studies revealed that 1 did not affect *B. subtilis* viability by bacterial membrane integrity disruption at concentrations close to the MIC. Furthermore, 1 was found to reduce metabolic activity of *B. subtilis*, indicating that the compound affected *B. subtilis* viability by interacting with an intracellular target which is part of the metabolic machinery of the bacterium. Therefore, 1 was assayed in a mode of action screening against reporter gene based bacterial biosensors for its potential to interfere with DNA replication, transcription, translation, fatty acid- and folic acid synthesis. Our results did not indicate that any of these bacterial processes were affected by 1, although such activity could not be excluded, since the assay only detect a selected range of known activities in one model organism. Furthermore, 1 and 6 were assayed together against bacteria to evaluate whether their co-exposure produced synergistic effect against the assayed strains. Our study revealed no such effect. The effect of 1 on the metabolic activity of *B. subtilis* however demonstrates the potential of the compound as a starting point for the development of a new antibiotic.



79  
80

81 **Figure 1.** Structures of securamine C, E and H – J (4, 5 and 1 – 3) and securidine A (6), isolated from  
82 extracts of the Arctic marine bryozoan *Securiflustra securifrons*.

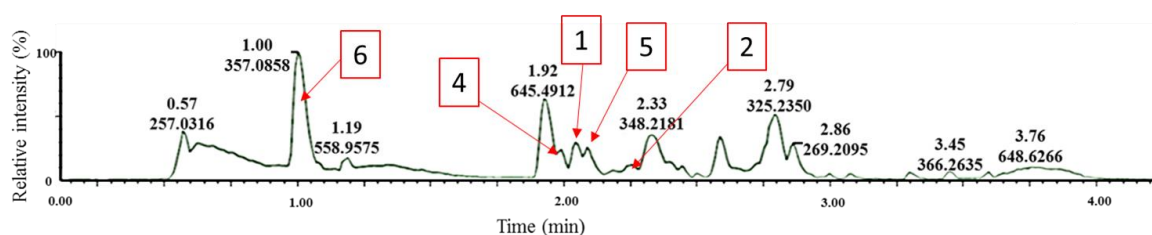
## 83 2. Results and discussion

### 84 2.1. Biomass, extraction, fractionation, compound isolation and structure elucidation

85 The biomass of *S. securifrons* was collected off the coast of Hjelmsøya, freeze dried and subjected  
86 to liquid-liquid extraction and fractionated using flash chromatography. Compounds 1 – 6 were  
87 isolated using mass guided semi-preparative HPLC and their structures elucidated using  
88 spectroscopic methods (HRMS, 1D- and 2D-MNR) as previously described [22, 23].

### 89 2.2. Antibacterial screening and chemical investigation of the flash fractions of *S. securifrons*

90 The flash fractions of the organic *S. securifrons* extract were assayed for activity against the  
91 pathogenic bacteria strains *S. aureus*, *E. faecalis*, *E. coli*, *P. aeruginosa* and *S. agalactiae* (Gr. B) at 250  
92 µg/mL. Flash fraction three (eluting at 50% MeOH) was found to be active against the G+ bacteria *S.*  
93 *agalactiae* (Gr. B). Fraction three was inactive against the remaining bacteria and the remaining  
94 fractions were inactive against all bacteria. Chemical analysis of the fraction using UHPLC-HRMS  
95 revealed that it contained compounds belonging to the securamine family, including compounds 1,  
96 2, 4 and 5. In addition, the brominated tyrosine derivative 6 was present in abundant amounts (Figure  
97 2). As 6 has previously been tested for antibacterial activity, resulting to be inactive [23], only the  
98 securamines were selected for antibacterial bioactivity testing.  
99



100

101 **Figure 2.** The base peak intensity chromatogram of flash fraction three of the organic extract of *S.*  
102 *securifrons* showed the presence of securidine A (6) and several securamines, including securamine H,  
103 I, C and E (1, 2, 4 and 5).

### 104 2.3. Antimicrobial activity of 1 - 5

105 The MIC of compounds 1 – 5 against four G+ and two G- bacteria strains, three yeast strains and  
106 towards the biofilm formation capability of *Staphylococcus epidermidis* were tested (Table 1).  
107 Compounds 1, 2 and 5 showed activity against all or most of the G+ strains. No activity was found  
108 towards the G- bacteria, the yeast strains or against biofilm formation at the highest assay  
109 concentration (50 µM). Compared to flash fraction three, the purified securamines show a wider  
110 range of antibacterial activity. The discrepancy in bioactivity between fraction three and the  
111 securamines can be explained by several phenomena. The fraction is a complex mixture of natural  
112 products, where the antibacterial securamines only constitute a small part. Thus, despite the  
113 relatively high assay concentration of 250 µg/mL, the purified compounds were most likely tested at  
114 lower concentrations when assayed as part of flash fraction three, compared to when they were  
115 assayed in their pure form. Moreover, securamine bioactivities may be masked by other sample  
116 components present in flash fraction three, which may affect their solubility or interact more potently  
117 with the securamines compared to their target on or in the bacteria [27]. Furthermore, 1 was found in  
118 abundant amounts in flash fraction five of the organic extract of *S. securifrons*. This fraction did not  
119 have antibacterial activity at 250 µg/mL, as previously described [22]. This difference can be  
120 explained by the same reasons as mentioned above.

121 Based on these results it appears that a double bond in the D-ring between C-2 and C-3 and more  
122 than one bromine on the A-ring at C-16, C-17 and/or C-18 are important for the antibacterial activity  
123 of the securamines. This observed structure activity relationship (SAR) correlates well with the  
124 previously reported SAR of the securamines against melanoma, lung and breast cancer cell lines [22],

125 where **1**, **2**, **4** and **5** inhibited cell viability. The lowest IC<sub>50</sub> value, 1.4 μM, was measured for **1** against  
 126 a human melanoma cell line. Compound **1** is brominated on C-16, C-17 and C-18 and have a double  
 127 bond between C-2 and C-3. This may further indicate that the activities of the securamines against  
 128 both bacteria and cancer cell lines are caused by an unspecific interaction with and disruption of  
 129 biological membrane integrity. This is however unlikely, as the herein assayed yeast strains were  
 130 unaffected by the securamines at the highest assayed concentration (50 μM), indicating an unrelated  
 131 intracellular target in the cancer cells and bacteria. Compound **1** showed the broadest and most  
 132 potent inhibition, with MIC values ranging from 3.13 – 6.25 μM against the G<sup>+</sup> bacteria, and was  
 133 therefore chosen for further investigation .

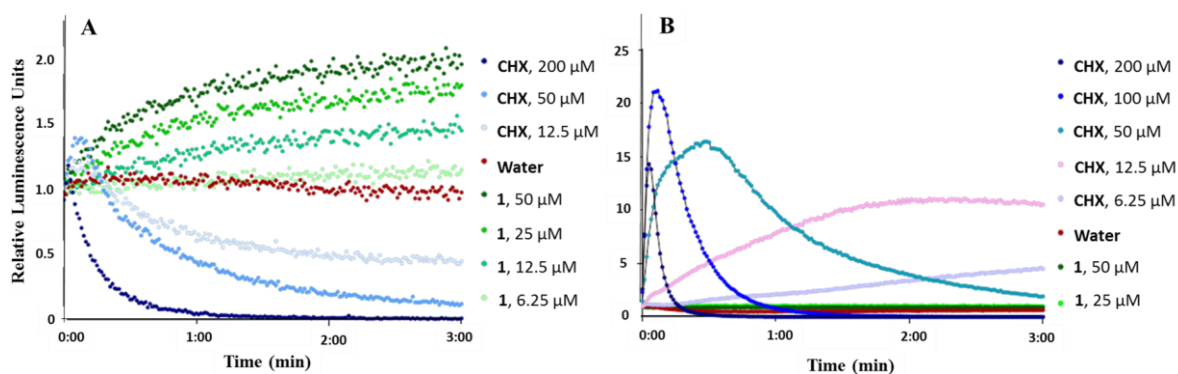
134 **Table 1.** MIC (μM) of securamine H-J, C and E (**1** – **5**) against four G<sup>+</sup> and two G<sup>-</sup> bacteria strains,  
 135 against *Staphylococcus epidermidis* biofilm formation and against three yeast strains.

Microorganisms	Minimum inhibitory concentration (μM)				
	1	2	3	4	5
G <sup>+</sup> bacteria:					
<i>Bacillus subtilis</i>	6.25	>50	>50	>50	>50
<i>Staphylococcus aureus</i>	3.13	12.5	>50	>50	25
<i>Enterococcus faecalis</i>	6.25	25	>50	>50	50
<i>Streptococcus agalactiae</i> (Gr. B)	6.25	25	>50	>50	25
G <sup>-</sup> bacteria:					
<i>Escherichia coli</i>	>50	>50	>50	>50	>50
<i>Pseudomonas aeruginosa</i>	>50	>50	>50	>50	>50
Biofilm formation					
<i>Staphylococcus epidermidis</i>	>50	>50	>50	>50	>50
Yeast					
<i>Candida albicans</i>	>50	>50	>50	>50	>50
<i>Rhodotorula sp.</i>	>50	>50	>50	>50	>50
<i>Aureobasidium pullulans</i>	>50	>50	>50	>50	>50

#### 136 2.4. Real-time measurement of membrane integrity of bacteria when exposed to **1**

137 *B. subtilis* and *E. coli*, carrying the pCSS962 plasmid with the LucGR gene, were used to assess  
 138 the membrane disruptive properties of **1**. The strains express eukaryotic luciferase and will emit  
 139 luminescence if its membrane is disrupted and D-luciferin from the growth medium is allowed to  
 140 diffuse into the cell [28]. If the bacteria cells die following membrane disruption, an initial rise in  
 141 relative luminescence units (RLU) caused by D-luciferin influx, will be followed by declining RLU  
 142 values as bacterial ATP reserves are exhausted and the enzymatic reaction consequently stopped.  
 143 The luminescence measurements of *B. subtilis* and *E. coli* after exposure to ranging concentrations of  
 144 **1** or chlorhexidine (CHX, positive control), an antibiotic known for its cell wall and membrane-  
 145 disruptive activities [29], can be seen in Figure 3. CHX treated *B. subtilis* gave an initial increase  
 146 followed by a decrease in RLU values. In contrast to this, **1** caused a persistent increase in light  
 147 emission from the cells within the 3 min assay time at the three highest concentrations tested (12.5,  
 148 25 and 50 μM; **2**, **4** and **8** x the MIC value of 6.25 μM, respectively). This increase were most likely  
 149 caused by an increased D-luciferin influx into the cells caused by effects on the membrane. This effect  
 150 does however not appear to affect the viability of *B. subtilis*, as the ATP reserves in the bacteria are  
 151 not exhausted and resultantly no delayed drop in RLU was observed, indicating that the effect of **1**  
 152 was different from that of CHX. The lack of a drop in ATP reserves following *B. subtilis* exposure to  
 153 **1** furthermore indicates that **1** is bacteriostatic rather than bactericidal at the highest assayed  
 154 concentrations. At 6.25 μM (and at lower concentrations, data not shown) **1** did not cause an influx  
 155 of D-luciferin, as relative light emission remained equal to the water control. In contrast to CHX, no  
 156 substantially increase in D-luciferin uptake and thus no affect plasma membrane integrity of *E. coli*  
 157 could be detected for **1**, even at the highest assayed concentrations (Figure 3B).

158



159

160

161 **Figure 3.** Kinetics of the relative luminescence emission by **A)** *B. subtilis* (pCSS962) and **B)** *E. coli*  
 162 (pCSS962) treated with ranging concentrations of securamine H (**1**) or chlorhexidine (**CHX**) (in green  
 163 and blue colors, respectively). Each point is the mean of three independent measurements. CHX and  
 water (red color) were used as positive and negative controls, respectively.

164

### 2.5. Assessment of membrane potential of bacteria when exposed to **1**

165

166

167

168

169

170

171

172

173

174

175

176

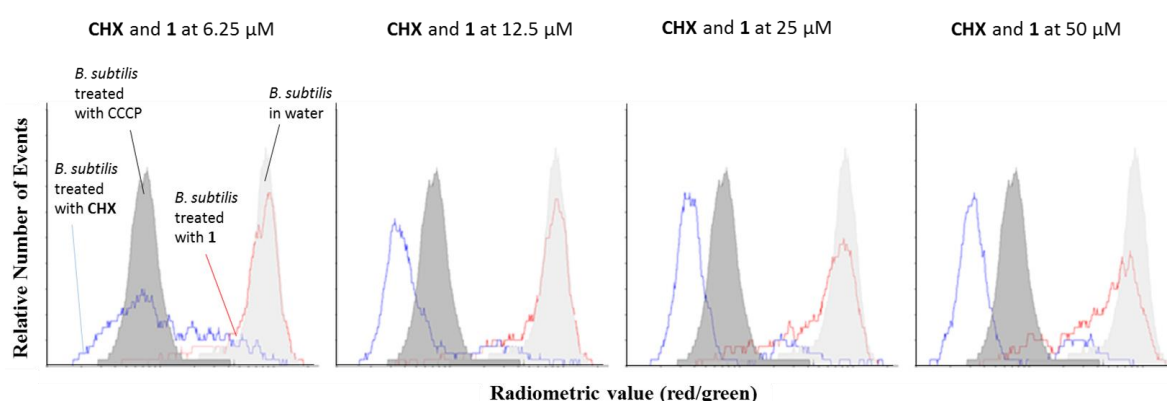
177

178

179

180

To further elucidate if **1** affected the membrane integrity of *B. subtilis* directly, the membrane potential of *B. subtilis* was measured after 3 min exposure to ranging concentrations of **1**. Bacterial cells were stained with a membrane potential sensitive dye and subsequently analyzed by flow cytometry. The assay is based on the use of 3,3'-diethylcarbocyanine iodide (DiOC<sub>2</sub>(3)), whose fluorescence shifts from green to red in response to higher cytosolic concentrations in cells with active membrane potential where the dye aggregates. Ratiometric analysis of green to red fluorescence allows for estimating changes in membrane potential of bacteria [30]. CHX and carbonyl cyanide m-chlorophenylhydrazone (CCCP) were used as positive and negative controls, respectively. CCCP blocks the generation of the electrochemical proton gradient, and thus lowers the membrane potential in bacteria [31]. Increasing concentrations of CHX decreased the ratio of red/green, showing that a higher CHX concentrations result in higher fraction of bacteria with disrupted membranes. For **1**, increased concentrations resulted in a decreased red/green ratio, however this decrease was significantly less marked compared to the CCCP and CHX controls. At the observed MIC (6.25 μM), only a slight shift were visible, further indicating that the activity of **1** were not due to direct membrane integrity disruption (Figure 4).



181

182

183

184

185

186

187

188

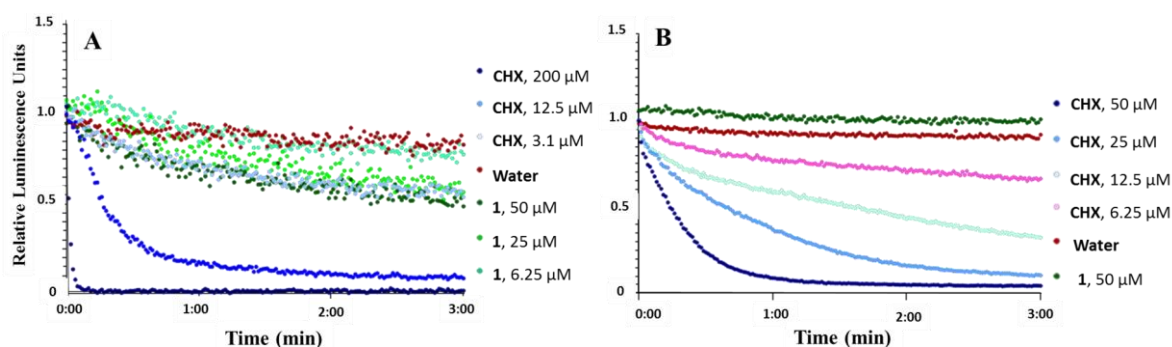
189

**Figure 4.** The effect of securamine H (**1**) in comparison to chlorhexidine (**CHX**) on the membrane potential of *B. subtilis*. The bacteria were treated for 3 min with ranging concentrations of **1** or **CHX** and subsequently incubated for at least 30 min with 30 μM DiSO<sub>2</sub>(3). The overlaid histograms show the positive and the negative controls treated with 5 μM carbonyl cyanide m-chlorophenylhydrazone (CCCP) (shaded dark grey) and water (shaded light grey), respectively. Measurements depicting analysis of **1** are shown as red lines and **CHX** as blue lines. The radiometric values (red/green) are depicted on the x axis, the relative number of events on the y axis.

190 2.6. Effect of **1** on cell viability measured in real-time

191 *B. subtilis* carrying a chromosomal integration of a *luxABCDE* [32] operon and *E. coli* carrying  
 192 the pCGLS-11 [33] plasmid with a *Photorhabdus luminescens* *lux* operon (*luxCDABE*) were used to  
 193 assess the effect of **1** on bacterial cell viability measured in real-time. From these operons the strains  
 194 express a bacterial luciferase and fatty acid reductases for regeneration of long-chain fatty aldehydes,  
 195 which serve as substrates for light production. Light production is therefore linked to several  
 196 metabolic processes, which in turn depend on the regeneration of reduction equivalents and ATP [34,  
 197 35]. While light production indicates active metabolism, loss of light production indicates a decrease  
 198 in metabolic activity, and hence, reduced viability of the cells. The measured luminescence of *B.*  
 199 *subtilis* and *E. coli* after addition ranging concentrations of **1** or CHX can be seen in Figure 5. At  
 200 concentrations above the MIC (6.25  $\mu$ M) **1** affected the viability of *B. subtilis* within the 3 min assay  
 201 time (Figure 5A). Indeed, **1** at a concentration of 50  $\mu$ M affected cell viability of the strain at a similar  
 202 level as CHX at 3.1  $\mu$ M, resulting in a decrease of around 40% of relative luminescence units after 3  
 203 min. The decrease in light emission within 3 min at concentrations above the MIC confirmed that cell  
 204 viability was affected relatively fast. However, even at concentrations above the MIC viability does  
 205 not drop below 50%, which was the case for CHX. In addition, the ATP dependent membrane assay  
 206 showed elevated light emission at these concentrations indicating that ATP levels are not the limiting  
 207 factor. No effect was observed towards *E. coli* (Figure 5B).

208  
 209



210

211 **Figure 5.** Kinetics of the relative luminescence emission by **A)** *B. subtilis* (pCGLS-11) and **B)** *E. coli*  
 212 (pCGLS-11) treated with ranging concentrations of securamine H (**1**) or chlorhexidine (CHX). Each  
 213 point is the mean of three independent measurements.

214 In summary, the results from the membrane integrity and metabolic activity assays show an  
 215 influx of D-luciferin at concentrations higher than the MIC, no effect on membrane potential and  
 216 reduction of metabolic activity in *B. subtilis* exposed to **1**. The effect of **1** on *B. subtilis* viability is thus  
 217 most likely not caused by direct effects on the cell membrane, but rather by interference with one or  
 218 more metabolic processes in *B. subtilis*.

219 2.7. Investigation of possible intracellular targets of **1** typical for conventional antibiotics

220 In an attempt to gather further information about the mode of action of **1**, the compound was  
 221 tested against a panel of six biosensors responding to interference with some major metabolic  
 222 pathways in *B. subtilis*. Compound **1** was tested for interference with DNA replication, transcription,  
 223 translation as well as interference with fatty acid, cell wall and folic acid synthesis. Antibiotics of the  
 224 respective modes of action, as shown in Table 3, served as positive controls. None of the strains used  
 225 reacted to coincubation with **1** at the assayed concentrations during the 8 h the assay was run (twofold  
 226 dilution series between 50 and 0.39  $\mu$ M). The purpose of the sensors is to detect similar activity, but  
 227 negative results do not exclude a given mode of action. While for example erythromycin efficiently  
 228 induces the sensor for translation interference, kanamycin does not [36]. Similarly, the cell envelope  
 229 stress sensor, which is based on the *liaI* promoter and the *liaRS* two component system, is most  
 230 sensitive when challenged with antibiotics affecting the lipidII cycle, as is the case for bacitracin or

231 vancomycin, while they remain uninduced by penicillin [37]. This hampers the interpretation of the  
 232 results since all the assays for the activity of **1** were negative. However, **1** seems not to belong to the  
 233 subgroups of antibiotic mode of actions the sensors recognize. Interestingly, the *liaI* based cell  
 234 envelope stress sensor is known to respond to membrane active compounds such as Nisin [37].  
 235 Therefore the negative response to **1** was in accordance with the earlier results indicating a different  
 236 mode of action than interference with membrane integrity.

237 **Table 3.** List of sensor strains with the promoter region fused to the *luxABCDE* operon located in the  
 238 *sacA* region of the *B. subtilis* 168 chromosome. Assays were started with bacteria at mid log phase  
 239 diluted to approximately  $10^7$  bacteria. The respective positive control antibiotics used are shown in  
 240 the last column.

Strain number	Target	Promoter	Control antibiotic
EM10	DNA replication	<i>yorB</i>	Ciprofloxacin
EM11	Transcription	<i>helD</i>	Rifampicin
EM12	Translation	<i>yheI</i>	Erythromycin
HMB67	Cell envelope	<i>liaI</i>	Vancomycin
HMB69	Fatty acid synthesis	<i>fabHB</i>	Irgasan
HMB70	Folic acid synthesis	<i>panB</i>	Trimethoprim
HMB62	Constitutive control	<i>veg</i>	-

### 241 2.8. Synergistic antibacterial effects of **1** and **6**

242 When tested alone, **6** was found to not be active against bacteria and biofilm formation at 100  
 243  $\mu\text{M}$  [23]. To evaluate whether a combination of compounds from fraction three of the organic extract  
 244 of *S. securifrons* could potentiate each other's antibacterial activity, **1** and **6** were assayed as a mixture  
 245 at ranging concentrations arranged in a checkerboard titration (assay concentrations of both  
 246 compounds: 50 to 1.56  $\mu\text{M}$ , **6** concentration points, 2 fold dilution). Compound **6** was chosen to be  
 247 tested together with **1** over the other securamine variants as the securamines are present together in  
 248 substantially higher concentrations in flash fractions four, five and six of the organic extract of *S.*  
 249 *securifrons*, and these fractions were not active in the antibacterial screening. This indicates that a  
 250 mixture of securamines does not potentiate each other's antibacterial activities in these specific  
 251 fractions. The combination of **6** and the securamines however only occurs in fraction three or the  
 252 organic extract of *S. securifrons*. The various mixtures of **1** and **6** were tested for synergistic activity  
 253 against *S. aureus*, *E. faecalis*, *E. coli*, *P. aeruginosa* and *S. agalactiae* (Gr. B). The G- strains were not  
 254 affected by the mixture. The MIC values of **1** against the G+ strains in a mixture with **6** were identical  
 255 to those measured for **1** alone (Table 1: *S. aureus*: 3.13  $\mu\text{M}$ , *E. faecalis*: 6.25  $\mu\text{M}$ , *S. agalactiae* (Gr. B): 6.25  
 256  $\mu\text{M}$ ). The ecological function and bioactivity of **6** thus still remains to be determined.

## 257 3. Experimental section

### 258 3.1. Animal material, extraction, fractionation, compound isolation and structure elucidation

259 Specimens of *S. securifrons* were collected off the coast of Hjelmsøya, Norway in 2014 using an  
 260 Agassi's dredge trawl at 72 m depth. The specimens were prepared into an organic extract, which  
 261 was further fractionated into eight fractions using RP-flash chromatography and tested for  
 262 bioactivity. The compounds were isolated using mass-guided semi-preparative HPLC and their  
 263 structure elucidated using spectroscopic methods (HRMS, 1D- and 2D-NMR), all as previously  
 264 described in detail [22, 23].

265

### 266 3.2. Microorganism strains, growth media and assay temperature

267 *Enterococcus faecalis* (ATCC: 29212) and *Streptococcus agalactiae* (Gr. B) (ATCC: 12386) were grown  
268 and assayed in brain-heart infusion broth (BHI; Oxoid, Hampshire, England). *Staphylococcus aureus*  
269 (ATCC: 25923), *Escherichia coli* (ATCC: 25922), *Pseudomonas aeruginosa* (ATCC: 27853) and *Bacillus*  
270 *subtilis* (ATCC: 23857) and its derivatives were grown on Mueller Hinton Broth (MH; Merck,  
271 Darmstad, Germany). *Staphylococcus epidermidis* (ATCC: 35984) was grown and assayed in tryptic soy  
272 broth (TS; Merck, Darmstadt, Germany). All bacteria were grown and assayed at 37 °C. The yeast  
273 strains *Candida albicans* (ATCC: 10231) and *Rhodotorula* sp. and the *Aureobasidium pollulans* mold  
274 (*Rhodotorula* sp and *A. pollulans* were obtained from Professor Arne Tronsmo, The Norwegian College  
275 of Life Sciences, Ås, Norway), were cultivated on potato dextrose (PD) agar (Difco, Detroit, MI, USA)  
276 with 2% D(+)-glucose (Merck, Darmstad, Germany) at room temperature.

### 277 3.3. Antimicrobial and anti biofilm formation assays

#### 278 3.3.1. Antibacterial assay

279 MIC values of **1 – 5** were determined using the broth microdilution method, as previously  
280 described [23]. Briefly, suspended bacteria in log phase were added to 96-well microtiterplates at a  
281 concentration of 1.500 – 15.000 colony forming units/mL. Serial dilutions of **1 – 5** were subsequently  
282 added and left to inoculate for 24 h before growth inhibition was measured using a Victor multilabel  
283 counter (PerkinElmer, Singapore) at 600 nm. Growth medium diluted with water (1:1) was used as  
284 negative control and bacteria suspension diluted with water (1:1) as positive control. For *B. subtilis*,  
285 oxytetracycline was used as positive assay control, for the remaining strains, gentamycin was used.  
286 The assays were repeated three times.

#### 287 3.3.2. Inhibition of biofilm formation

288 *S. epidermidis* was used to assess the effect of **1 – 5** on biofilm formation. An overnight culture of  
289 *S. epidermidis* was diluted with fresh TS broth with 1% glucose (1:100), transferred to the wells of 96-  
290 well microtiter plates and added ranging concentrations (assay cons: 50 – 0.39 µM) of **1 – 5**. After  
291 overnight incubation, the bacteria suspension was carefully discarded, the biofilm fixed by  
292 incubation at 55 °C for 1h and stained by 0.1% crystal violet for 5 min before being washed away with  
293 water. The plates were once more left to dry at 55 °C for 1h before 70 µL 70% ethanol was added to  
294 each well and the plates left to incubate for 10 min before biofilm formation was observed by visual  
295 inspection of the plates. The MIC was defined as the lowest concentration where no biofilm formation  
296 was visible. *S. epidermidis* suspension, diluted with 50 µL of water, was used as a positive control, and  
297 50 µL *Staphylococcus haemolyticus* suspension with 50 µL of water as negative control. A mixture of 50  
298 µL water and 50 µL TS broth was used as assay control.

#### 299 3.3.3. Antifungal assay

300 Fungal spores of yeast strains *Candida albicans* and *Rhodotorula* sp. and the *A. pollulans* mold,  
301 were dissolved in PD broth and the cell concentration was determined and adjusted after counting  
302 in a Bürker chamber. A final fungal spore concentration of  $2 \times 10^5$  spores/mL were inoculated in 96-  
303 well nunc microtiter plates (100 µL total well volume) along with ranging concentrations of **1 – 5** (50  
304 – 0.78 µM). The assay plates were incubated in room temperature for 24 h (*C. albicans*) and 48 h (*A.*  
305 *pollulans* and *Rhodotorula* sp.). Ranging concentrations of amphotericin-B was used as positive control  
306 (32 - 0.25 µg/mL), and water as a negative (growth) control. After incubation the OD value (600 nm)  
307 was measured in a Synergy H1 Hybrid Reader (BioTek, Winooski, VT, USA). MIC values of **1 – 5**  
308 were defined as the lowest concentration of the compounds that showed >90% inhibition compared  
309 to the negative growth control (as measured by OD). The assays were repeated three times.

310

### 311 3.4. Mode of action studies

#### 312 3.4.1. Real-time membrane integrity assay measuring immediate membrane disruption

313 The real-time membrane integrity assay was performed using *B. subtilis* 168 and *E. coli* K12  
314 (MC1061), both carrying the plasmid pCSS962 with the eukaryotic luciferase gene *lucGR*. Luciferase  
315 is dependent on D-luciferin as substrate to emit light, a substrate that does not penetrate intact cell  
316 membranes. The assay is a modification of a previously described protocol [28]. *B. subtilis* and *E. coli*  
317 were cultured overnight in MH broth with 5 µg/mL chloramphenicol (Merck KGaA, Darmstad,  
318 Germany) and a mixture of 20 µg/mL chloramphenicol/100µg/mL ampicillin, respectively, before  
319 being centrifuged at 4500 rpm for 10 min. The supernatant was removed and the pellet resuspended  
320 in MH broth to give an OD<sub>600</sub> of 0.1. D-luciferin potassium salt (assay concentration: 1 mM) was added  
321 and background luminescence measured. Ranging concentrations of **1** (assay concentrations: 50 –  
322 0.78 µM) dissolved in water were added to black round-bottom 96-well microtiterplates (Nunc,  
323 Roskilde, Denmark) as well as a ranging concentrations of the control, CHX acetate (assay  
324 concentrations 50 µM – 1.6 µM). The plates were placed in a Synergy H1 Hybrid Reader (BioTek,  
325 Winooski, VT, USA). Aliquots (90 µL, to give a total assay volume of 100 µL) of the prepared bacteria  
326 suspension was added to the test wells by an automatic injector with tracking of the luminescence  
327 emission every second for 180 s. Three independent measurements were conducted.

#### 328 3.4.2. Membrane potential assay

329 To analyse the effects of **1** on the membrane potential of *Bacillus subtilis* 168, the BacLight  
330 bacterial membrane potential kit (Invitrogen) was used. The assays were performed in 96 well 1.8 ml  
331 deepwell-plates (Corning) and analyzed by a Cube8 flowcytometer with an autosampler (Sysmex).  
332 The assay is based on the dye DiOC<sub>2</sub>(3), which causes green fluorescens in all bacterial cells. The  
333 fluorescence shifts to red when the dye molecules self associate due to their accumulation in the  
334 cytoplasm of viable bacteria with intact membrane potential [30]. Differences in fluorescence  
335 emission were detected by flowcytometry. The ratiometric values of red/green fluorescence were  
336 used to analyze if the proton gradient of the tested cells were affected or not. The experiment was  
337 performed according to the manufacturers suggestions but adapted to the 96 well format and  
338 therefore conducted with reduced volumes. Briefly, 5 µl 3mM DiOC<sub>2</sub>(3) solution was added to 500  
339 µl cell suspension, which contained approximately 10<sup>6</sup> bacteria and had been pretreated for 3 min  
340 with different concentrations of the respective analytes. Before starting the measurement the samples  
341 were incubated in the dark for 30 min at RT. The samples were then measured in the Cube8 and  
342 analyzed with excitation by the blue laser (488 nm) and forwards scatter (FSC), side scatter (SSC), FL1  
343 (emission 536/40 nm) and FL3 (emission 675/20 nm). Data analysis was performed by the freely  
344 available flowing software using the first 2000 events of the bacterial population in each measurement  
345 for ratiometric analysis (flowingsoftware.btk.fi).

#### 346 3.4.3. Real-time cell viability assay

347 The real-time cell viability assay was performed using *B. subtilis* 168 (ATCC: 23857) and *E. coli*  
348 K12 (ATCC: MC1061) carrying a chromosomal integration of the luxABCDE operon or the plasmid  
349 pCGLS-11 with the lux operon luxCDABE, respectively. The assay is a modification of a previously  
350 described protocol [38]. *B. subtilis* and *E. coli* were cultured overnight in MH broth with 5 µg/mL  
351 chloramphenicol (Merck KGaA, Darmstad, Germany) and 100 µg/mL ampicillin, respectively, before  
352 being centrifuged at 4500 rpm for 10 min. The supernatant was removed and the pellet resuspended  
353 in MH broth to give an OD<sub>600</sub> of 0.1. Ranging concentrations of **1** (assay concentrations: 50 – 0.78 µM)  
354 dissolved in water were added to black round-bottom 96-well microtiterplates (Nunc, Roskilde,  
355 Denmark) as well as a ranging concentrations of the control, CHX acetate (assay concentrations 50  
356 µM – 1,6 µM). The plates were placed in a Synergy H1 Hybrid Reader (BioTek, Winooski, VT, USA).  
357 Aliquots (90 µL, to give a total assay volume of 100 µL) of the prepared bacteria suspension was



358 added to the test wells by an automatic injector with tracking of the luminescence emission every  
359 second for 180 s. Three independent measurements were performed.

#### 360 3.4.4. Promotor activity based whole-cell biosensor assay

361 Whole cell mode of action specific biosensors were used to determine if the activity of **1**  
362 correlates with some previously known modes of actions. The biosensors were generated by cloning  
363 promoter fusions to *luxABCDE* in the plasmid pBS3*Clux* and subsequent recombination into the *sacA*  
364 site on the *B. subtilis* chromosome as described [32]. Interference with DNA replication, transcription,  
365 translation and fatty acid synthesis was tested by *B. subtilis* strains containing *luxABCDE* fusions to  
366 the promoters of the genes *yorB*, *helD*, *yheI* and *fabHB* respectively, as described for the firefly  
367 luciferase as reported [36]. Inhibition of cell wall synthesis was tested by a bacitracin inducible  
368 promoter construct described [32] based on the promoter of *liaI* fused to *luxABCDE*. The *veg* promoter  
369 fusion described in the same paper was used as a luminescence control. In addition a *panB-luxABCDE*  
370 promoter fusion described as a *lacZ*-fusion in patent US20020164602A1 [39] was used to test for  
371 inhibition of folic acid synthesis (details in Table 3). Compound **1** was tested in a two-fold dilution  
372 series starting with two  $\times$  *B. subtilis* MIC (MIC = 6.25  $\mu$ M). The respective control antibiotics were set  
373 up similar to the tested compound. The experiments were run at room temperature. Otherwise  
374 identical setup to the antimicrobial assay protocol (section 3.3.1) was used with additional  
375 measurement of luminescence every 15 min for 8 h. Peak luminescence of the controls was compared  
376 to luminescence of cells treated with **1**.

#### 377 3.5. Synergistic effects of **1** and **6**

378 The ability of **6** to lower the MIC values of **1** against *S. aureus*, *E. faecalis*, *E. coli*, *P. aeruginosa* and  
379 *S. agalactiae* (Gr. B) was tested using the same setup as described in chapter 3.3.1. (Antibacterial assay).  
380 Mixtures of **1** and **6** were prepared using a checkerboard titration setup. Both compounds were  
381 prepared at ranging concentrations resulting in assay concentrations of 50, 25, 12.5, 6.25, 3.13 and 1.56  
382  $\mu$ M of each compound. The finished plate with the dilution is illustrated in Figure 6.  
383

		Compound <b>6</b> ( $\mu$ M)							
		100	50	25	12.5	6.25	3.13		
100 $\mu$ M <b>1</b> , 100 $\mu$ M <b>6</b>								100	Compound <b>1</b> ( $\mu$ M)
50 $\mu$ M <b>1</b> , 100 $\mu$ M <b>6</b>								50	
and so on...								25	
								12.5	
								6.25	
							3.13 $\mu$ M <b>1</b> , 3.13 $\mu$ M <b>6</b>	3.13	

384

385 **Figure 6.** Layout of the mixtures of securamine H (**1**) and securidine A (**6**) in the compounds plate  
386 prepared to measure if a mixture of **1** and **6** would result in lower MIC values than **6** alone. The  
387 dilution were diluted 1:1 in the assay plate. .

#### 388 4. Conclusions

389 Securamine H (**1**) was found inhibit the viability of G+ bacteria and to reduce metabolic activity  
390 in *B. subtilis*. The effect was shown not to be caused by interference with DNA replication,  
391 transcription or translation, nor by interference with fatty acid, cell wall and folic acid synthesis and  
392 could not be explained by disruption of the cell membrane. The mode of action of **1** thus remains to  
393 be deconvoluted. However, as the result indicates that **1** has an intracellular target, the compound  
394 serves as an interesting starting point further investigations. The herein presented results  
395 demonstrate that marine bryozoans can be used as a source of compounds with antibacterial activity.

396 **Acknowledgments:** The authors are grateful for the help received by Dr. Hans-Matti Blencke in the mode of  
397 action studies and the preparation of this manuscript. We are grateful to Marbank for collecting the specimens  
398 of *S. securifrons* and to R. Johansen for taxonomic identification of the bryozoan.

399 **Author Contributions:** K.Ø.H. isolated the compounds; I.K.Ø.H., C.S.R., M.J. and K.Ø.H. conducted the  
400 bioactivity studies; K.Ø.H., I.K.Ø.H., J.H.A and E.H.H. designed the study; K.Ø.H, I.K.Ø.H. C.S.R., J.H.A. and  
401 E.H.H. prepared the manuscript.

402 **Conflicts of Interest:** The authors declare no conflict of interest.

## 403 References

- 404 1. Medernach, R. L.; Logan, L. K., The growing threat of antibiotic resistance in  
405 children. *Infect. Dis. Clin. North. Am.* **2018**, *32*, (1), 1-17.
- 406 2. National Academies of Sciences, E.; Medicine; Health; Medicine, D.; Board on  
407 Global, H.; Forum on Microbial, T., Combating antimicrobial resistance: A one  
408 health approach to a global threat: Proceedings of a workshop. *National Academies*  
409 *Press (US)*. **2017**.
- 410 3. Newman, D. J.; Cragg, G. M., Natural products as sources of new drugs from 1981  
411 to 2014. *J. Nat. Prod.* **2016**, *79*, (3), 629-661.
- 412 4. Genilloud, O., The re-emerging role of microbial natural products in antibiotic  
413 discovery. *Anton. Leeuw. Int. J. G.* **2014**, *106*, (1), 173-188.
- 414 5. Newman, D. J.; Cragg, G. M.; Snader, K. M., Natural products as sources of new  
415 drugs over the period 1981–2002. *J. Nat. Prod.* **2003**, *66*, (7), 1022-1037.
- 416 6. McKinney, F. K.; Jackson, J. B. C., Bryozoan evolution. *University of Chicago Press*  
417 **1991**, *1*, (1), 1-252.
- 418 7. Simpson, C.; Jackson, J. B. C.; Herrera-Cubilla, A., Evolutionary Determinants of  
419 Morphological Polymorphism in Colonial Animals. *The American naturalist* **2017**,  
420 *190*, (1), 17-28.
- 421 8. Kutyumov, V. A.; Maltseva, A. L.; Kotenko, O. N.; Ostrovsky, A. N., Functional  
422 differentiation in bryozoan colonies: a proteomic analysis. *Cell. Tissue Biol.* **2016**,  
423 *10*, (2), 152-159.
- 424 9. Figuerola, B.; Angulo-Preckler, C.; Núñez-Pons, L.; Moles, J.; Sala-Comorera, L.;  
425 García-Aljaro, C.; Blanch, A. R.; Avila, C., Experimental evidence of chemical  
426 defence mechanisms in Antarctic bryozoans. *Mar. Environ. Res.* **2017**, *129*, 68-75.
- 427 10. Gray, C. A.; McQuaid, C. D.; Davies-Coleman, M. T., A symbiotic shell-encrusting  
428 bryozoan provides subtidal whelks with chemical defence against rock lobsters. *Afr.*  
429 *J. Mar. Sci.* **2005**, *27*, (3), 549-556.
- 430 11. Newman, D. J.; Cragg, G. M., Marine natural products and related compounds in  
431 clinical and advanced preclinical trials. *J. Nat. Prod.* **2004**, *67*, (8), 1216-1238.
- 432 12. Kornberg, M. D.; Smith, M. D.; Shirazi, H. A.; Calabresi, P. A.; Snyder, S. H.; Kim,  
433 P. M., Bryostatin-1 alleviates experimental multiple sclerosis. *Proc. Natl. Acad. Sci.*  
434 *USA* **2018**, *115*, (9), 2186-2191.
- 435 13. Nelson, T. J.; Sun, M. K.; Lim, C.; Sen, A.; Khan, T.; Chirila, F. V.; Alkon, D. L.,  
436 Bryostatin effects on cognitive function and PKCvarepsilon in Alzheimer's disease  
437 Phase IIa and expanded access trials. *J. Alzheimers Dis.* **2017**, *58*, (2), 521-535.
- 438 14. Kollár, P.; Rajchard, J.; Balounová, Z.; Pazourek, J., Marine natural products:  
439 Bryostatins in preclinical and clinical studies. *Pharm. Biol.* **2014**, *52*, (2), 237-242.

- 440 15. Peters, L.; Konig, G. M.; Wright, A. D.; Pukall, R.; Stackebrandt, E.; Eberl, L.;  
441 Riedel, K., Secondary metabolites of *Flustra foliacea* and their influence on bacteria.  
442 *Appl. Environ. Microbiol.* **2003**, 69, (6), 3469-3475.
- 443 16. Maltseva, A. L.; Kotenko, O. N.; Kutyumov, V. A.; Matvienko, D. A.; Shavarda, A.  
444 L.; Winson, M. K.; Ostrovsky, A. N., Novel brominated metabolites from Bryozoa:  
445 a functional analysis. *Nat. Prod. Res.* **2017**, 31, (16), 1840-1848.
- 446 17. Adla, S. K.; Sasse, F.; Kelter, G.; Fiebig, H. H.; Lindel, T., Doubly prenylated  
447 tryptamines: cytotoxicity, antimicrobial activity and cyclisation to the marine natural  
448 product flustramine A. *Org. Biomol. Chem.* **2013**, 11, (36), 6119-6130.
- 449 18. Laycock, M. V.; Wright, J. L. C.; Findlay, J. A.; Patil, A. D., New physostigmine  
450 related bromoalkaloids from the marine bryozoan *Flustra foliacea*. *Can. J. Chem.*  
451 **1986**, 64, (7), 1262-1266.
- 452 19. Maltseva, A.; Kotenko, O.; Shabalin, K.; Shavarda, A.; Winson, M.; Ostrovsky, A.  
453 N., Novel brominated fungicidal alkaloid isolated from the marine bryozoan  
454 *Chartella membranacea truncata*. **2014**, 94, 163-168.
- 455 20. Prinsep, M. R., Further pterocellins from the New Zealand marine bryozoan  
456 *Pterocella vesiculosa*. *J. Nat. Prod.* **2008**, 71, (1), 134-136.
- 457 21. Lee, N. K.; Fenical, W.; Lindquist, N., Alternatamides A-D: new bromotryptamine  
458 peptide antibiotics from the Atlantic marine bryozoan *Amathia alternata*. *J. Nat.*  
459 *Prod.* **1997**, 60, (7), 697-699.
- 460 22. Hansen, K. O.; Isaksson, J.; Bayer, A.; Johansen, J. A.; Andersen, J. H.; Hansen, E.,  
461 Securamine Derivatives from the Arctic Bryozoan *Securiflustra securifrons*. *J. Nat.*  
462 *Prod.* **2017**, 80, (12), 3276-3283.
- 463 23. Michael, P.; Hansen, K. O.; Isaksson, J.; Andersen, J. H.; Hansen, E., A novel  
464 brominated alkaloid securidine A, isolated from the marine Bryozoan *Securiflustra*  
465 *securifrons*. *Molecules.* **2017**, 22, (7), 1236.
- 466 24. Clardy, J.; Fischbach, M. A.; Currie, C. R., The natural history of antibiotics. *Curr.*  
467 *biol.* **2009**, 19, (11), 437-441.
- 468 25. Fair, R. J.; Tor, Y., Antibiotics and bacterial resistance in the 21st century. *Perspect.*  
469 *Medic. Chem.* **2014**, 6, (6), 25-64.
- 470 26. Wencewicz, T. A., New antibiotics from Nature's chemical inventory. *Bioorgan.*  
471 *Med. Chem.* **2016**, 24, (24), 6227-6252.
- 472 27. Henrich, C. J.; Beutler, J. A., Matching the power of high throughput screening to the  
473 chemical diversity of natural products. *Nat. Prod. Rep.* **2013**, 30, (10), 1284-1298.
- 474 28. Virta, M.; Akerman, K. E.; Saviranta, P.; Oker-Blom, C.; Karp, M. T., Real-time  
475 measurement of cell permeabilization with low-molecular-weight membranolytic  
476 agents. *J. Antimicrob. Chemother.* **1995**, 36, (2), 303-15.
- 477 29. Kuyyakanond, T.; Quesnel, L. B., The mechanism of action of chlorhexidine. *FEMS*  
478 *Microbiol. Lett.* **1992**, 100, (1-3), 211-5.
- 479 30. Novo, D.; Perlmutter, N. G.; Hunt, R. H.; Shapiro, H. M., Accurate flow cytometric  
480 membrane potential measurement in bacteria using diethyloxycarbocyanine and a  
481 ratiometric technique. *Cytometry* **1999**, 35, (1), 55-63.

- 482 31. Kasianowicz, J.; Benz, R.; McLaughlin, S., The kinetic mechanism by which CCCP  
483 (carbonyl cyanidem-chlorophenylhydrazone) transports protons across membranes.  
484 *J. Membr. Biol.* **1984**, 82, (2), 179-190.
- 485 32. Radeck, J.; Kraft, K.; Bartels, J.; Cikovic, T.; Dürr, F.; Emenegger, J.; Kelterborn, S.;  
486 Sauer, C.; Fritz, G.; Gebhard, S.; Mascher, T., The Bacillus BioBrick Box: generation  
487 and evaluation of essential genetic building blocks for standardized work with  
488 *Bacillus subtilis*. *J. Biol. Eng.* **2013**, 7, (1), 29.
- 489 33. Frackman, S.; Anhalt, M.; Nealson, K. H., Cloning, organization, and expression of  
490 the bioluminescence genes of *Xenorhabdus luminescens*. *J. Bacteriol.* **1990**, 172,  
491 (10), 5767-5773.
- 492 34. Galluzzi, L.; Karp, M., Whole cell strategies based on lux genes for high throughput  
493 applications toward new antimicrobials. *Comb. Chem. High T. Scr.* **2006**, 9, (7), 501-  
494 514.
- 495 35. Galluzzi, L.; Karp, M., Intracellular redox equilibrium and growth phase affect the  
496 performance of luciferase-based biosensors. *J. Biotechnol.* **2007**, 127, (2), 188-198.
- 497 36. Urban, A.; Eckermann, S.; Fast, B.; Metzger, S.; Gehling, M.; Ziegelbauer, K.;  
498 RübSamen-Waigmann, H.; Freiberg, C., Novel whole-cell antibiotic biosensors for  
499 compound discovery. *Appl. environ. microb.* **2007**, 73, (20), 6436-6443.
- 500 37. Mascher, T.; Zimmer, S. L.; Smith, T. A.; Helmann, J. D., Antibiotic-inducible  
501 promoter regulated by the cell envelope stress-sensing two-component system LiaRS  
502 of *Bacillus subtilis*. *Antimicrob. Agents Ch.* **2004**, 48, (8), 2888-2896.
- 503 38. Vesterlund, S.; Paltta, J.; Laukova, A.; Karp, M.; Ouweland, A. C., Rapid screening  
504 method for the detection of antimicrobial substances. *J. Microbiol. Methods* **2004**, 57,  
505 (1), 23-31.
- 506 39. Murphy, C. K. High throughput screen for inhibitors of the folate biosynthetic  
507 pathway in bacteria 2002 US20020164602A1.

508

