

Design of an expandable junk catcher

Final report

06.06.17

—

Edition 1

Kim A Olsen

Graded

Master's thesis in Engineering Design ... Spring 2017

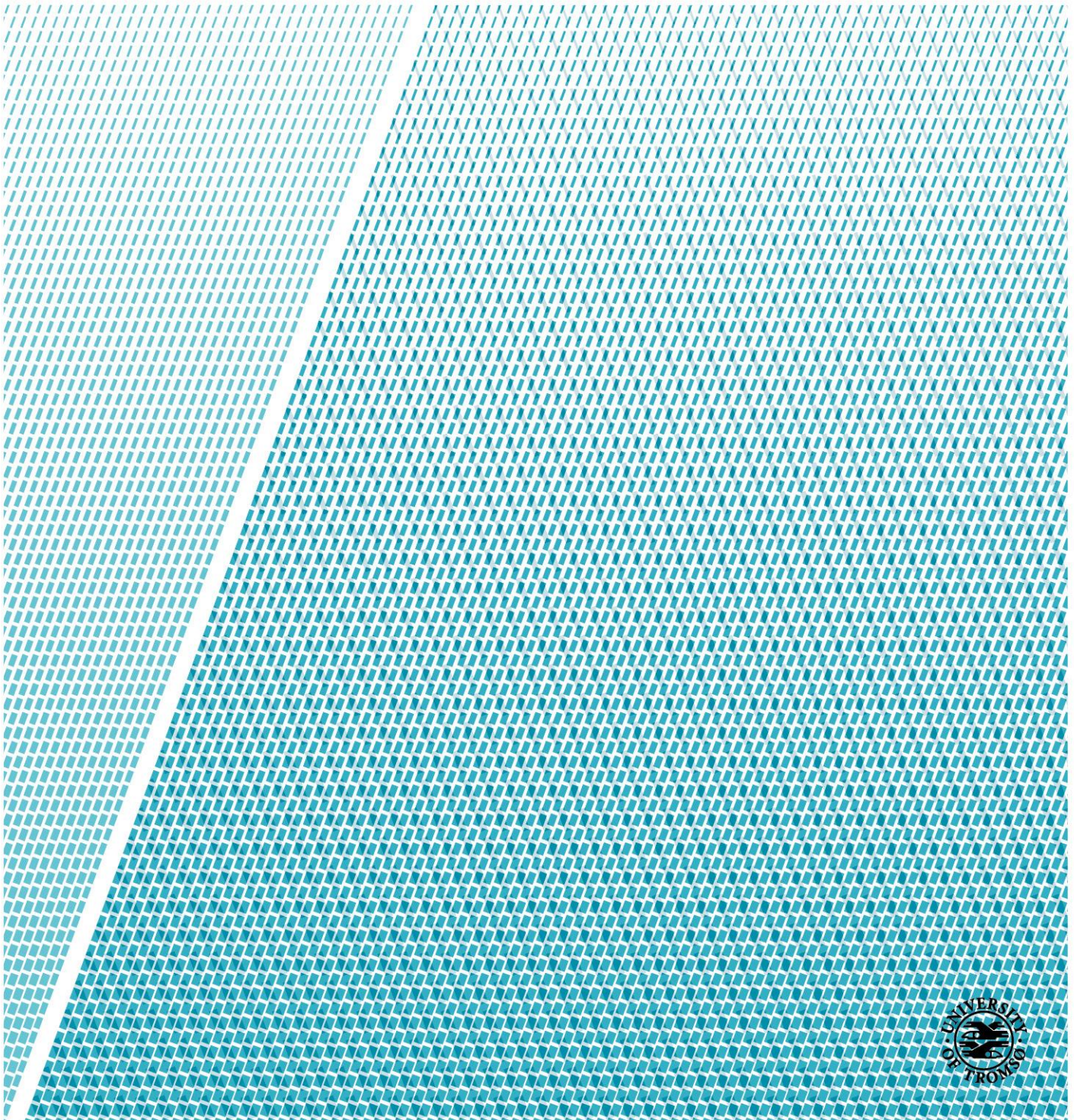

*Design of an expandable junk catcher***Preface**

The project *Design of an expandable junk catcher* is initiated by the author and Qinterra Technologies, Department of Plugs and Packers in Narvik, as a master thesis project in collaboration with UiT - The Arctic University of Norway, campus Narvik. The primary objective of the project is to develop a new design for the existing junk catcher to provide the ability to seal the annulus space when the catcher is installed, to lower the risk of getting inflicted damage to other equipment due to debris, which would significantly improve the performance of the catcher.

The project is conducted within the general specifications and restrictions defined for the subject *SHO6263 Diploma Thesis – M-ID* [1] and the special conditions applied by the Department of Engineering Design and the client/customer (Qinterra), as described in the report *Project description* in appendix 5. The project was launched on January 9th, had a duration of 5 months and was formally ended on June 6th 2017.

The master thesis project represents the conclusion of the master study and contains a combination of theoretical and practical work, in order to showcase most of the knowledge and competence acquired by the student during the master program. This includes elements such as design through scientific and creative methods, mathematical modelling, virtual prototyping (3D-modelling), material selection, structural analysis, Finite Element Analysis and rapid prototyping.

Acknowledgments

The author would like to state his sincere gratitude and acknowledge the support and guidance provided by supervisor Dag Ravn Pedersen, Senior Specialist Plugs & Packers at Qinterra Technologies and the project supervisors at UiT, Guy Beerli Mauseth, Associate professor/Head of studies – Engineering design and Andreas Seger, Scientific assistant. They have been generous with discussion, criticism and constructive suggestions, while at the same time kindly shared a lot of their great knowledge within the field of design, throughout the duration of the project. The author would also like to thank the fellow students in the 5ID class for smaller contributions to the project and brilliant discussions around both related and unrelated topics, along the entire duration of the semester.

Location: *Narvik*

Date: *06.06.17*

Kim A Olsen
Project manager

*Design of an expandable junk catcher***Abstract**

This report describes phase I of the project "Design of an expandable junk catcher", which is carried out on behalf of Qinterra Technologies, Department of Plugs & Packers in Narvik, as a part of the subject *SHO6263 Diploma thesis M-ID*. The main purpose of the project is to develop a new type of well intervention equipment to solve the problem of unwanted residue from debris on temporary installed downhole tools. Debris often consists of a mixture of sand, corrosion, scaling, oil, seawater, emulsions etc. The volume of sand and debris can be quite substantial and may cause severe problems, especially under the process of retrieving the tool from the well. Debris deposited on the tool may give trouble with the retrieval of the tool, and particles entering the mechanical parts of the tool may harm them.

To reduce this problem, Junk catchers (JC) are being used to catch and collect the sand and debris before it settles on top of the installed tool. The junk catcher with collected debris is then pulled out of the well separately, leaving a clean working environment behind. The junk catchers in use by Qinterra today primarily consist of a rigid tube in which the sand/debris can be collected. This JC has a natural flaw in its design, because a part of the sand/debris will fall down in the annulus space between the junk catcher's outer wall and the casing/tubing's inner wall. Which leads to the possibility that sand/debris may still cause problems with the retrieval of the tools, even when the junk catcher is used.

The primary objective of the project is to develop a new design for the junk catcher with the ability to seal the annulus space when the catcher is installed, to lower the risk of getting inflicted damage to other equipment due to debris. This would significantly improve the performance of the catcher. In addition, the catcher need to be centralized in the casing/pipe/formation during or after installation is completed. The developed solution must not cause problems while running in the well or during the process of retrieving the tool from the well.

The final design proposal formally called Force-Expanded Metal Flaps (FEMF) is entirely based on the idea of simplicity, reliability, self-driven all-mechanical operation and a powerful core construction. It has been a key factor throughout the entire process that the tool should be able to handle the most extreme conditions that you can expose it to. The proposal successfully satisfies all the given design specifications and requirements set for such a product. Version 3 of the concept is the final version and the suggested design proposal for a new expandable junk catcher to go with Qinterra's line of modern bridge plugs.

*Design of an expandable junk catcher***Abbreviations¹**

API	American Petroleum Institute
ATEX	Atmospheres Explosives
BHA	Bottom hole assembly
BOM	Bill of material
BOP	Blow out preventer, special combination of valves mounted on the wellhead.
CAD	Computer aided design
CEN	European Committee for Standardization
CFD	Computational fluid dynamics
CT	Coiled tubing
EBITDA	Earnings before interest, taxes, depreciation, and amortization
ESD	Emergency shut down
FEA	Finite element analysis
FEM	Finite element method
HOQ	House of quality
HWI	Heavy well intervention
HWO	Hydraulic workover
ID	Inside diameter
ISO	International Organization for Standardization
JC	Junk catcher
LIS	Lubrication Injection System
LWI	Light well intervention
MWI	Medium well intervention
NCS	Norwegian Continental Shelf
NORSOK	The acronym NORSOK was introduced in 1994, the original meaning is «the Norwegian shelf's competitive position», and aim was to cut costs and improve competitiveness for companies operating on the Norwegian continental shelf [2].
NPS	Nominal Pipe Size
OD	Outside diameter
PSA	Petroleum Safety Authority Norway
PSU	Power Supply Unit
RLWI	Riserless well intervention
ROV	Remotely operated vehicle
WL	Wireline
QFDA	Quality Function Deployment Analysis
XMT	X-mas tree ("Christmas tree"), commonly used abbreviation/term for the valve-assembly on top of the blow out preventer (BOP)/wellhead.

¹ Note! This list does not cover well-known, non-technical terminology like SI-units, currencies etc.

*Design of an expandable junk catcher***Table of Contents**

1	Introduction	1
1.1	Background.....	2
1.2	Objective.....	3
1.3	Limitations.....	3
2	Problem description.....	4
2.1	Debris.....	6
3	Current solutions	7
4	Design.....	8
4.1	Method.....	9
4.2	Requirements and demands from the customer.....	11
4.3	Objectives	12
4.4	Specifications.....	14
4.5	Function	15
4.6	Conceptual design.....	16
4.6.1	Design alternatives	17
4.6.2	Concept evaluation	19
4.7	Embodiment.....	22
4.7.1	Body	22
4.7.2	Actuator.....	22
4.7.3	Centralizer	23
4.7.4	Seal	23
4.8	Material selection	25
4.8.1	Method	25
4.8.2	Requirements.....	26
4.8.3	Body	28
4.8.4	Actuator sleeve.....	31
4.8.5	Seal and cover	31
4.8.6	Slips and actuator spring	33
5	Result.....	35
5.1	Version 1.....	35

Design of an expandable junk catcher

5.2	Version 2.....	37
5.3	Version 3.....	39
5.4	Structural calculations and analyses (FEA).....	41
5.4.1	Basis for analyses	41
5.4.2	Actuator spring – Slip mechanism	41
5.5	Manufacturing	42
5.6	Cost.....	42
6	Evaluation and interpretation	43
6.1	Design evaluation	43
6.2	Approximations in FE-Analyses	44
7	Conclusion.....	44
7.1	Material selection	45
7.2	Recommendations for further work.....	45
	Appendix	46
	Software	46
	Figures and tables.....	47
	References	49

Design of an expandable junk catcher

1 Introduction

The oil and gas industry is in a continual need for rationalization and revitalization. This creates an increasing demand for efficient and well-functioning infrastructure, both in terms of mechanical devices and structures, as well as providing a safe working environment onboard all installations. For the oil and gas to run smoothly in long pipelines and risers, it is necessary to perform regular interventions on the systems. The term well intervention covers all operations which is being executed within the wellbore, after the well has been perforated² and the production has started.

These operations may be normal procedures like service, inspection, measuring or other kinds of scheduled or necessary maintenance. It may be simple procedures like cleaning, run-in and installation of plugs, packers and other equipment or advanced mechanical and pyrotechnical work such as milling, pipe-cutting and re-perforating etc. These kinds of operations are performed frequently, reaching everything from a couple of hundred meters, up to several kilometers away from the insertion point/well head.

A very common problem connected to well intervention operations, is the large amounts of debris caught in the well. The term debris refers to substances and/or particles which originates from materials used in the well design and/or different minerals captured in the well flow. The most common types of debris are described in more detail in section 2.1. The debris will often accumulate on top of temporarily installed tools in the well and may cause severe problems with the process of retrieving the equipment from the well after it has completed its mission. This particular problem is closely described and illustrated in section 2.

² Use of a directional gun which shoots holes in the well tubular, allowing oil to flow in from the reservoir.

*Design of an expandable junk catcher***1.1 Background**

Qinterra Technologies is a Norwegian based technology company developing and supplying downhole tools and components, like tractors³ and plugs, necessary to perform intervention-operations for the global oil and gas industry. Qinterra AS is a fairly young brand, previously known by names like Maritime Well Service, Aker Well Service and Extreme Invent AS, before being acquired by the Swedish private equity fund EQT in 2014 and renamed Qinterra. Thus, the company have more than 25 years of experience delivering state-of-the-art well intervention equipment for the most extreme working conditions around the world [2]. Qinterra headquarters is located in Stavanger and the company is represented in 7 different countries. The company brought in NOK 2.33 Million in annual sales in 2015 and presented an EBITDA⁴ of NOK 520 Million (2015) [3]. In Norway, Qinterra Technologies is the main supplier of downhole tools to their sister company ALTUS Intervention, which is a leading service company in the North Sea basin. Qinterra Technologies and ALTUS Intervention, both subsidiaries of Qinterra AS, have about 1100 employees, of which 2/3 are field engineers.

Well maintenance and P&A-operations is the main field of action for Qinterra Technologies, this niche market consists of work connected to research and development with respect to equipment, tools and procedures used for maintenance services and plugging and abandoning wells. The market for these types of operations are currently increasing due to a lower oil price and a greater collective pressure from the government in each respective country. According to estimates made by the Norwegian Oil and Gas Association, over 3000 wells needs to be permanently sealed in the future, in the North Sea alone [4]. This example shows that it is great future possibilities in the P&A market alone. An increase in exploration activity over the years to come leads to a considerable number of new wells being drilled and commissioned, which will contribute to keep the market for well services and P&A-operations at a relatively stable level in the future.

³ Motorized tool with internal propulsion system (wheels or belts) for transport of other additional tools.

⁴ Earnings before interest, taxes, depreciation, and amortization.

*Design of an expandable junk catcher***1.2 Objective**

The overall objective for the project “Design of an expandable junk catcher” is to design and develop a new solution to gather and collect debris accumulated in the wellbore before it settles on top of downhole tools temporarily installed in the well. Thus, preventing debris from accumulating on top of the tools and at the same time ensure reliable protection of exposed vulnerable components, thereby ensuring proper functioning of the installed equipment. The final result should be well-documented in a scientific report.

The objective for the student is to gain maximum learning outcome from the project, while at the same time acquiring necessary competence to carry out an individual project within a discipline relevant to the education, which includes some or all of the following topics; design methods, mathematical modelling, virtual prototyping (CAD), material selection, structural analysis (FEA) and rapid prototyping.

1.3 Limitations

The project is limited to cover the development of an expandable junk catcher, compatible with the existing well intervention equipment from Qinterra Technologies. The methodology covered in this project includes a preliminary study of the theoretical background and basis for the technology concerned with well intervention operations, the equipment and methods used, as well as a thorough investigation and explanation of the core problem considered in this project. It also covers a brief investigation into the field of well intervention equipment (state-of-the-art-investigation), an analysis and development of requirements, specifications and definitions provided by the customer, given standards, regulations, norms, guidelines and practical experience that applies to the problem. As well as research within the field of patent protection of existing solutions and the market potential for such equipment.

The design methodology used is a crossing between The Rational Method by Prof. Nigel Cross (primary source) and the engineering design principles by Dr. dipl. ing. Vladimir Hubka (secondary source) used to develop design objectives, functions and requirements for the product, conceptual design, concept evaluation, embodiment of chosen concept and a detailed design proposal. In addition, Michael F. Ashby's method for material selection was applied in the scientific process of selecting suitable materials for all applications. The method is presented in the book *Materials Selection in Mechanical Design* [5].

Design of an expandable junk catcher

2 Problem description

A common problem which often occurs during well intervention operations, is large amounts of debris in the well caused by sand, corrosion, scaling, emulsions etc. The debris will often fall on top of the tools temporarily placed in the well and they may cause severe problems, like trouble with reaching the tools fishing neck⁵ or particles entering the tools mechanical parts. The problem is present in both traditional vertical wells and the more challenging horizontal wells, which are commonly used today, but it occurs most frequently and to the greatest extent in vertical wells, due to gravitational forces.

To reduce this problem, specially designed tools called **Junk Catchers (JC)** are being used to catch and collect the sand and debris before it settles on top of an installed downhole tool. The junk catcher with collected debris is then pulled out of the well separately, leaving a relatively clean working environment behind. However, a part of the sand/debris will fall down in the annulus space between the junk catcher's outer wall and the casing/tubing's inner wall. This leads to the possibility that sand/debris may still cause problems with the retrieval of the tools, even when a junk catcher is being used. By adding a system which is able to seal the annulus space when the junk catcher is installed, the performance of the catcher will be significantly improved. In addition, it will be very beneficial to be able to centralize the catcher during, or after installation is completed. The design of the solution must not cause problems while running in the well or during retrieval of the catcher. Based on this information, the following problem statement has been set for the project:

What is the best way to prevent debris from causing problems and potential damage to downhole tools temporarily installed in a well?

To highlight the problem a bit further it's necessary to look at a more general case, like the one illustrated in Figure 1. The upper left figure (1) shows a recently installed bridge plug in a normal vertical well environment. After a while debris start to accumulate in the wellbore close to the tool, due to gravitational forces acting on the particles (2). The volume of debris can be quite substantial and a lot of it will eventually cover the plugs fishing neck (red ring in 2) and possibly cause major problems with the retrieval of the temporary installed plug. This may be solved by installing a junk catcher in the well, but the junk catchers in use by Qinterra today primarily consist of a rigid tube in which the sand/debris can be collected. A lot of the debris will pass the junk catcher in the annulus space between the catcher and the casing (3) and accumulate upwards from the bridge plug seal. This residue is still left in the space where the seal-mechanism (illustrated by the blue squares) is going to collapse and may therefore still cause future problems with the retrieval of the plug and catcher (4). This is the main area of possible improvement for the existing product.

⁵ A coupling feature to pair the tool with the retrieval-equipment.

Design of an expandable junk catcher

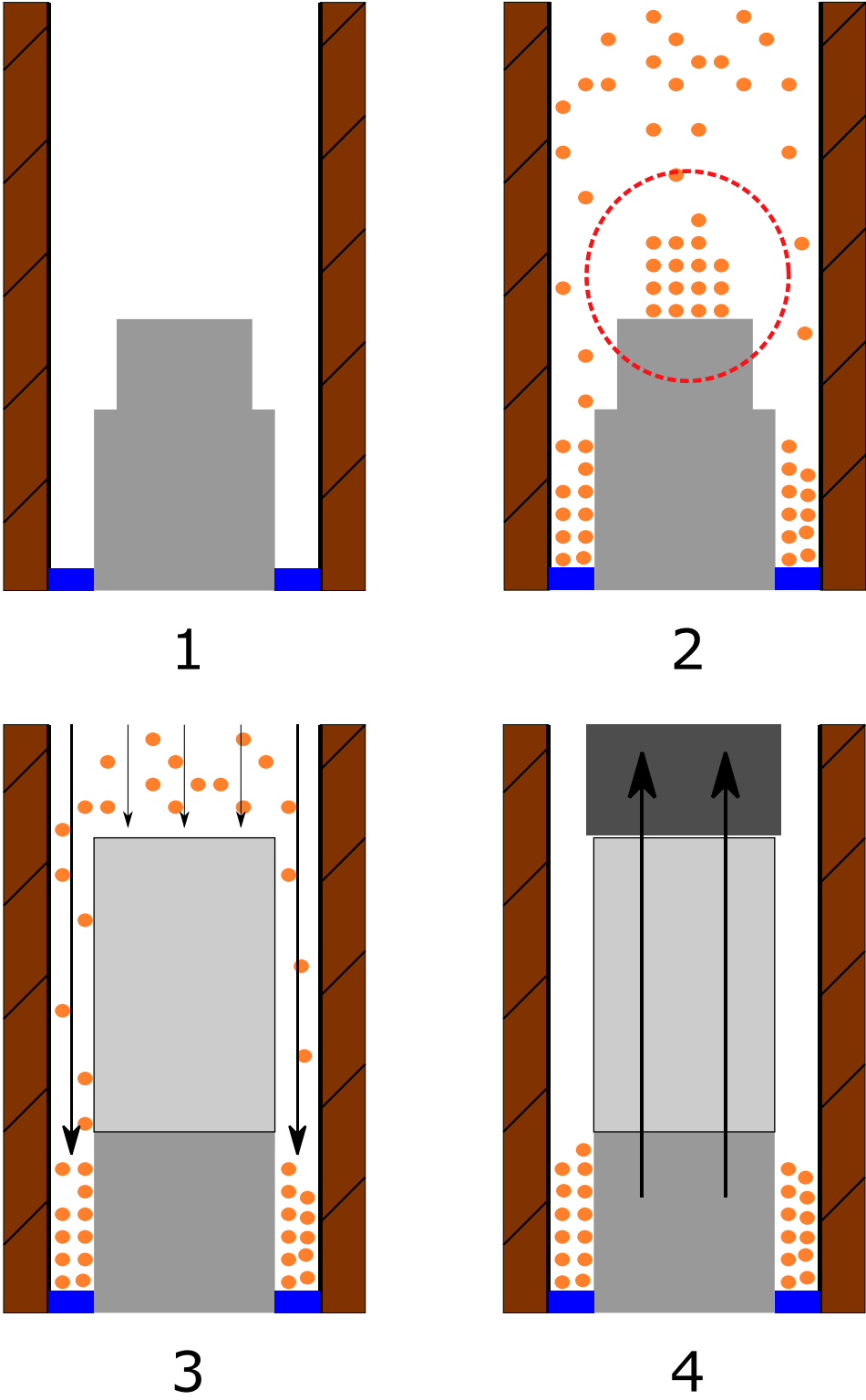

Figure 1 - Problem area: Plug installed in wellbore (1), accumulation of debris on top of plug (2), rigid junk catcher installed (3), residue from debris is left in critical spaces during retrieval of the work string (4).

*Design of an expandable junk catcher***2.1 Debris**

Debris is a collective term used to describe several different themes depending on the context, like, “the remains of anything broken down or destroyed, ruins, fragments, rubbish, accumulation of loose fragments of rock etc.” [6]. In connection with the problem described in this thesis, it’s more accurate to state that debris refers to “broken or torn pieces of something larger” [7], which in this case is related to materials, minerals, fluids or combinations of this in different ways. The collecting tools in use by Qinterra today has the ability to collect and store debris varying over a relatively large span in size and shape. The minimum debris size contained by today’s most sophisticated version is 0.002 mm (silt) [8].

Debris in oil and gas wells often consist of grains of **sand** from the formation within and around the reservoir. The grains of sand vary in size, shape and mineral composition, but the amount of it is often quite substantial. Sand makes up for most of the debris in today’s wells. Another large contributor to the overall amount of debris is scaling. The term **scale** describes mineral deposits or residue of such on the inner walls of the well tubing. Scale is created due to a chemical reaction between the pipe material and some of the chemical components in the well flow. It occurs most commonly in wells which has a large rate of produced water from the reservoir. Produced water is fractions of water which is being retrieved from the reservoir together with the hydrocarbons, very common if water injection is used as a measure to maintain a stable reservoir pressure and/or extend the life of the well.

Metal residue is also quite common in the well environment, most of this originates from **corrosion** of the metal casings and tubulars in the well. In addition to remains of wear and tear from friction between the tools and equipment used in the wellbore and the casings inner wall. Particles from corrosion is one of the biggest contributors to a lot of the total amount of debris in the well. Other environmental contributors to the growth and development of debris is **emulsions** consisting of mixtures of oil, gas, seawater, produced water, asphaltenes, waxes etc. in the well flow.

In addition to normal emulsions, the occurrence of a substance commonly called **Black sticky stuff (BSS)** is increasing. BSS is a term describing deposits made from mixtures of minerals and organic materials. How BSS forms has never been fully understood, but several samples of the substance have been collected from active wells for analysis purposes. It was discovered that high levels of iron oxides are forming the main component. The mix with organic compounds is what binds the material together and transforms it into a highly viscous dark dough. The exact composition of BSS varies from well to well [9]. Like scale, BSS occurs most often in wells which use water injection as a reservoir primer system, and thereby has a large rate of produced water in the well flow.

Design of an expandable junk catcher

3 Current solutions

Normal rigid junk catchers are available from a variety of suppliers around the world. The design of these models is often quite simple and doesn't offer any flexibility or solution to the problem at hand, as described in section 3 Problem description. The normal junk catcher design is basically consisting of a tube with one open and one closed end, so that it forms a "bucket" in which the debris is collected. Qinterra Technologies have such tools in their portfolio already, like i.e. the **PrimePlug™** with additional junk catcher [10]. The current tool is usually deployed together with the bridge plug in a single operation, similarly to the solution delivered by Interwell, which is mentioned in more detail below.

Examples of other junk catcher designs can be found from a lot of different suppliers all around the world. One of these is **Oilenco**, which supplies a complete line of junk catchers, from the simple **Tubing Anchor Catcher** [11], a normal rigid junk catcher which like the models supplied by Qinterra, is not able to seal the annulus space. To meet that demand Oilenco offer the more advanced **Medium Expansion Junk Catcher** [12], which gives the ability to seal the annulus space in wellbores which are relatively close to the tools outer diameter. They also offer the highly sophisticated **High Expansion Junk Catcher** [13], which serves a larger span in tubing diameter and provide a great flexibility for collecting debris in wells with a varying range of casing diameters.

Another example of a modular junk catcher design is the **Expandable Junk Catcher (EJC)** [14] and **Expandable Junk Catcher Add-on (EJC-A)** [15], two versions of a low- to medium-expansion junk catcher from the Norwegian supplier **Interwell Technology AS**. The **EJC** is a stand-alone medium expansion junk catcher which may be deployed everywhere in the well by itself, while the **EJC-A** is an add-on to their line of bridge plugs. The **JC** add-on provides the opportunity to deploy both the plug and the junk catcher in a single operation by the same setting tool, similarly to the systems delivered by Qinterra. This is a major cost-saving measure for deployment into deep and/or horizontal wells, because deployment in such wells often requires a lot of tractoring⁶. Tractoring is both expensive and time-consuming in itself and deployment of a non-add-on **JC** would require two complete runs of the full wireline work string down to the installation point. Hence, representing approximately "twice" the cost compared to a single deployment operation.

The examples mentioned above is only a brief excerpt of the relatively vast number of available products on the market today. Corresponding systems are delivered from a wide range of suppliers all around the world. The research into patent protection of existing solutions is presented in the report *Phase I – Theory, background and design development*, enclosed to this report as an external appendix.

⁶ Deployment by tractor, used in horizontal wells where gravity doesn't provide natural downforce.

Design of an expandable junk catcher

4 Design

Humans have designed and developed things at all times. Right from the early Stone Age tools and equipment have been developed to solve problems and to be used for different purposes. This is one of the main characteristic features of the modern man. As the new inventions were being used, errors, omissions and desired modifications were detected. The ability to translate these into concrete solutions is what forms the essential basis for the entire design profession.

The basic idea behind the field of design in general, is to develop a plan behind the creation and establishment of a new product, a system or a solution. There is a lot of various aspects that needs to be considered in this process; like objectives, functions, customer/user requirements and desires, regulatory requirements/standards/regulations etc.

The design process is a non-linear and iterative process where one often must go through many of the steps in the process several times (iterations). To do this one needs to first find an adequate solution, use and try it, then go back and assess how well the solution met the preconfigured requirements, under the given conditions. If one is not satisfied with the outcome, one must go back and restart the process again. Just like a loop in a roller coaster at the amusement park, many of the iteration steps often ends right back at the same point as it started.

An overall design principle for the design and development of all well intervention equipment may be extracted from NORSOK standard D-002:2013, which states that “*no single failure shall entail a life-threatening situation for the involved personnel or lead to significant material or environmental damage*”. This shall form the basis for definition, revision, reduction and acceptance of risk with regard to all well intervention activities. As specified by the statement, “*The design and layout of well intervention equipment shall ensure a safe and efficient workplace*” [16].

It also states that well intervention equipment and/or systems includes, but is not limited to, equipment falling under the scope of the standard, auxiliary equipment, equipment permanently installed on the location and operational procedures. In addition to this it's specified in the standard that all well intervention equipment shall be designed in such a way that it's able to withstand all loads it may be exposed to. All limitations shall be communicated to and known by the user/operator [16]. This leads to an unalterable requirement for complete documentation of all developed solutions, alternatives and products that may result from this project.

*Design of an expandable junk catcher***4.1 Method**

Design work is often divided into two different sections or methods, the creative approach and the rational approach. The creative approach leaves the designer with a lot of freedom to think out of the box, but it will be difficult to determine when a solution is sufficient and complete. The method will also be quite time consuming. Therefore, one would seek a more systematic approach to perform design work, hence the terms *design method* and *rational method* comes to mind. The aim of the rational method is often similar to the creative technique, such as widening the search space for potential solutions. Many designers are skeptical and suspicious to the rational method, because they fear it will become a killer of creativity. This is a misunderstanding of the intentions and purpose of systematic design, which is meant to improve the quality of design decisions, and hence the final product. Creative and rational methods are complementary aspects of a systematic approach to design, helping the designers improve their work.

Professor Nigel Cross is one of the leading personalities in the field of design and design thinking. He has been a member of the renowned Open University in UK for many years, where he has been involved in the process of developing a variety of relevant subjects and courses to educate people within the design discipline. His research is mainly to study the ability to develop good design skills, and how to go the long way from amateur to expert. Prof. Cross is also former chief editor of the magazine *Design Studies*, one of the world's leading journals in research on design and design methodology [17]. The scientific design method Cross presents in his own book *Engineering Design Methods: Strategies for Product Design* [17] is called “The rational method” and it is based on working with different parts of the process separately, and then combine the different results from each of the processes systematically, until the final goal or result is achieved. The process is divided into eight parts, which are referred to as «Stages» in the book, as described in the window below.

1. Identifying opportunities
2. Clarifying objectives
3. Establishing functions
4. Setting requirements
5. Determining characteristics
6. Generating alternatives
7. Evaluating alternatives
8. Improving details

If one looks at the stages or steps in The Rational Method in a larger overall context with the rest of the process included, as illustrated in the model shown in Figure 2. It's easy to see that the model shows the stages as an internal loop which interacts symmetrically with the four points in the outer loop, which symbolizes the problem at hand and the problem-solving process itself. This states that the method is a complex system, with internal processes arranged according to a specific sequence of action, hence the custom numbering and order of the stages.

Design of an expandable junk catcher

Figure 2 - The Rational Method - Overall Model [17]

In the first five steps of the process, requirements and specifications for the product is identified. This must be determined before design alternatives and concepts can be generated. The remaining work is mainly concentrated on the development of sufficient concepts for the design of the product. These will also form the basis of the analysis and evaluation of the design alternatives, with the aim to improve and modify certain key details. This process is repeated several times to get as close as possible to an optimum design concept, which will satisfy all the requirements, objectives, features and specifications that have been established in this phase of the project.

There is a wide range of rational design methods, covering all aspects of the design process from problem clarification to detailed design. The Rational method by Prof. Nigel Cross is chosen as the primary design method for this project and because some of the elements in the method are presented in a similar way by Vladimir Hubka in his book *Principles of engineering design* [18], it's been decided to combine these two methods. Cross' design method should be used as the primary basis for carrying out the design work for the project, while Hubka's method will work as a secondary source. In addition to this, Michael F. Ashby's method for material selection was applied during the process of selecting proper materials for all parts. This scientific method is presented in the book *Materials Selection in Mechanical Design* [5]. The method utilizes information gathered from the software *CES EduPack* or the theoretical material presented in the book, in order to select materials with the help of graphical charts and computer algorithms.

*Design of an expandable junk catcher***4.2 Requirements and demands from the customer**

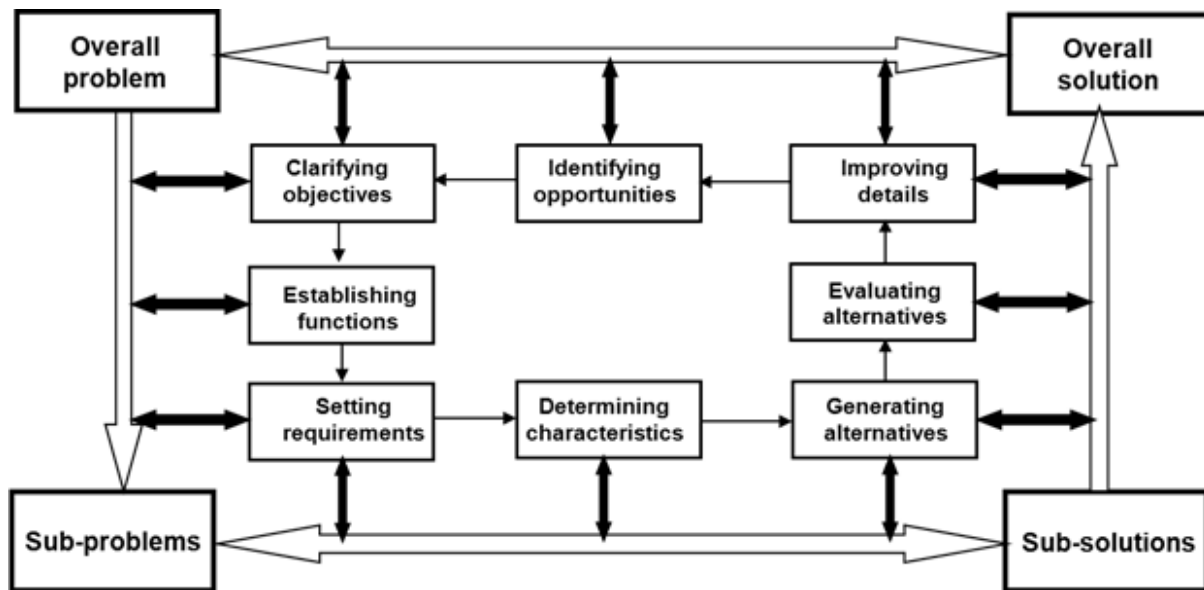
In the initial phase and first stages of any design process it's important to get a good understanding of what the customer wants from the product, what requirements the new product must satisfy and which improvements can be made to ensure that the product is optimized for the assigned purpose. The demands and requirements set for the new product is presented briefly in Table 1. All the mentioned factors and parameters, which are formed with basis in the customers' demands, as well as the physical restrictions given by the environment in which the tool will be operating, will be significant aspects in the process of developing the overall specifications for the product in a later stage.

It needs to be taken into consideration that the product is not supposed to be handled by a single user only, it's also going to be in contact with other personnel who will make it, assemble it, service and recycle it.

Table 1 - Design requirements and demands provided by the customer

Function
<ul style="list-style-type: none"> - Seal properly between outer body and annulus, shall not seal differential pressure. - Centralize tool in well tubular (Before/during activation/deployment) - Simple mechanism - Durable - Not be obstructed by sand, dirt, debris, foreign objects or impurities - Few parts/components - Flexibility – Ability to scale to various tube/pipe dimensions (NPS 4,5", 5,5", 7", open well/formation) - Run-both ways unrestricted - Ability to pass obstacles/deposits/constrictions
Operation
<ul style="list-style-type: none"> - Simple operation - Module-based design (Deployment together with other tools in a single operation) - Adaption to existing tools/equipment
Material/Weight
<ul style="list-style-type: none"> - Load conditions (Pressure, temperature, forces) - Dimensions – Slim construction for easy run in well - Weight – Low/Reasonable
Environmental factors
<ul style="list-style-type: none"> - Corrosion resistant materials - H₂S-resistant
Safety
<ul style="list-style-type: none"> - Emergency/Backup solution - Reliable construction
Maintenance
<ul style="list-style-type: none"> - Few, simple parts/components - Simple construction - Easy to dismantle/assemble
Regulations
<ul style="list-style-type: none"> - Standard ISO14310:2008 and ISO15156:2015
Cost
<ul style="list-style-type: none"> - Cost/Benefit - Prototype production/testing - Customer wants this tool in their portfolio

*Design of an expandable junk catcher***4.3 Objectives**

In any design process, it's very beneficial for the designer to get a good understanding of the *design objectives*. It is possible to go through a design process without it and end up with a finished product, this leaves the designer with a lot of freedom to make decisions based on the knowledge he or she possesses on their own. A lot of the considered aspects and factors which have an influence on the design process will alter and change during the duration of the project. The initial and interim objectives may change, expand or contract, or be completely altered as the problem becomes better understood and as solution ideas start to develop. So, as an aid to better control and manage the design process it's important to always have a statement of objectives which is as clear as possible. This statement should be in a form which is easily understood and which can be agreed on by the various members of the design team [17].

The aim at this stage of the design process is therefore to clarify the design objectives at all levels, assign them to a hierarchical position with basis in their level of importance for the products performance and the value created for the customer. The hierarchical arrangement of the objectives will also contribute as a basis, to graphically show the relationship between the objectives and the sub-objectives. The objectives is often a combination of customer requirements, user needs and product purpose, but whatever they are called, they consist of a mixture of abstract and concrete aims that the design must try to satisfy or achieve [17].

The method which is being used for this purpose is the *Objective tree method*, which is a graphical representation of the arrangement described above. The output from this is illustrated in Figure 3. If you read the tree from top to bottom it shows you the "how" to reach each objective, while if you read it from the bottom up, it shows you "why" you want to reach it and the reason for it being a sub-objective. The process of arriving at the final result (objective tree) helps to fully clarify the objectives and to reach an agreement between the client/customer, the manager and the designer or members of the design team. In order to expand and clarify the main objectives, three main questions may be useful in the process, the "why?", "how?" and "what?" [17].

The objectives chosen for the development of the expandable junk catcher is based on the three main objectives *Design*, *Function* and *Cost*. These have been further developed and expanded into several different sub-objectives which take a lot of important aspects into consideration. Most of the sub-objectives is assigned their position in the hierarchy based on their priority from the customer's point of view, which were explored in close detail in the previous section. Requirements which are greatly regarded in relation to this is aspects like, durability, safety, simplicity and adaptivity, which can be seen from their place in the objective tree.

Design of an expandable junk catcher

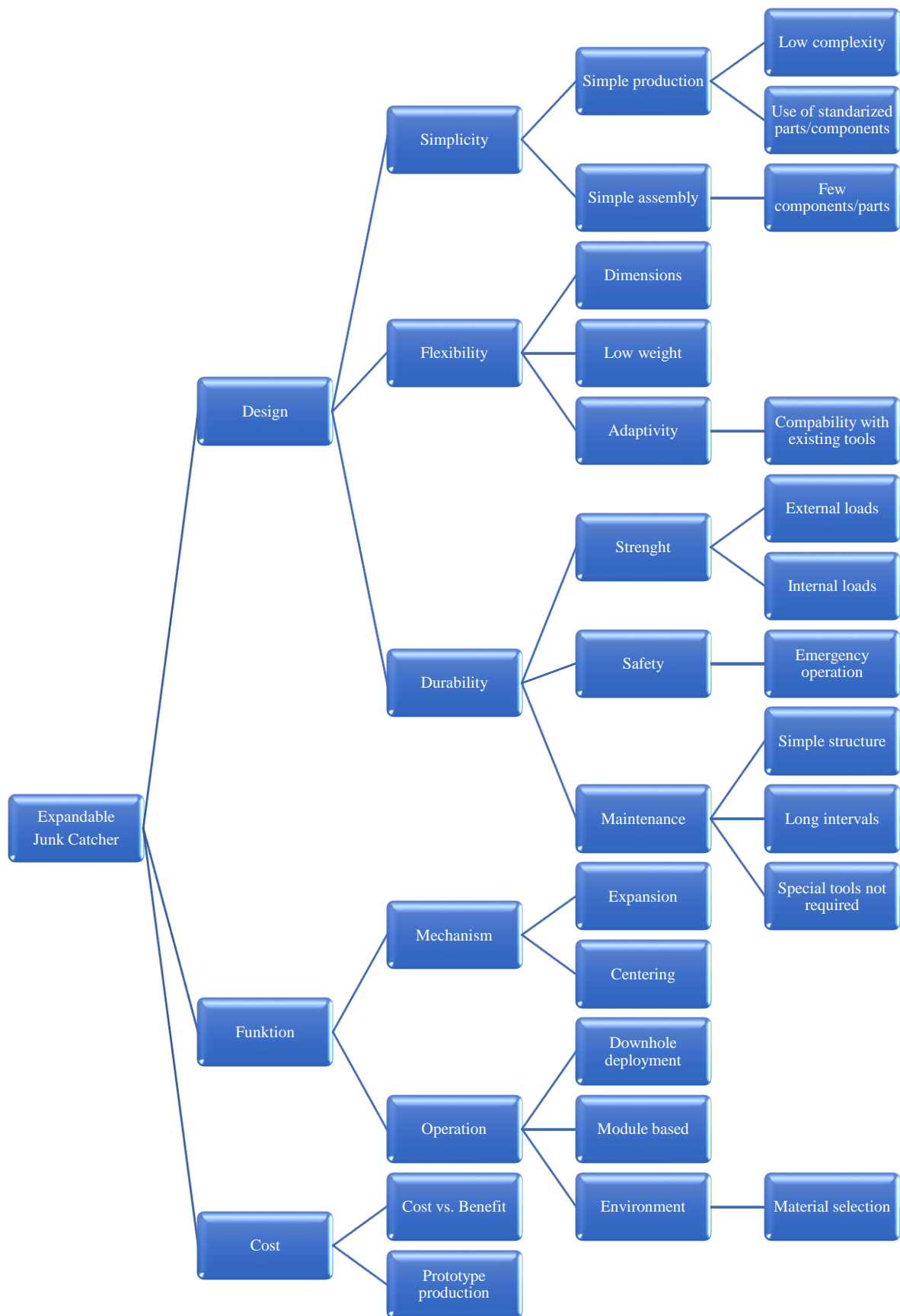

Figure 3 - Objective tree for design of an expandable junk catcher

*Design of an expandable junk catcher***4.4 Specifications**

Statements of design objectives and/or functions (such as those described in section 5.3 and 5.5) are sometimes regarded as being mostly performance specifications, but that is not really the case, because objectives and functions are statements of what a design must achieve or do. Hence, they are not normally set in terms of precise limits, which a performance specification requires in order to be correct [17]. In order to develop a complete set of design specifications, it was agreed on by the supervisor to focus only on one of the specific tool sizes, so that it's possible to determine the correct physical properties, like measurements, weights etc. From that point and onwards are all specifications and design features optimized to fit the 4.5 inch version of the tool. This is the smallest diameter used for this application today. Throughout the design and concept development stages it's important to keep in mind that all solutions must be possible to modify or scale upwards to fit the larger versions of the tool (the 5.5 and 7.0 inch).

It's essential to the development process that the design specifications is neutral with respect to solutions [5]. But, since this is a special case, with great focus on safety and high reliability demands in a relatively concentrated market, some design characteristics and features are stated as direct requirements. The requirements are classified and ordered into classes, fixed requirements, minimum requirements and desires. This procedure provides the basis for using the elaborated requirements as a part of the evaluation criteria's in later design stages [18]. The majority of the specifications is developed with basis in the general demands, requirements and wishes presented by the customer (section 5.2), to secure full compatibility with their existing line of products, the stated design objectives and the formal regulations presented in the standards: *NS-EN ISO 14310:2008 Petroleum and natural gas industries - Downhole equipment - Packers and bridge plugs* [19], *NORSOK D-002:2013 Well intervention equipment* [16], *API Specification 11D1 - Packers and Bridge Plugs - Third edition* [20] and *NS-EN ISO 15156:2015 Petroleum and natural gas industries - Materials for use in H₂S-containing environments in oil and gas production - Part 1-3* [21-23].

The well parameters are forming the physical restrictions and will act as the most important constraints for the product, while the well environment in which the tool is supposed to operate in, plays a vital role in especially the material selection process. The well environment is also forming an overall frame around all developed design features and it therefore needs to be described very closely, as stated in the standard NS-EN ISO 14310:2008.

The user/purchaser shall identify the density, chemical/physical composition, and the condition of the fluid and/or its components, including solids (sand production, scale, etc.), liquid and/or gaseous, to which the packer or bridge plug is exposed during its expected life cycle [19].

This is thoroughly investigated and explained in both section 2.1 *Debris* and shown in the Specification sheet in appendix 1. Emphasis has been on developing the most complete list of requirements and specifications in order to restrict the number of possible solutions by iteration.

*Design of an expandable junk catcher***4.5 Function**

In order to determine the functional structure for the design of a new technical system, it's beneficial to utilize a function analysis method. The method presented by Cross [17] provides the means necessary to fully consider all the essential functions which the product is set to accommodate and the level at which the problem is to be addressed, without considering the potential type of solution to fulfill and satisfy these requirements. This leaves the designer free to develop alternative solution proposals which fulfill the functional requirements. Cross defines the essential functions as *those that the device, product or system to be designed must satisfy, no matter what physical components might be used* [17]. To represent the results of the function analysis it's common to use the "Black box model", which shows the connection between input, the overall function and the output. The black box model is a part of Cross' established *Function Analysis Method* [17] and it contains all the functions necessary for converting specific inputs into the desired outputs.

It's preferable in the beginning to make the overall function as broad as possible and then if necessary, narrow it down later, until the core of the functional structure is reached. An unnecessary limited overall function might restrict the number of possible solutions in the early phase, similar to a too restricted list of design specifications.

The **input** for the overall function of the expandable junk catcher is regarded as "*the operation of hoisting the complete work string down into the well through the sluice mounted on the well head*". While the **overall function** of the system is to,

"Gather and collect debris accumulated in the wellbore before it settles on top of downhole tools temporarily installed in the well and at the same time ensure protection of exposed vulnerable components, thereby ensuring proper functioning of the same tools".

The functional **output** in this case is actually almost the exact opposite of the input, hence "*the operation of hoisting the work string back out of the well*". To additionally explain the functional structure of such a technical system it's often beneficial to investigate the inner means of the black box function model. This is mostly done by opening up the box and turning it into a transparent box, which has the same input and output measures as the black box, only now it's possible to see what's happening within the system. The transparent box shows all internal processes and operational sequences in a logical way, which makes it possible to retain information about how to solve each function or process and the logical flow routes within the system. The expanded functional analysis for the system is shown as a transparent box in appendix 2, where the functions has been divided into operational sequences and placed into the respective stage of operation which it belongs and developed to fit the predefined problem description, the measures available and the stated design requirements. The three defined stages of operation is **Run in hole**, **Deployment** (Setting) and **Retrieval**, all of which are clearly marked in the transparent box in appendix 2.

*Design of an expandable junk catcher***4.6 Conceptual design**

The conceptual design stage is the most important stage of the design process, this is where all suitable solutions for the product development is launched to provide the ability to map the amount of possible solutions, define design concept packages and assess them with regard to the predefined specifications and requirements. However, if the target range within the design specification is set too narrowly, it would significantly limit the range of acceptable solutions, and a lot of otherwise acceptable solutions might be eliminated unnecessarily and too early [17].

This step is actually among one of the most demanding ones in the field of engineering design. It requires a large amount of imagination, a wide knowledge of available technology and practical experience in the relevant field. The designer must find the *causal action chain of events* for the system, which is able to deliver the desired effects and/or actions needed (as defined by the previously established functional structure) through the effectors of the overall process. The inputs may either be chosen directly by the designer, or defined by the design specifications. The disturbances from the surrounding environment, in space and time, should also be considered. Depending on the degree of complication of the output effects, the action chains and the appropriate function-carriers will be more or less complicated [18].

In order to realize the effects in the functional structure established during phase I, it's necessary to search for effects that are usually known as *laws of nature*, depending on the existence of a *natural phenomena* which can fulfill such effects. Within these laws, the participating properties are brought into qualitative and quantitative relationships. The mode of action is located by establishing action localities (number and form) and the behavior of such. The mode of action can be altered by slightly modifying the mentioned design characteristics, by employing different possible embodiments based on the same characteristics [18].

The conceptual design process was already initiated in the last sections of the documented work from phase I (*Phase I – Theory, background and design development*), with basis in the design specifications, the requirements and demands set by the customer and the complete function analysis for the product. It also stated that the activation sequence could be executed by utilizing the axial forces created by the setting-tool during deployment of the toolstring, but that it was a great desire from Qinterra to be able to deploy the tool without the need of external force in a self-powered sequence. The conceptual specification also stated that connectivity during run in hole and deployment operations will be made through a special locking-mechanism between the setting tool and the junk catcher's base, while the connection during retrieval operations will be accomplished by use of the junk catchers GS fishneck, as specified by Qinterra.

*Design of an expandable junk catcher***4.6.1 Design alternatives**

During the design development stages conducted in phase I and II, several different solutions were mapped and put together to form functioning concept packages, by utilizing *The Morphological Chart Method* by Cross [17], as shown in appendix 3. The process resulted in four developed concepts, with characteristics and attributes as described below. The general attributes of each concept is shown briefly in Table 2. Please note that the sketches are made for illustration and assessment purposes only and therefore may not contain the correct physical properties like detailed measurements, size, scale, finish etc.

Concept 1 – Force-Expanded Metal Flaps is made up of a combination of a sealing mechanism consisting of several overlapping metal flaps, which when activated, moves outward to create the characteristic funnel shape for guiding and collecting debris. To centralize the tool in the wellbore, a slip mechanism is applied, similarly to a lot of the existing equipment in Qinterra's portfolio. Slips is a well-known, commonly used solution for anchoring and centralizing a wide range of well intervention equipment.

Concept 2 – Compressed Rubber Seal consists of a sealing mechanism which uses a rubber cylinder lined up with the center axis of the junk catcher's body, which when activated is being compressed until it turns into an elliptic shaped seal when viewed in cross-section. As a centralizing mechanism this concept utilizes the natural forces created by flexible metal bows which relies on the internal tension of the material. When activated, the outside diameter of the tool is increased by reducing the bow radius. This is done by an axial compression force, acting on the moveable bow-support, while the other one is safely secured to the body. Due to the properties of the material, proper strength and expansion may be calculated. Although, it requires some advanced mathematical modelling. Early verification may be conducted by numerical/computational simulations.

Concept 3 – Internal Rubber Funnel uses a combination of a pre-shaped rubber cylinder which, in expanded state replicates a funnel, to successfully guide debris into the container. The OD of the mechanism is kept constant during run in hole-sequence by a custom-made adapter mounted on the setting tool. The IRF uses a V-shaped arm-assembly as the primary centralizing mechanism. The sealing mechanism offers reliability through design simplicity, although retrieval operations might be harmed due to insufficient seal-collapse during GS-hookup. The rubber funnel is designed to be forced into the upper sleeve by a modified GS retrieval-tool.

Concept 4 – External Rubber Funnel uses a rubber cylinder which is being forced to the expanded state by the geometrical shape on the outer surface of the actuator sleeve, as a sealing mechanism. The rubber cylinder reaches a cone/funnel shape when fully expanded, which will effectively guide debris into containment. Just like the IRF, ERF uses a V-shaped arm-assembly as the primary centralizing mechanism, only with the applied modification of a single-material wheel mounted in the joint between the two arms.

Design of an expandable junk catcher

Table 2 - Concept illustrations

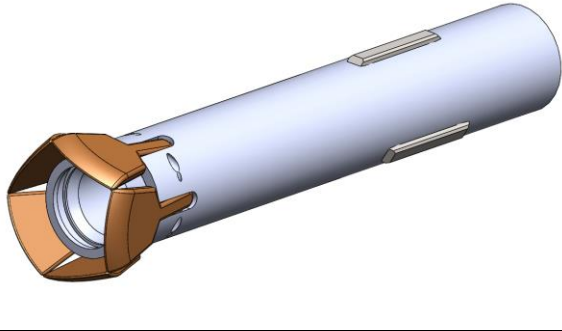
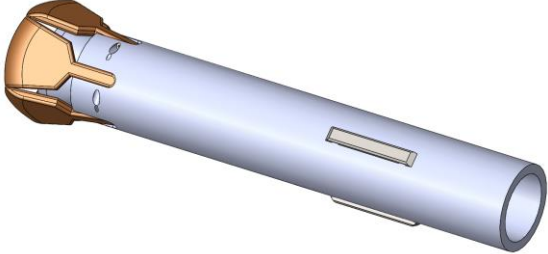
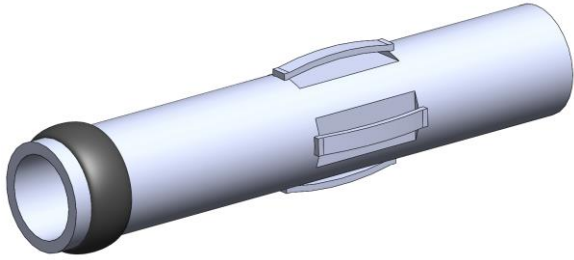
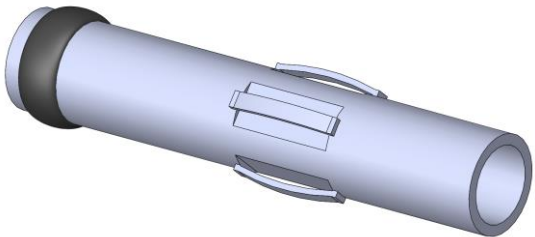
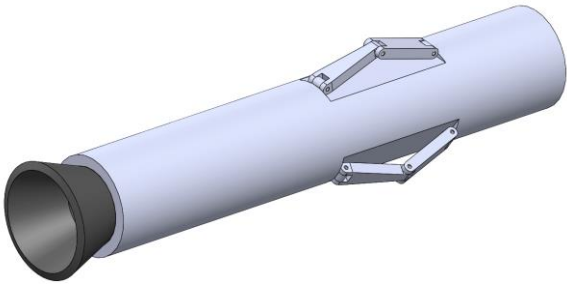
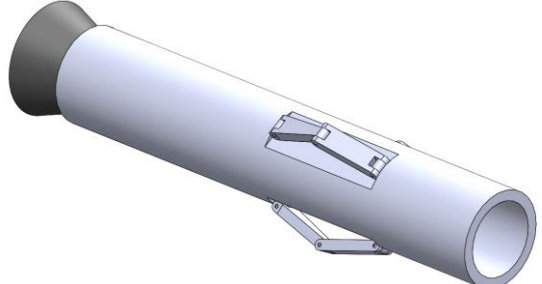
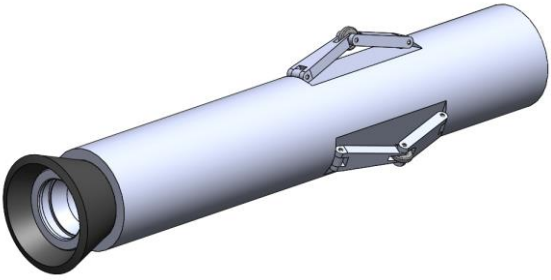
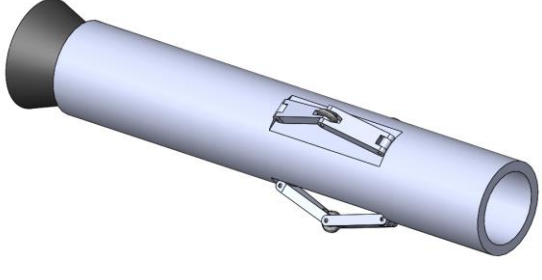
Concept 1 – Force-Expanded Metal Flaps (FEMF)	
	
Concept 2 – Compressed Rubber Seal (CRS)	
	
Concept 3 – Internal Rubber Funnel (IRF)	
	
Concept 4 – External Rubber Funnel (ERF)	
	

*Design of an expandable junk catcher***4.6.2 Concept evaluation**

When a wide range of design alternatives have been created, it's necessary for the designer to be able to select the best option. At various points in the design process there might also be decisions to be made, regarding less prioritized subjects like sub-solutions and features. Choosing the proper alternative is therefore a very common feature within design activities. The decisions and choices made, might be based on some of the following parameters, guesswork, intuition, experience or arbitrary selections. However, it's beneficial in most cases to be able to make decisions based on a more rational, or at least open procedure. This will provide the possibility of participation from external personnel, such as clients, colleagues and managers [17].

During this stage, it's important to look back at the previously stated design objectives (section 4.3). These objectives form the core of the scientific evaluation method called "The Weighted Objectives Method". The evaluation assesses the overall "value" or "utility" of the particular design proposal with respect to the design objectives. However, different objectives might be regarded as having different values in comparison to each other (based on level of priority). Therefore it often becomes necessary to have some means of differentially weighting the objectives, so that the performance of each design alternative may be assessed and compared to the others, relative to the entire set of objectives [17].

The weighted method is initiated by adding certain numerical weights to each design objective, based on its level of priority in the objective tree, as shown in Figure 4 - Weighted objective tree. The relative weights are assigned at different levels of the objective tree, such that all weights sum up to one. A control calculation of this is often appropriate, as shown in equation 1 below.

$$\sum (0,0256 + 0,0384 + 0,064 + 0,0544 + 2(0,0408) + 3(0,034) + 0,0136 + 2(0,0102) + 0,11 + 0,09 + 2(0,07) + 0,06 + 2(0,1)) = 1 \quad (1)$$

The concept packages developed with the help of the morphological matrix (appendix 3) was naturally limited with regard to the size and scope of the project, as one can generate an infinite number of solutions/concepts at this stage. The optimal result from this process is to create as many different combinations as possible. The four developed concepts described in the previous section is the basis for the assessment and the results from this process is shown in the evaluation matrix in Table 2. The following grades are being used in the assessment: 1. *Excellent*, 2. *Good*, 3. *Satisfactory*, 4. *Weak* and 5. *Inadequate*. The computation is executed by multiplying each character with the respective weight and then sum up the results. The best alternative is given by the lowest total sum at the end of the evaluation.

Design of an expandable junk catcher

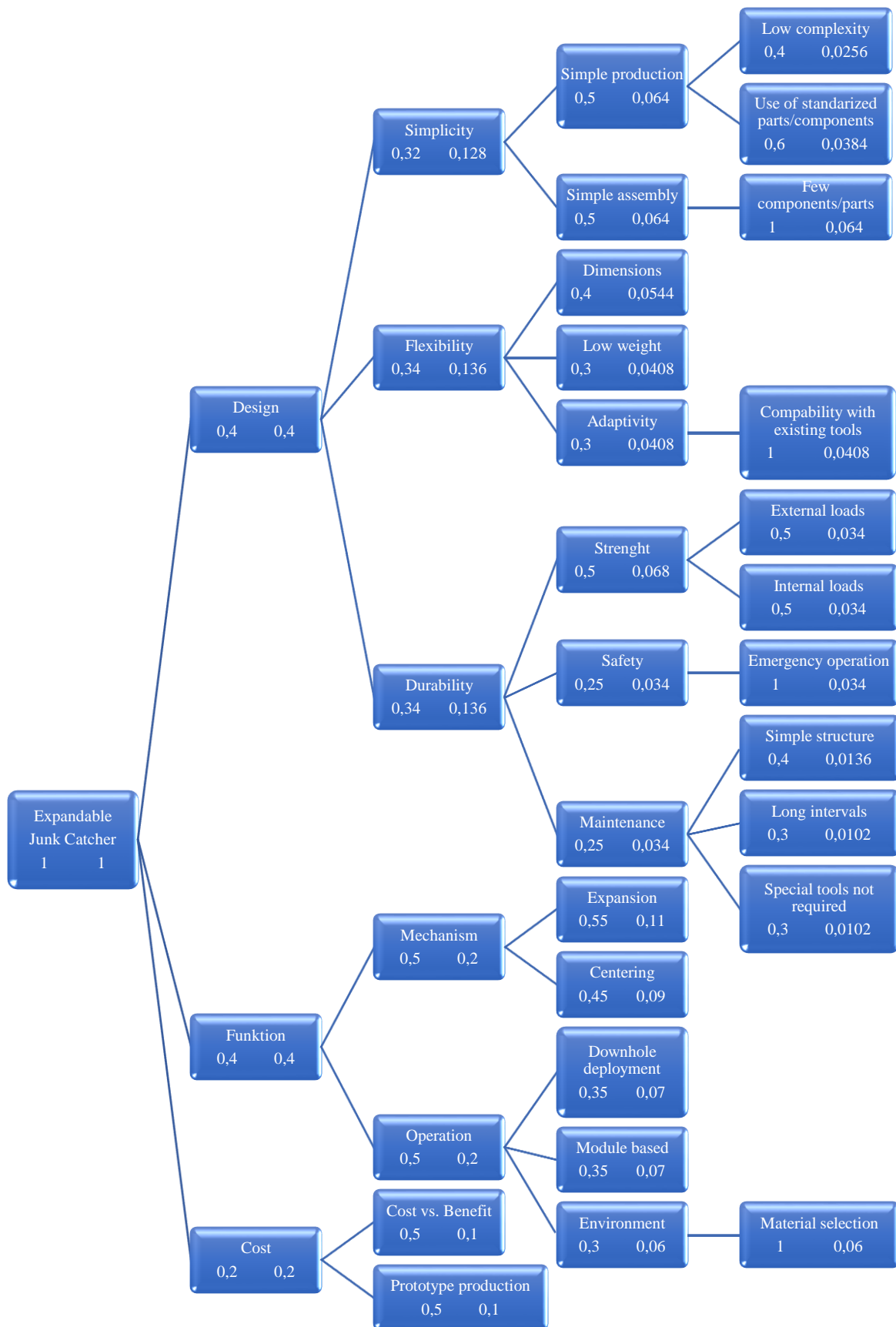

Figure 4 - Weighted objective tree

Design of an expandable junk catcher

Table 3 - Evaluation matrix

		Concept 1 FEMF	Concept 2 CRS	Concept 3 IRF	Concept 4 ERF	
Requirements/Assessment criteria	Design	0,4	1	2	2	
	Simplicity	0,128	2	2	2	
	Simple production	0,064	2	3	3	
	Low complexity	0,0256	2	2	2	
	Use of standardized parts/components	0,0384	3	3	3	
	Simple assembly	0,064	2	2	2	
	Few components/parts	0,064	2	2	2	
	Flexibility	0,136	1	2	2	3
	Dimensions	0,0544	1	1	1	1
	Low weight	0,0408	1	2	2	2
	Adaptivity ⁷	0,0408	1	2	2	3
	Compability with existing tools	0,0408	1	2	2	2
	Durability	0,136	1	2	2	2
	Strength	0,068	1	2	2	2
	External loads	0,034	3	3	3	3
	Internal loads	0,034	3	3	3	3
	Safety	0,034	2	3	3	3
	Emergency operations	0,034	3	3	3	3
	Maintenance	0,034	2	2	2	2
	Simple structure	0,0136	3	3	3	3
	Long intervals	0,0102	2	3	3	3
	Special tools not required	0,0102	2	2	2	2
	Function	0,4	1	1	1	1
	Mechanism	0,2	1	2	2	2
	Expansion	0,11	1	1	1	2
	Centering	0,09	1	2	3	3
	Operation	0,2	1	1	1	1
	Downhole deployment	0,07	1	1	2	2
	Module based	0,07	1	1	1	1
	Environment	0,06	1	1	1	1
Material selection	0,06	1	1	1	1	
Cost	0,2	3	3	3	3	
Cost vs. Benefit	0,1	3	3	3	3	
Prototype production	0,1	3	3	3	3	
Sum (Character n multiplied by the weight)		4,707	5,967	6,127	6,414	

The results from the concept evaluation, in falling order:

Best concept	–	Force-Expanded Metal Flaps
Second best	–	Compressed Rubber Seal
Third	–	Internal Rubber Funnel
Fourth	–	External Rubber Funnel

Based on these results, concept 1 is chosen as the primary basis for development of a complete embodiment, in order to get a fully detailed design proposal. Following this, a couple of early design proposals were formed at sketch level, as shown in the report (external appendix).

⁷ Modification or partial transformation of an existing machine system for new functions [18].

*Design of an expandable junk catcher***4.7 Embodiment**

The design development stages succeeding the concept phase is by many referred to as “Embodiment”. During the embodiment phase emphasis is on further developing the chosen concepts in order to use them as a basis for development of other connected aspects like i.e. choice of materials. One method for systematically executing this process is to use what Prof. Michael F. Ashby describes as a “System analysis” in his book *Material Selection in Mechanical Design* [5], where you tear your product down into small pieces (components) and analyze them bit by bit. The product or the system (technical system) may be divided into smaller sections which can be referred to as subassemblies. These subassemblies consist of a given set of components, and they may also be divided up into even smaller sections, to provide a clear basis for a more easily conducted design review. By looking into only one single component at the time.

4.7.1 Body

The junk catcher body is based around the previous design by Qinterra, where the body is mainly a rigid tube in which the debris is collected and contained. Overall dimensions and other attributes relevant to the connection between the developed upper sleeve and the base (see illustration in Figure 5) are kept exactly as in the previous design, in order to successfully maintain full compatibility with the existing equipment [10].

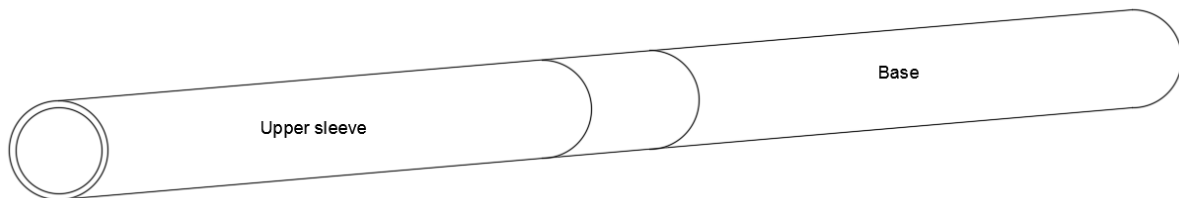
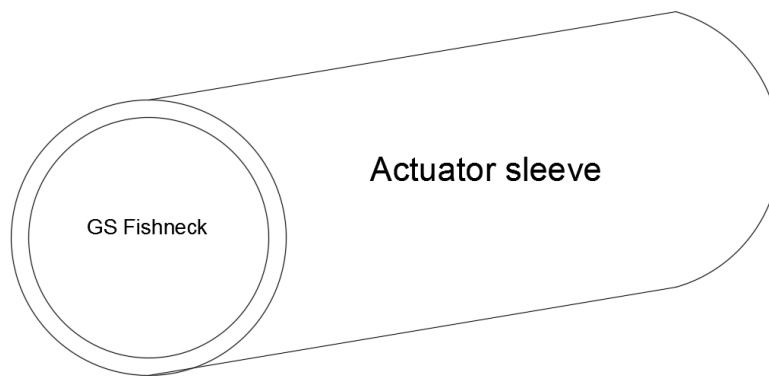

Figure 5 - Junk catcher body

4.7.2 Actuator

The actuator sleeve is based around the geometric shape of an advanced cylinder with a modified geometry which aims to activate and fulfill functions, while at the same time being able to transfer kinetic energy (motion) between the key components, as illustrated in Figure 6. The actuator sleeve serves as the main housing for the GS fishneck, which is being used to connect the junk catcher to the retrieval equipment. As presented in the morphological chart (appendix 3), it's considered to utilize the forces of a conventional spiral spring to assist the retracting or activate the deployment motion of the actuator sleeve. This leads to a demand for sufficient mounting space between the junk catcher's body and the actuator sleeve, to provide the spring with an adequate support and sufficient surfaces to efficiently transfer force between the moving parts. The actuator sleeve will be locked by locking pins as long as the setting tool is connected, to avoid unwanted activation.

Design of an expandable junk catcher*Figure 6 - Actuator sleeve with GS fishneck***4.7.3 Centralizer**

The centralizing mechanism chosen for development in concept 1 is a traditional slip design, which is already being used for several different applications within the both the oil and gas industry, as well as other related industries. A principal overview of the characteristic geometry of a normal slip is shown in Figure 7, the support, bottom angle and activation means may be altered depending on area of application.

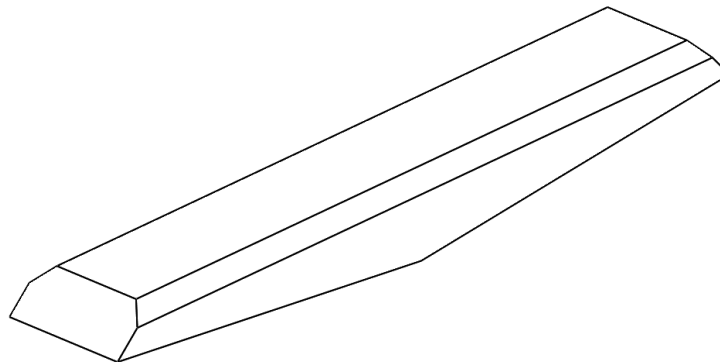
*Figure 7 - Principal slip geometry***4.7.4 Seal**

The sealing mechanism chosen for concept 1 is multiple overlapping flaps, similar to some of the current designs described in phase I. A proposal for the principal geometry of the sealing flaps is shown in Figure 8A. In order to ensure operational reliability and enhanced durability, and at the same time actively prevent the mechanism from hooking the tool during run in hole-operations, a cylindrical cover feature is added around the sealing mechanism, like the one shown in Figure 8B. The relationship between the flaps and the area which they're supposed to cover in the expanded state is in general given by the difference between the outer diameter (OD) of the junk catcher's body (3.59 in.) and the maximum diameter when fully expanded (4.10 in.), as shown in Figure 9. The area is divided into the amount of flaps needed to cover the expanded circle, eight flaps, which gives a theoretical covered sector of 45 degrees per flap. The number of flaps may be subject to change.

Design of an expandable junk catcher

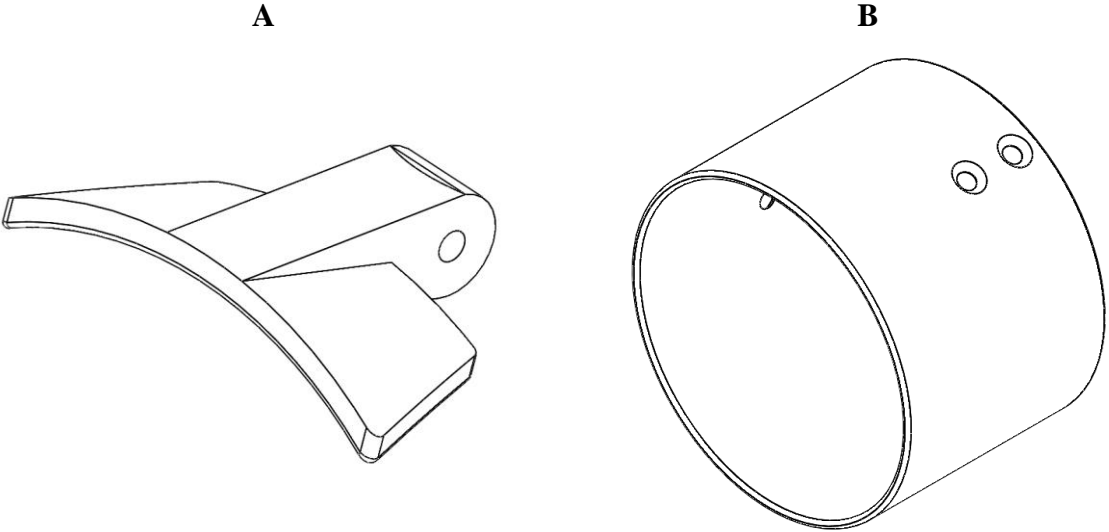

Figure 8 - Seal mechanism - Principal flap geometry (A) and flap cover (B)

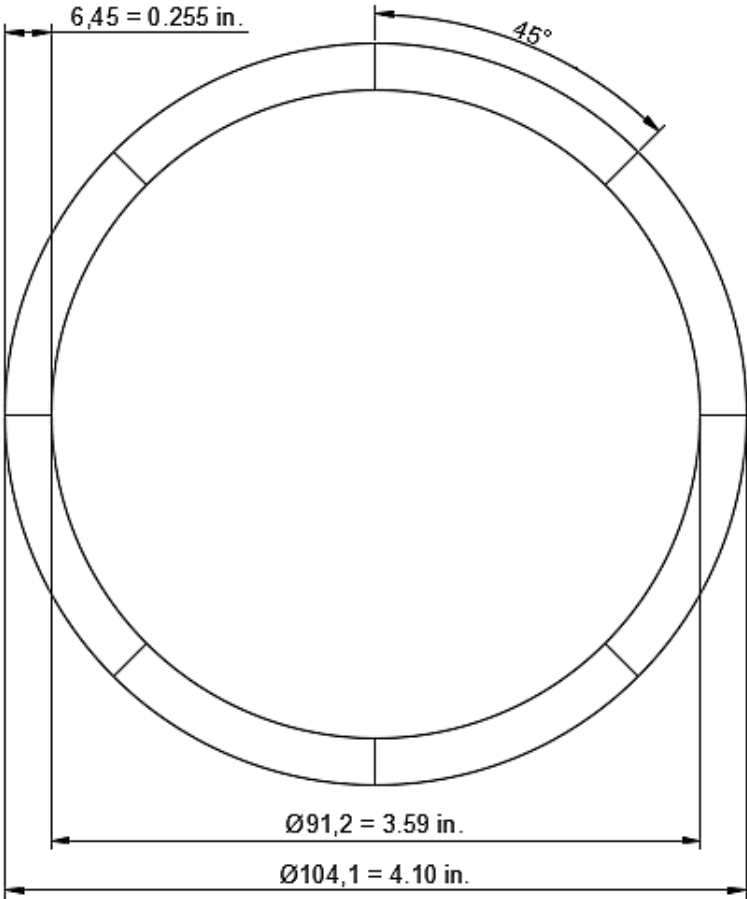

Figure 9 - Area covered by expanded flaps

*Design of an expandable junk catcher***4.8 Material selection**

Materials and structures are continuously being improved through different innovations within the field of material technology. Earlier, near all materials were manufactured from known substances made up of only the natural elements. Over the recent years we've seen a major leap forward in the development of new materials like high performance metal-alloys, bio-degradable materials and synthetically manufactured materials. It's normal to divide materials into the following six groups; metals, ceramics, glasses, polymers, elastomers and composites.

The selection of materials within the field of design cannot be made without taking into consideration the choice of process by which the material is going to be shaped, joined and finished. At this level cost also enters the equation (see section 5.5), both in connection with the choice of material, as well as in the way the material is processed. The number of available materials today is vast, over 160,000 possibilities [5]. To choose from such a rich and varied menu, it's important to have a good scientific method to rely on.

The main objective in this stage is to find the best suitable materials, to be used for all the parts that is going to be manufactured. The product will be used in varying subsea applications and the environmental factors connected to deep wells (oil and gas) is known to be extremely harsh compared to the normal ambient conditions onshore. Oil, gas and seawater exposure, high pressure⁸, varying temperatures⁹, different loads/forces, sand/dirt and possible presence of corrosive fluids/gases (like H₂S, chlorides, low pH etc.) are just some of the parameters that needs to be considered in both the design and material selection process.

4.8.1 Method

The method used for selecting materials is based on the theoretical work presented by Professor Michael F. Ashby, in his own book *Materials Selection in Mechanical Design* [5]. The scientific approach is performed with basis in the physical properties of the materials, the loads applied and the ambient conditions present. The process can normally be executed by utilizing a combination of several different printed charts showing material properties, but it's much more efficient to use the software upon which these charts are based on, *CES EduPack* by Granta Design. By using the software, it's possible to narrow down the number of possible material choices to a minimum. The final choice of material will often depend on several local conditions, like practical experience, cost, availability from suppliers etc. The systematic procedure, like this one, cannot help with this and the decision must be based on the personal knowledge of the designer. This does not mean that the result of the systematic procedure is totally irrelevant. It's always important to possess information about which material is best, even if for some reason it's not chosen [5].

⁸ Pressure up to 1379 bar.

⁹ -20°C to 200°C.

*Design of an expandable junk catcher***4.8.2 Requirements**

Due to the repeated exposure to corrosive fluids and gases, mainly metallic materials are being used for manufacturing of the main body parts of most downhole tools, in addition to some special composites for weight-reducing reasons, while plastic, rubber and elastomers are primary used for sealing purposes. A very common problem in a lot of oil and gas wells, is the presence of H₂S. Hydrogen sulfide (H₂S) is a poisonous, corrosive, flammable and colorless gas, with a characteristic odor of “rotten eggs”. It often results from the microbial breakdown of organic matter in the absence of oxygen gas (anaerobe digestion), such as swamps and sewers. The occurrence is most common in volcanic and natural gases (sour gases), but it’s also sometimes present in produced water at certain geographical areas [24].

The biggest danger concerned with materials being exposed to this chemical compound is, that it can lead to rapid and extensive damage to especially concrete and metals used in applications where contact between the substances occur on a regular basis. Hydrogen sulfide corrosion often results in costly maintenance operations, premature replacement or rehabilitation of equipment and/or components which, under optimal conditions should have kept their structural integrity for a considerably longer period of time. It has previously been documented that the technical lifetime of several components have been reduced with as much as 50 % due to rapid exposure to hydrogen sulfide [25].

Hydrogen sulfide corrosion can occur by two different mechanisms: *acid attack resulting from the biological conversion of hydrogen sulfide gas to sulfuric acid in the presence of moisture and a direct chemical reaction with metals such as copper, iron and silver and hydrogen sulfide gas*. The rate of corrosion is governed by physical properties like the ambient temperature, the quantity of hydrogen sulfide available (the concentration) to be biologically converted into sulfuric acid and the materials inherent resistance to acid attack [25].

Based on this, its demanded that all chosen materials at this stage of the process must meet or exceed the predefined requirements presented in the standards *NORSOK M-001:2014 Material selection* [26] and *NS-EN ISO 15156:2015 Petroleum and natural gas industries - Materials for use in H₂S-containing environments in oil and gas production* [21-23] in order to be considered sufficient for the desired purpose and application. Other demands presented by the customer, environmental conditions regarding specific wells and such is also sought to be met by the defined criteria’s in this process of selection.

Design of an expandable junk catcher

The standard NS-EN ISO15156-1:2015 [21] states the following conditions for qualification of suitable materials for general H₂S service:

The material being qualified shall be described and documented, such that those of its properties likely to affect performance in H₂S-containing media are defined. The tolerances or ranges of properties that can occur within the material shall be described and documented.

Metallurgical properties known to affect performance in H₂S-containing environments include chemical composition, method of manufacture, product form, strength, hardness, amount of cold work¹⁰, heat-treatment condition and microstructure.

Several factors needs to be taken into consideration when searching for materials to be used in applications where H₂S might be present. These include but is not limited to, the metallurgical properties mentioned above in addition to the following [22]:

- *H₂S partial pressure or equivalent concentration in the water phase*
- *Chloride ion concentration in the water phase*
- *Acidity (pH) of the water phase*
- *Presence of sulfur or other oxidants*
- *Exposure to non-production fluids*
- *Exposure temperature*
- *Total tensile stress (applied plus residual)*
- *Exposure time*

The remaining parameters and conditions for performing a qualitative material selection for all developed components are primary based on the design specifications, emphasized in the *Specification sheet* in appendix 1, in addition to the formal requirements mentioned above.

¹⁰ Cold work describes the process of plastically deforming metal under conditions of temperature and strain rate that induce strain hardening, usually, but not necessarily, conducted at room temperature [21].

*Design of an expandable junk catcher***4.8.3 Body**

The body of the junk catcher forms the structural basis for the entire structure and it hence requires special attention with regard to proper material selection. The chosen material needs to be able to withstand the environmental factors mentioned in the design requirements in Table 4, like temperature, pressure, corrosion resistance etc. In addition to the manufacturing (processing) requirements, like shaping, forming, machining etc. The primary objective is to reduce the mass of the body, to provide a reasonable weight for the assembled system.

Table 4 - Design requirements for the body

Design requirements for the body	
Function	Contain debris
Constraint	Corrosion resistant H ₂ S-resistant Service temperature, $T \in [-20^{\circ}\text{C}, 177^{\circ}\text{C}]$ Max. Service pressure $p = 1034$ bar $\text{OD} \leq 3.59$ in. Min. Wall thickness, $t = 2.85$ mm Length, L is specified
Objective	Minimize weight/mass, m
Free variable	Cross-section area, A Choice of material

The geometry of the body is when severely simplified, actually similar to a tie-rod like the one illustrated in Figure 10, [5]. The length L , is specified but the cross-sectional area A is not. The objective is to minimize the mass of the body while still carrying the axial load, F safely.



Figure 10 - Tie rod, subject to tension

The mass of the body is described by the following equation 2, formally known as the objective function,

$$m = AL\rho \quad (2)$$

where A is the cross-section area and ρ is the density of the material. The length L and force F are specified and therefore fixed properties, while the cross-section is free. The mass can be reduced by reducing the cross-section, but there is a constraint. A must be sufficient to carry F , requiring that,

Design of an expandable junk catcher

$$\frac{F}{A} \leq \frac{\sigma_f}{S_f} \quad (3)$$

where σ_f is the failure strength and S_f is the safety factor. The same safety factor is applied to all materials and it therefore does not influence the choice of material. It is therefore neglected in the further calculations. By eliminating A between equation 2 and 3 gives the following relation between the functional constraint F , the geometric constraint L and the material properties in the bracket,

$$m \geq FL \left(\frac{\rho}{\sigma_f} \right) \quad (4)$$

The lightest tie that will carry the load F safely is made of the material which has the lowest value for $\frac{\rho}{\sigma_f}$. It's usual for these types of problem to redefine the fraction to turn it into a maximization problem. By inverting the material properties in equation 4, the first material index may be derived,

$$M1 = \frac{\sigma_f}{\rho} \quad (5)$$

The lightest tie-rod capable of safely carrying the load is the one with the largest value of this index, known as the *specific strength*. A similar derivation is commenced focusing on the stiffness, S of the body instead of the failure strength. From this the second material index may be derived,

$$M2 = \frac{E}{\rho} \quad (6)$$

where E is the Young's modulus. This is known as the *specific stiffness*. By implementing both of these material indices, in addition to all the other constraints mentioned in the design requirements into a material property chart in CES EduPack, the process of selecting proper materials is initiated. First, all physical and durability specifications are set as limits in the analysis and then a specific stiffness-specific strength chart is plotted (see Figure 11). By maximizing the index line with slope = 1, at first 10 possible alternative are given:

- Cast iron, ductile
- Commercially pure titanium
- High carbon steel
- Low carbon steel
- Medium carbon steel
- Nickel
- Nickel-based superalloys
- Nickel-chromium alloys
- Stainless steel
- Titanium alloys

Design of an expandable junk catcher

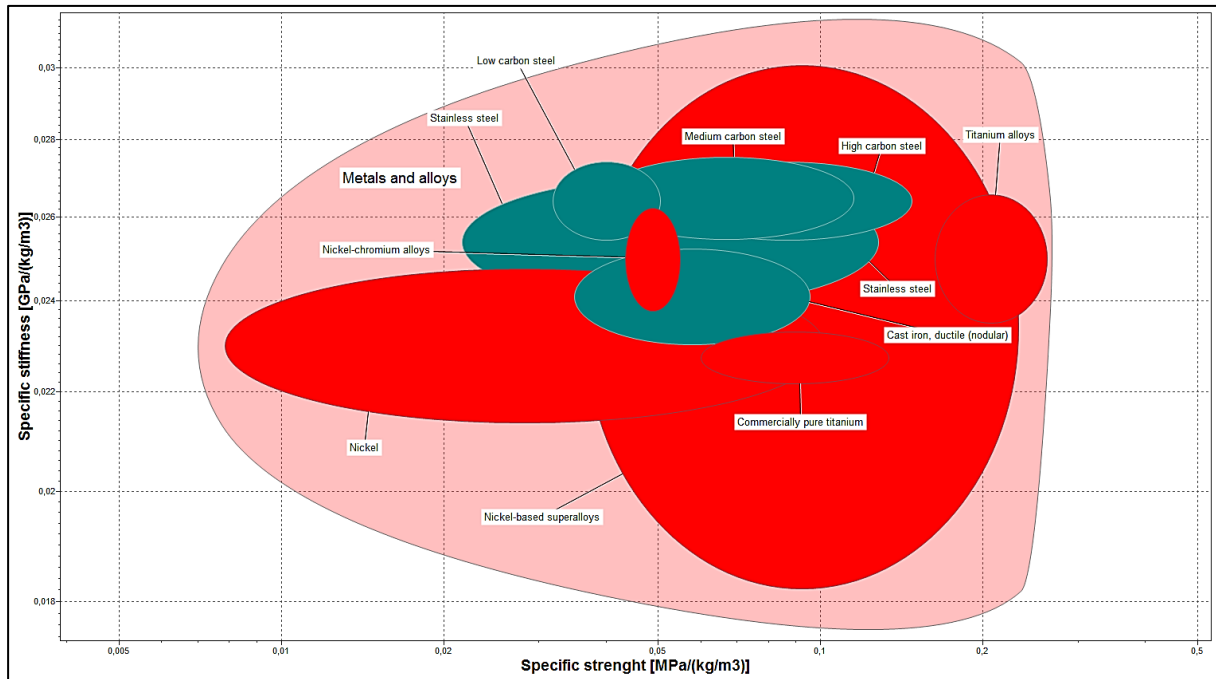

Figure 11 - Specific stiffness-Specific strength chart for the body

This is then reduced to 4 alternatives by maximizing the index, as shown in Figure 12.

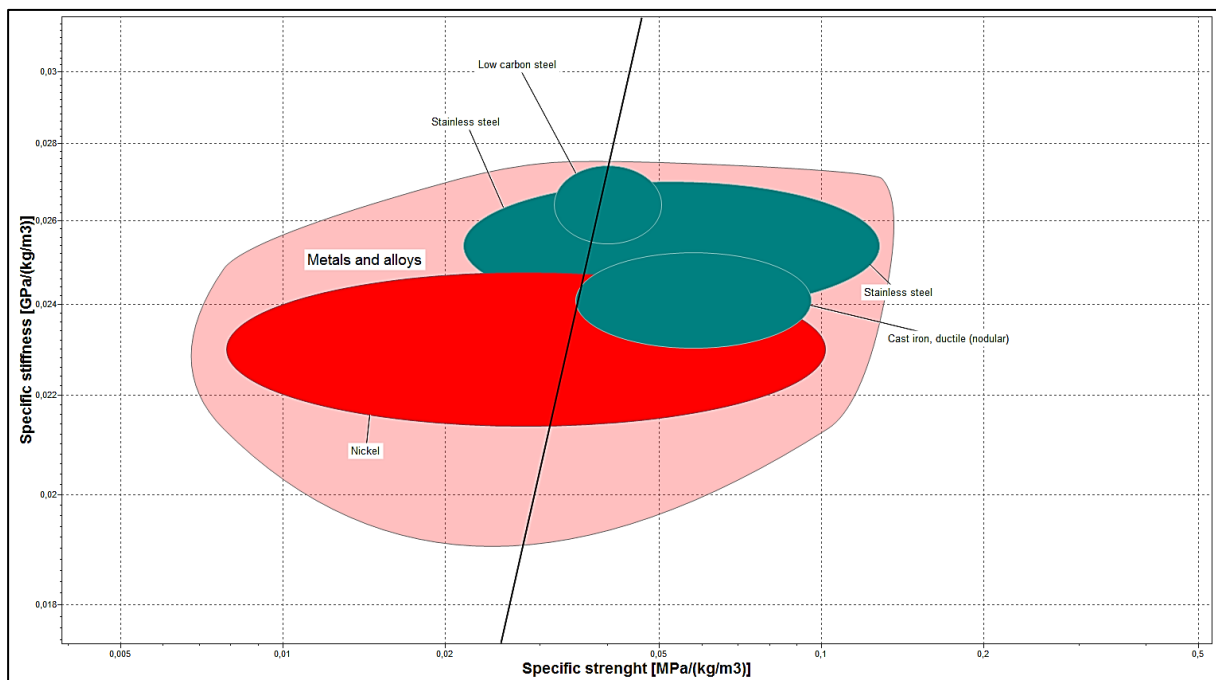

Figure 12 - Specific stiffness-Specific strength chart for the body, maximized with index line

To further reduce this selection cost is taken into consideration, by plotting the price of materials it's possible to further narrow down the selection. The three materials who possesses the best strength and stiffness at low density and the lowest cost per unit is: cast iron (ductile), low carbon steel and stainless steel. All of which are proper material options for manufacturing of the junk catchers body.

Design of an expandable junk catcher

4.8.4 Actuator sleeve

The upper actuator sleeve is supposed to control and perform the activation of the sealing and centralizing mechanisms, in addition to facilitate the connection to the retrieval tool by utilizing the built-in GS fishing neck. Hence, it's extremely important that it is made from a strong material which is able to withstand the forces and impact strengths connected to general retrieval operations under normal conditions.

Table 5 - Design requirements for the actuator sleeve

Design requirements for the actuator sleeve	
Function	Operate mechanism Lead debris into body Connection during retrieval
Constraint	Ability to withstand pulling force Corrosion resistant H ₂ S-resistant Service temperature, T ∈ [-20°C, 177°C] Max. Service pressure p = 1034 bar OD ≤ 3.59 in. ID ≥ 2.17 in. Length, L is specified
Objective	Minimize weight/mass
Free variable	Cross-section area, A Choice of material

The design requirements listed in Table 5 and principal geometry of the actuator sleeve is relatively similar to the one of the body, hence the derivation of material indices and selection of materials is the same. The three materials who possesses the best strength and stiffness qualities at low density and has the lowest cost per unit is: cast iron (ductile), low carbon steel and stainless steel. All of which are proper material options for manufacturing of the actuator sleeve as well.

4.8.5 Seal and cover

The sealing mechanism is consisting of multiple overlapping flaps. The principal geometry of the sealing flaps is shown previously in Figure 8A, it is quite difficult to get a proper representation of the geometry in a simplified manner to perform the derivation of the material indices like in the two previous sections. The flap is a combination of a simply supported hinge-joint and a plate, with design requirements as described in Table 6.

By only implementing the given specifications for the product into CES, ten sufficient alternatives occur, similar to the options first derived from the analysis in section 7.3. By adding in the cost factor (see the cost bar chart in Figure 13) and a desire to use the same material for multiple components, the number of options may be reduced to the four alternatives below:

Design of an expandable junk catcher

- Low carbon steel
- Medium carbon steel
- High carbon steel
- Cast iron, ductile

Table 6 - Design requirements for the seal

Design requirements for the seal	
Function	Seal annulus space around junk catcher body Lead debris into body
Constraint	Ability to seal Corrosion resistant H ₂ S-resistant Service temperature, $T \in [-20^{\circ}\text{C}, 177^{\circ}\text{C}]$ Max. Service pressure $p = 1034 \text{ bar}$
Objective	Minimize weight/mass
Free variable	Choice of material

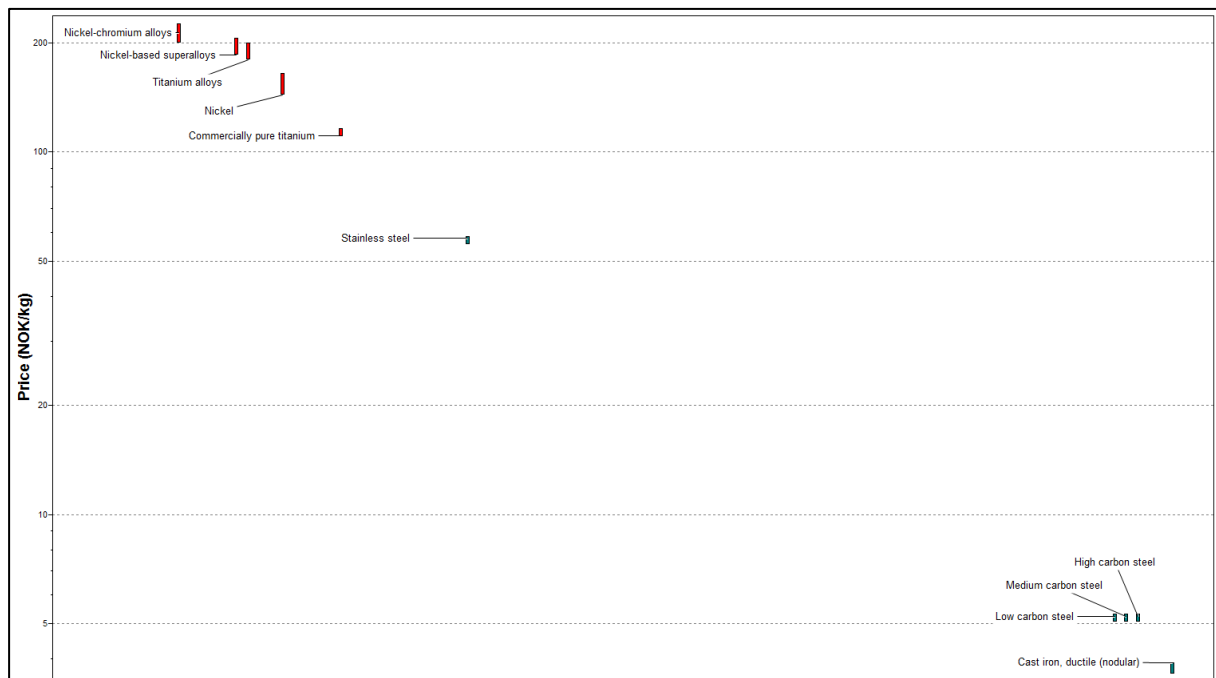

Figure 13 - Cost bar chart

The geometry of the cylindrical flap cover added around the sealing mechanism, as shown in Figure 8B is similar to the geometry of both the body and the actuator sleeve. Hence, the same derivation of indices is applied and the same material alternatives is present.

*Design of an expandable junk catcher***4.8.6 Slips and actuator spring**

The slips are the key components of the centralizing mechanism and hence they need to possess sufficient strength and stiffness to be able to carry the weight of the junk catcher, fully loaded as well as being able to centralize the tool in horizontal position. The design requirements for the slips are given in Table 7.

Table 7 - Design requirements for the slips

Design requirements for the slips	
Function	Centralize junk catcher body Carry total weight of catcher fully loaded
Constraint	Corrosion resistant H ₂ S-resistant Service temperature, T ∈ [-20°C, 177°C] Max. Service pressure p = 1034 bar Length, L is specified
Objective	Minimize weight/mass
Free variable	Cross-section area, A Choice of material

The slip geometry may be simplified into a light stiff beam, considered to be *self-similar*, meaning that all dimensions of the cross-section change in proportion as the size is varied. The slips are loaded in bending over a span of fixed length¹¹ L, with a central load. The stiffness constraint is that it must not deflect more than δ under F, with the objective that the slip should be as light as possible [5]. The mass of the beam is described by the following equation, the objective function,

$$m = AL\rho = b^2L\rho \quad (7)$$

The bending stiffness S of the beam must be at least S*,

$$S = \frac{C_2EI}{L^3} = b^2L\rho \quad (8)$$

where C₂ is a constant related to the support and load condition, which for this case is C₂ = 24 (simply-supported with evenly distributed load) and I is the second moment of area, given by,

$$I = \frac{b^4}{12} = \frac{A^2}{12} \quad (9)$$

¹¹ Assumed for simplification matters, the length between that supports will vary for the real case.

Design of an expandable junk catcher

For a given length L , S^* is adjusted by altering the size of the cross-section. By eliminating b from the objective function, the following relation is obtained,

$$m = \left(\frac{12S^*L^3}{C_2} \right)^{\frac{1}{2}} L \left(\frac{\rho}{E^{\frac{1}{2}}} \right) \quad (10)$$

The quantities S^* , L and C_2 are all specified or constant and the best materials for a light stiff beam are those with the highest values of the material index $M3$. By repeating the operation with a constraint of sufficient strength rather than the stiffness, the second material index $M4$ is derived,

$$M3 = \frac{E^{\frac{1}{2}}}{\rho} \quad \text{and} \quad M4 = \frac{\sigma_f^{\frac{2}{3}}}{\rho} \quad (11)$$

By utilizing the previously stated design specifications as limits and maximizing the material index $M3$ in the specific stiffness-specific strength chart, four different alternatives were located, as shown in Figure 14.

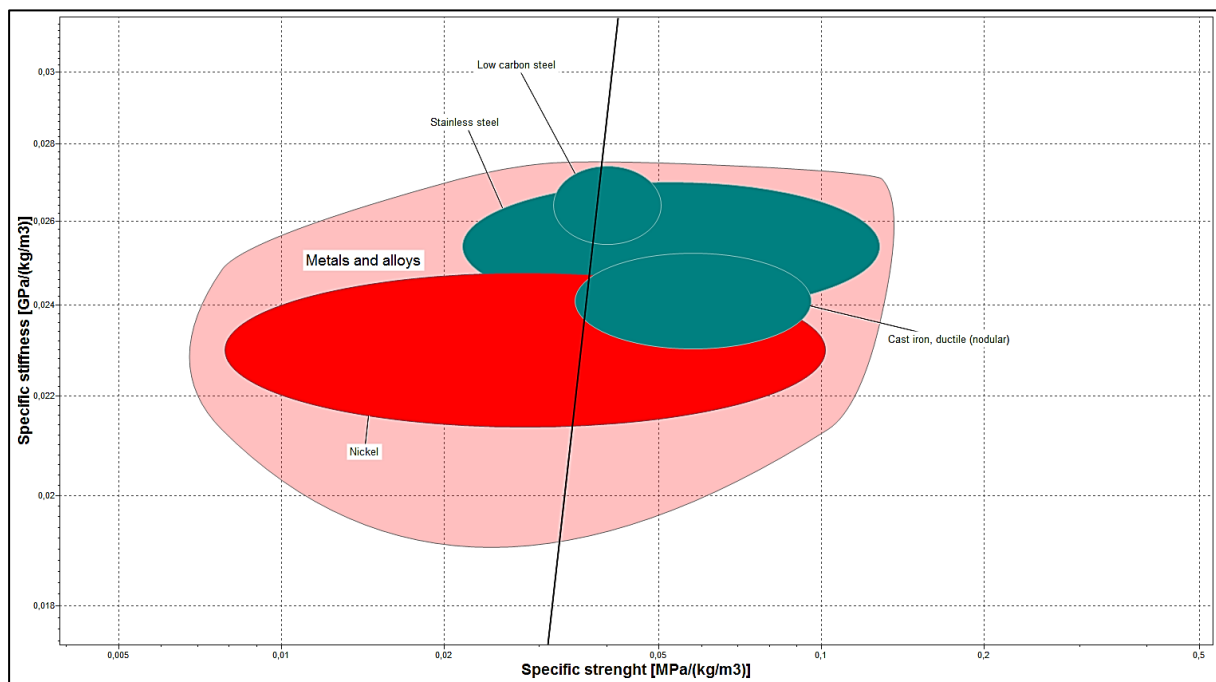

Figure 14 - Specific stiffness-Specific strength chart for the slips, maximized with index line

The materials best suited for manufacturing of the slips is cast iron (ductile), low carbon steel, stainless steel and nickel. By taking cost into consideration, nickel is excluded and three remaining options is suggested. The actuator spring which powers the centralizing mechanism are being bought from an external manufacturer and it is assumed to be manufactured from high grade spring steel.

Design of an expandable junk catcher

5 Result

The primary objective of the project is to develop a new design for an expandable junk catcher, to go with Qinterra's existing line of bridge plugs. The present design is not capable of sealing the annulus space around the catcher and hence forms the key element for the design development. The embodiment described in section 4.7 acts as the overall boundary around the design proposal, which have been modified in several stages and resulted in three versions of the design as described in the following sections. A complete description of the process of design development is covered in the report *Phase II – Design development* (external appendix).

5.1 Version 1

The first version of the fully embodied design is connecting all the aspects stated in the design specification (appendix 1) and the embodiment suggestion (section 3). It consists of a body, a spring-tensioned actuator sleeve with three slips for centralizing purposes and eight flaps for sealing of the annulus space. The seal flaps are protected by a cover, as shown in Figure 15-16. The preliminary design evaluation revealed the following aspect to be considered.

Evaluation:

- + Ability to successfully seal annulus space and centralize body in well tubular
- + Self-activation
- Debris might get caught above seal and restrict collapse



Figure 15 - Concept 1 - Force-Expanded Metal Flaps (FEMF) - Version 1

Design of an expandable junk catcher

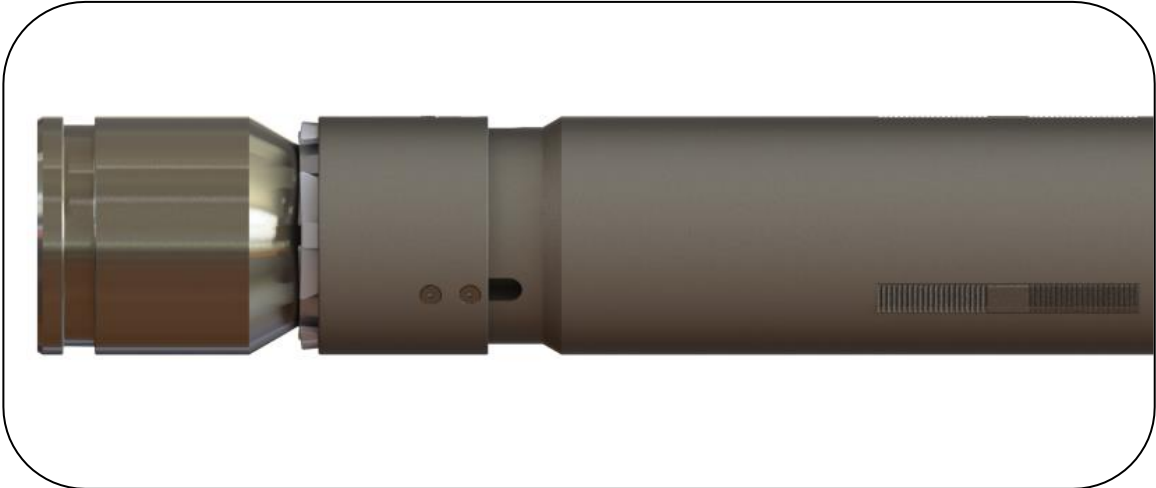

Figure 16 - FEMF - Version 1 - Close up view of the actuator sleeve, seal and centralizing mechanisms

To avoid unwanted activation of the mechanism, spring-tensioned locking pins are added to the bottom of the actuator sleeve, as shown in Figure 17.

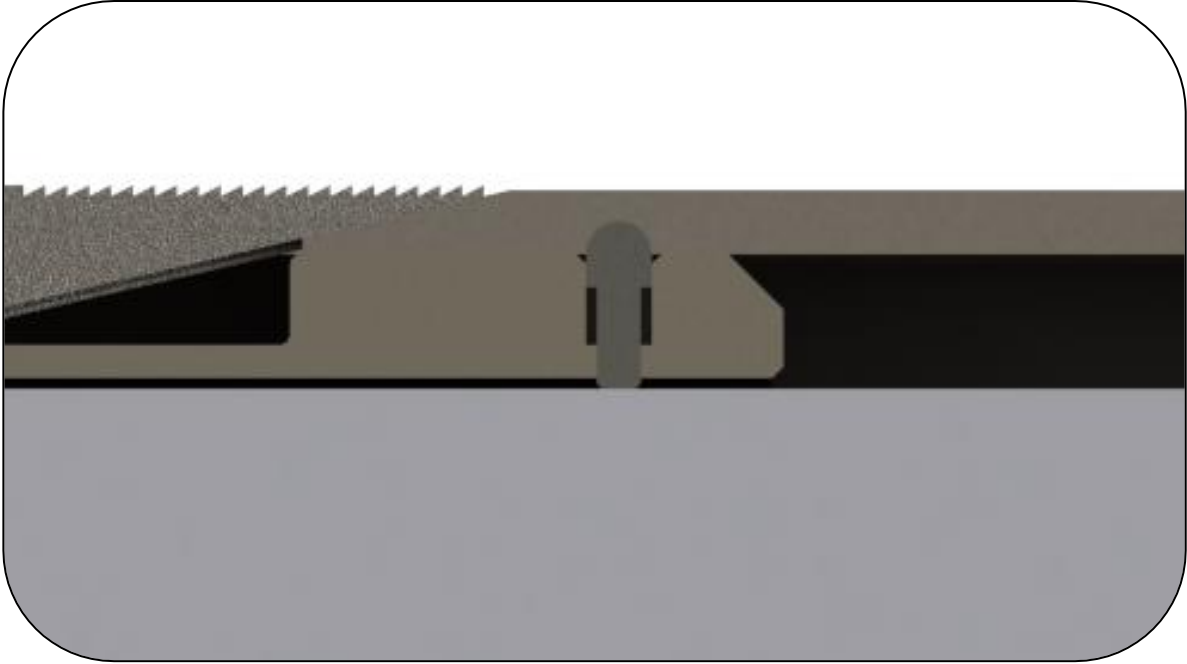

Figure 17 - Locking feature, naturally blocked by the setting tool

*Design of an expandable junk catcher***5.2 Version 2**

Version 1 of the design had a terrible flaw regarding design for manufacturing, the actuator sleeve possessed a geometry which would have made it impossible to assemble the tool in reality. The actuator sleeve was sliced into two pieces and joined together with a threaded connection. The actuator sleeve is assembled by first mounting the locking pins and the slip and mounting bracket sub-assembly and then afterwards move in and tighten up the front end of the sleeve with the threaded section in the face of the rear end. In addition to this, a perforation of the neck of the actuator sleeve was commenced, as one out of several modifications made to version 1. Which all are described in further detail in Table 8.

Evaluation:

- + Less chance of debris being harmful to seal collapse
- + More effective slip design
- + Enhanced reliability for seal cover motion
- Possible debris bypass during seal collapse



Figure 18 - Concept 1 - Force-Expanded Metal Flaps (FEMF) - Version 2

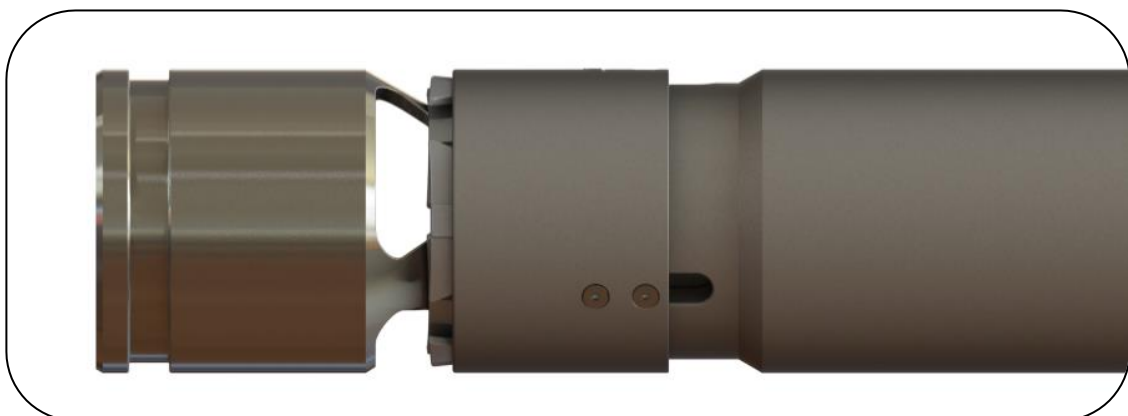

Figure 19 - FEMF - Version 2 - Close up view of the modified actuator sleeve and seal mechanism

Design of an expandable junk catcher

Table 8 - Modifications from version 1

Modifications from Version 1		
Area of modification	Before	After
Add holes to actuator sleeves top and neck.		
Altered slip design, support and implementation of a mounting bracket.	 	 
Countersink spacer block in actuator sleeve body		
Slice of actuator sleeve and implementation of a threaded connection		

*Design of an expandable junk catcher***5.3 Version 3**

Version 3 is the final version and suggested design proposal for a new expandable junk catcher to go with Qinterra's line of modern bridge plugs. The final design is shown in Figure 20. The modifications made to this version, compared to the previous one are all shown schematically in Table 9. The design is combining all the elements desired by Qinterra and fulfills the stated design specification.

The principal geometry of the seal mechanisms expandable flaps is the most important key element in the design proposal. The geometry is revised and improved in version 3, for enhanced reliability, safety and better component fitting (towards body and each other), see Figure 21. However, it might still be a possibility for the flaps to get stuck after being deployed in the well for some time. The installation might be too rough or the rate of corrosion for the casing walls is bigger than expected. It's therefore listed as a suggestion for further work to consider reversing the direction for the seal flaps. In addition to this the support for the flap cover has been revised and reduced in size, to reduce the overall weight of the tool.

Evaluation:

- + Better sealing possibilities
- + Less components
- + Weight reduction
- Flaps might get stuck in well tubular



Figure 20 - Concept 1 - Force-Expanded Metal Flaps (FEMF) - Version 3

Design of an expandable junk catcher

Table 9 - Modifications from version 2





Area of modification	Modifications from Version 2	
	Before	After
Improve flap geometry		
Reduce the size of the spacer block		
Reduce number of fasteners		



Figure 21 - FEMF - Version 3 - Section view of the actuator sleeve, seal and centralizing mechanisms

*Design of an expandable junk catcher***5.4 Structural calculations and analyses (FEA)**

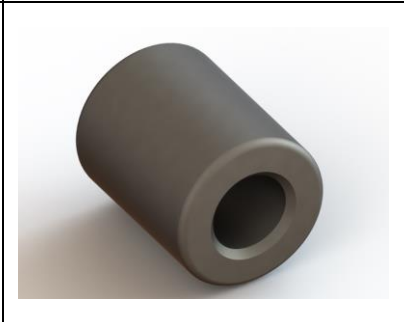
Simplified structural calculations have been performed for all critical components in the developed design. It's very important to detect and map all weak links in the concept as soon as possible, to be able to modify and alter the design features for better and more suitable performance under all possible conditions.

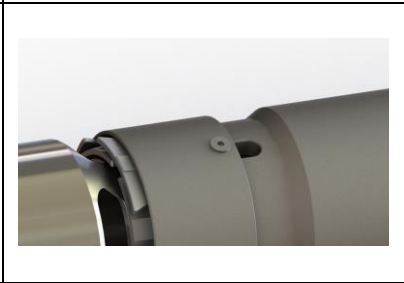
5.4.1 Basis for analyses

The primary objective for all the conducted FE-analyses is to investigate how the external and internal loads within the structure is impacting the exposed parts of the structural design and at the same time verify all the computational results acquired in the previous section, with emphasis on assessing numerically calculated (simulated) stress and deformation against yield strength, requirements and safety factors. All analyses are conducted as static structural analyses in ANSYS Workbench 16.2, with geometry imported directly from SolidWorks. Supports and loads are applied as described for each case.

5.4.2 Actuator spring – Slip mechanism

The activation of the slip mechanism is initiated by the pushing force transferred from the spring, which is being lead across the angle of the slip support in order to be directed perpendicular to the direction of the spring force, as shown in Figure 22.

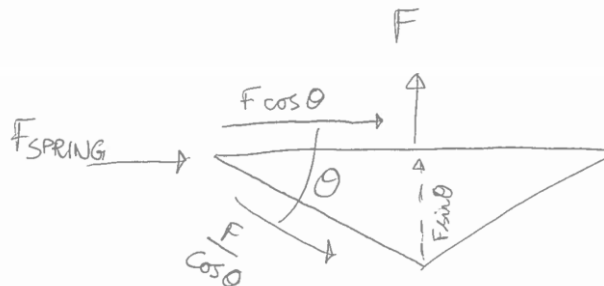

Figure 22 - Spring force distribution

$$F_{Spring} = F \tan \theta = F \left(\frac{\sin \theta}{\cos \theta} \right) \quad (12)$$

The slip angle theta is equal to 13 degrees and the distance travelled for the mechanism $|x|$ is 15 mm. By utilizing the relation below, the spring constant may be derived

$$F_{Spring} = -k \cdot |x| \quad (13)$$

$$F_{Spring} = 980,7 N = -k \cdot |x| \quad (14)$$

$$k = \frac{980,7 [N]}{15 [mm]} = 65,4 \frac{N}{mm} \quad (15)$$

*Design of an expandable junk catcher***5.5 Manufacturing**

The design is based on both manufactured components/parts and parts delivered by other external manufacturers (standardized parts like bolts, springs etc.).

5.6 Cost

Several different factors have an impact on the overall costs for a product development process like this, the fact that it is at this stage only a design proposal, leads to the possibility to discard the costs following this stage at first, based on the relative size of the production (given that this is first considered only a prototype). If you're only going to make one product; small variances in cost wouldn't affect the final price of the product very much. But if you're going to make a million products, then even the slightest difference in cost of the materials would make quite a big difference in your account balance.

The cost of materials have already been briefly considered in the material selection process (see section 4.8). The actual total costs is dependent of a lot of external factors, relatively uncontrollable for the client, like cost of materials, the price and hour consumption at the manufacturers workshop facilities, discounts, serial manufacturing effects etc. The main factors impacting the costs following the present state in this particular project, is shown in the list below.

The main cost contributors following this stage in the development process are:

- Manufacturing of prototype
- Testing and additional analyses of the prototype and documentation of these activities.
- Serial manufacturing of components
- Serial product assembly
- Quality and performance control
- Packing, storage and final shipping to operators location

As stated in the design specification in appendix 1, an upper limit of NOK 75,000 is set as a preliminary limit for materials and manufacturing of the complete expandable junk catcher. Although, a maximum cost limit is set at NOK 150,000, it's desirable to get it down to NOK 50,000.

Design of an expandable junk catcher

6 Evaluation and interpretation

Some possible error sources or drawbacks in connection with the work performed in this project is mentioned below.

6.1 Design evaluation

The design proposal launched as the final design is the third version of the developed concept, by committing several iterations a lot possibilities for modification was discovered during the process. All modifications made to the design has been with the objective to actively enhance reliability, durability and hence improve the safety of the product. The modifications have been thoroughly described in section 5.1-5.3. Regarding the commonly stated question of: *What can go wrong?* A lot of cases have been looked into during the development process.

Unwanted centralization due to the geometry of the slip support is an issue previously known to occur during rough retrieval operations with stuck tools, this is avoided with three different locking systems, actively preventing such an event, as highlighted in Figure 23. The mechanical blocking of both the seal cover and the slip mounting bracket, in addition to re-entering of the locking pins is considered sufficient to discard such issues.

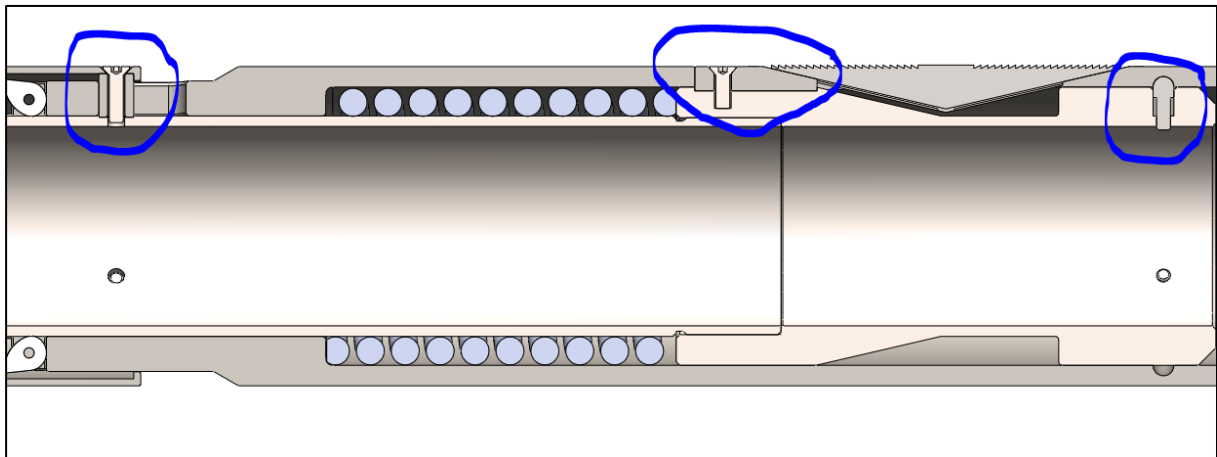
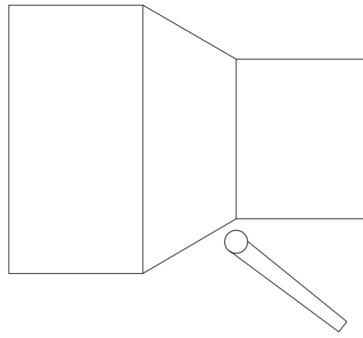

Figure 23 - Natural locking mechanism preventing unwanted centralization during retrieval

Another consideration to be made in regard to the safety-issue is a suggestion to reverse the direction of the flaps, as illustrated in Figure 24. This would further improve the objective stated in the design specification (appendix 1), that the seal and centralizing mechanism is supposed to collapse naturally when being pulled outwards during retrieval operations. Implementation of such a change in the design have not been developed during the process and is hence transferred to section 7.2 Recommendations for further work.

Design of an expandable junk catcher*Figure 24 - Reversed flap direction*

6.2 Approximations in FE-Analyses

The Finite Element Analyses committed in this project have all been simplified and adapted in some form to better fit the mathematical models and systems needed to perform well in the analysis-program. There is always a certain possibility that some of these simplifications have led to possible flaws in the analyses. It's recommended to check and verify all results before they're being used for future development and application. In addition to the other connected recommendations mentioned under section 7.2.

7 Conclusion

The final design concept developed in this project is entirely based on the idea of simplicity, reliability, self-driven all-mechanical operation and a powerful core construction. It has been a key factor throughout the entire process that the tool should be able to handle the most extreme conditions that you can expose it to. It successfully satisfies all the given design specifications and requirements set for such a product. Version 3 of the concept Force-Expanded Metal Flaps is the final version and suggested design proposal for a new expandable junk catcher to go with Qinterra's line of modern bridge plugs.

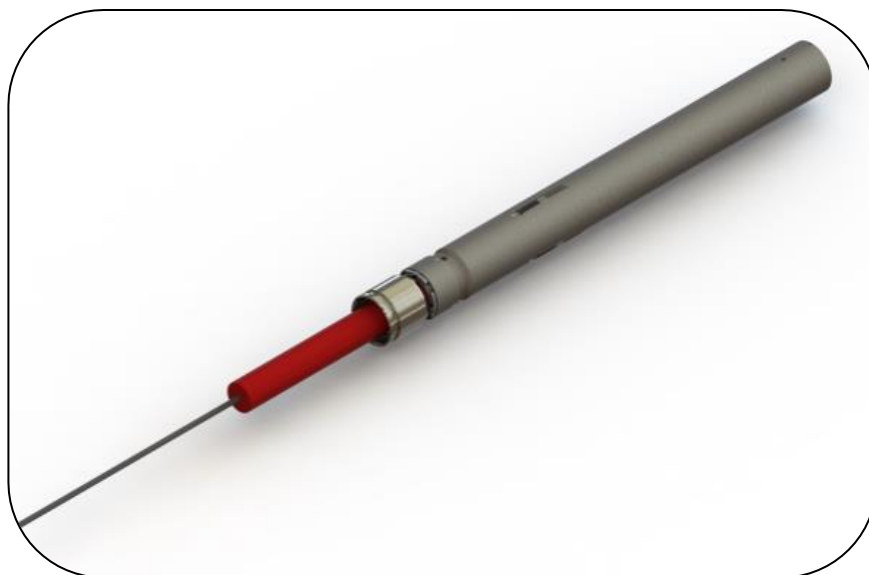
*Figure 25 - Final design proposal - Run in hole-state with setting tool connected*

*Design of an expandable junk catcher***7.1 Material selection**

The choice of material for all the different parts which are going to be manufactured externally are shown in Table 10, below.

Table 10 - Selected materials

Part	Quantity	Material options
Body Slip mounting bracket	1	Cast iron (ductile) Low carbon steel Stainless steel
Actuator sleeve	1	Cast iron (ductile) Low carbon steel Stainless steel
Seal flaps	8	Low carbon steel Medium carbon steel High carbon steel Cast iron, ductile
Flap cover	1	Cast iron (ductile) Low carbon steel Stainless steel
Slips	3	Cast iron (ductile) Low carbon steel Stainless steel
Actuator spring	1	Spring steel

7.2 Recommendations for further work

In the event of a continuation of the project it's recommended to perform the following actions:

- Verify results from the completed structural calculations and perform additional structural calculations on the rest of the structure. There are performed some calculations and simulations on the most important key areas of the final design. But future analysis needs to be executed in order to ensure the highest possible quality and durability.
- Check all the components with Finite Element Analysis to ensure that all the parts/components have sufficient strength.
- Check all components with the aim to investigate the possibility of slimming wall-thicknesses, cross-section thicknesses and such like to prevent the addition of unnecessary weight and waste of materials. A lightweight tool is easier to maneuver and less exhausting for the operator to handle over time, weight reduction will make it more attractive to use.
- Perform selection of tolerances for all passes (bores, pins, axles etc.).

In addition to this, it's recommended to explore the following ideas for possible implementation on the product:

- Reversing the direction of the flap support, motion and expansion, as described in section 6.1.

*Design of an expandable junk catcher***Appendix**

The following documents are attached to this report:

1. Specification sheet
2. Function analysis – Transparent Box Model
3. Morphological chart

The following documents are delivered externally:

- A. Project description
- B. Phase I – Theory, background and design development
- C. Phase II – Design development
- D. SolidWorks files in STEP-format

Software

The specific programs and/or software products utilized in the project work is presented in the table below.

Table 11 - Software

Application	Software
3D-modelling / Computer Aided Design (CAD) / Photo rendering Sketching	SolidWorks 2015 Inkscape AutoCAD 2016
Structural calculations	Mathcad Prime 3.0
Structural analyses / Finite Element Analysis (FEA)	ANSYS Mechanical APDL 16.2 ANSYS Workbench 16.2
Material selection	CES EduPack 2016
Text processing and project management calculations	Microsoft Office 365

*Design of an expandable junk catcher***Figures and tables**Figures:

Figure 1 - Problem area: Plug installed in wellbore (1), accumulation of debris on top of plug (2), rigid junk catcher installed (3), residue from debris is left in critical spaces during retrieval of the work string (4).

Figure 2 - The Rational Method - Overall Model [17]

Figure 3 - Objective tree for design of an expandable junk catcher

Figure 4 - Weighted objective tree

Figure 5 - Junk catcher body

Figure 6 - Actuator sleeve with GS fishneck

Figure 7 - Principal slip geometry

Figure 8 - Seal mechanism - Principal flap geometry (A) and flap cover (B)

Figure 9 - Area covered by expanded flaps

Figure 10 - Tie rod, subject to tension

Figure 11 - Specific stiffness-Specific strength chart for the body

Figure 12 - Specific stiffness-Specific strength chart for the body, maximized with index line

Figure 13 - Cost bar chart

Figure 14 - Specific stiffness-Specific strength chart for the slips, maximized with index line

Figure 15 - Concept 1 - Force-Expanded Metal Flaps (FEMF) - Version 1

Figure 16 - FEMF - Version 1 - Close up view of the actuator sleeve, seal and centralizing mechanisms

Figure 17 - Locking feature, naturally blocked by the setting tool

Figure 18 - Concept 1 - Force-Expanded Metal Flaps (FEMF) - Version 2

Figure 19 - FEMF - Version 2 - Close up view of the modified actuator sleeve and seal mechanism

Figure 20 - Concept 1 - Force-Expanded Metal Flaps (FEMF) - Version 3

Figure 21 - FEMF - Version 3 - Section view of the actuator sleeve, seal and centralizing mechanisms

Figure 22 - Spring force distribution

Figure 22 - Natural locking mechanism preventing unwanted centralization during retrieval

Figure 23 - Reversed flap direction

Figure 25 - Final design proposal - Run in hole-state with setting tool connected

Design of an expandable junk catcher

Tables:

Table 1 - Design requirements and demands provided by the customer

Table 2 - Concept illustrations

Table 3 - Evaluation matrix

Table 4 - Design requirements for the body

Table 5 - Design requirements for the actuator sleeve

Table 6 - Design requirements for the seal

Table 7 - Design requirements for the slips

Table 8 - Modifications from version 1

Table 9 - Modifications from version 2

Table 10 - Selected materials

Table 11 - Software

*Design of an expandable junk catcher***References**

- [1] UiT - The Arctic University of Norway. *SHO6263 Diploma Thesis - M-ID - 30 stp.* 2017 [cited 2016 October 10]; Available from: <https://uit.no/utdanning/emner/emne/479868/sho6263>.
- [2] Standard Norge AS. *NORSOK standards.* 2016 08/07/2016 [cited 2017 February 08]; Available from: <http://www.standard.no/en/sectors/energi-og-klima/petroleum/norsok-standards/#.WJsnm8rJhE>.
- [3] EQT AB. *Qinterra.* 2016 [cited 2017 January 23]; Available from: <https://www.eqt.se/Investments/Current-Portfolio/Qinterra/>.
- [4] Taraldsen, L. *Det kan ta 15 rigger 40 år å plugge alle brønnene på sokkelen.* Teknisk Ukeblad 2014 [cited 2017 January 16]; Available from: <https://www.tu.no/artikler/det-kan-ta-15-rigger-40-ar-a-plugge-alle-bronnene-pa-sokkelen/230974>.
- [5] Ashby, M.F., *Materials Selection in Mechanical Design.* 4 ed. 2011, Oxford: Elsevier Ltd. 646.
- [6] *Webster's encyclopedic unabridged dictionary of the English language.* 1989, New York: Gramercy Books.
- [7] Cambridge Dictionary. *Debris.* 2017 [cited 2017 February 11]; Available from: <http://dictionary.cambridge.org/dictionary/english/debris>.
- [8] Qinterra Technologies. *Collecting tools.* 2014 [cited 2017 February 05]; Available from: <http://www.qinterra.com/products/collecting-tools>.
- [9] Kamal, S., Solberg, Dag Birger, Delot, Quentin, Sønstabø, Gea. *LWI Operation Summary from Tordis K-3 HT3.* 2014; Available from: <http://www.oilfieldsupply.no/news/lwi-operation-summary>.
- [10] Qinterra Technologies. *PrimePlug.* 2017 [cited 2017 March 09]; Available from: <http://www.qinterra.com/uploads/documents/PrimePlug.pdf>.
- [11] Oilenco. *Tubing Anchor Catcher.* 2015 [cited 2017 January 28]; Available from: <http://www.oilenco.com/portfolio/tubing-anchor-catcher/>.
- [12] Oilenco. *Medium Expansion Junk Catcher.* 2015 [cited 2017 January 28]; Available from: <http://www.oilenco.com/portfolio/medium-expansion-junk-catcher/>.
- [13] Oilenco. *High Expansion Junk Catcher.* 2015 [cited 2017 January 28]; Available from: <http://www.oilenco.com/portfolio/high-expansion-junk-catcher/>.
- [14] Interwell Technology AS. *Expandable Junk Catcher (EJC).* 2014 [cited 2017 January 28]; Available from: <http://www.interwell.com/expandable-junk-catcher/category618.html>.
- [15] Interwell Technology AS. *Expandable Junk Catcher Add-on (EJC-A).* 2014 [cited 2017 January 28]; Available from: <http://www.interwell.com/expandable-junk-catcher-add-on/category619.html>.
- [16] Norwegian Oil and Gas Association, *NORSOK D-002:2013 Well intervention equipment.* 2013, Standard Norge AS: Oslo. p. 32.
- [17] Cross, N., *Engineering Design Methods: Strategies for Product Design.* 4 ed. 2008, Chichester: John Wiley & Sons, Ltd. 217.
- [18] Hubka, V. and W.E. Eder, *Principles of engineering design.* 2 ed. Allgemeines Vorgehensmodell des Konstruierens. Vol. 1. 1987, Zürich: Heurista. 118.
- [19] European Committee for Standardization (CEN), *NS-EN ISO 14310:2008 Petroleum and natural gas industries - Downhole equipment - Packers and bridge plugs (ISO 14310:2008).* 2008, Standard Norge AS: Oslo. p. 36.
- [20] American Petroleum Institute, *API Specification 11D1, in Packers and Bridge Plugs* 2015, American Petroleum Institute: Washington, DC. p. 62.

Design of an expandable junk catcher

- [21] European Committee for Standardization (CEN), *NS-EN ISO 15156:2015-1 Petroleum and natural gas industries - Materials for use in H₂S-containing environments in oil and gas production - Part 1: General principles for selection of cracking-resistant materials (ISO 15156-1:2015)*. 2015, Standard Norge AS: Oslo. p. 20.
- [22] European Committee for Standardization (CEN), *NS-EN ISO 15156:2015-2 Petroleum and natural gas industries - Materials for use in H₂S-containing environments in oil and gas production - Part 2: Cracking-resistant carbon and low alloy steels, and the use of cast irons (ISO 15156-2:2015)*. 2015, Standard Norge AS: Oslo. p. 56.
- [23] European Committee for Standardization (CEN), *NS-EN ISO 15156:2015-3 Petroleum and natural gas industries - Materials for use in H₂S-containing environments in oil and gas production - Part 3: Cracking-resistant CRAs (corrosion-resistant alloys) and other alloys (ISO 15156-3:2015)*. 2015, Standard Norge AS: Oslo. p. 96.
- [24] Pedersen, B., *Hydrogensulfid*, in *Store Norske Leksikon*. 2015, Store Norske Leksikon: Oslo.
- [25] United States Environmental Protection Agency (EPA), *Hydrogen Sulfide Corrosion: Its Consequences, Detection and Control*. 1991, EPA: Washington, D.C. p. 19.
- [26] Norwegian Oil and Gas Association, *NORSOK M-001:2014 Materials selection*. 2014, Standard Norge AS: Oslo. p. 32.

*Design of an expandable junk catcher***Appendix 1 – Specification sheet**

Doc. Id. 5.4	SPECIFICATIONS		Qinterra Technologies
Tool/Component	Low-expansion junk catcher		
Date 14.02.17	Edition 3	Revised by KAO	Rev. Date 01.06.17

Specification	Value	Absolute min/max	Desired value
General			
Model	LEJCB 359	-	-
Fits plug	RPH359400	-	-
Use (One time/Multiple)	Multiple times	Min. One time	Multiple times
Casing/Open hole	Preferably used for casing or tubing applications only, use in open-hole wells requires sufficient documentation of all possible restrictions the tool may encounter.		
Casing Size [inch] Range [lb. /ft.]	4.5 11.6-16.9 / 15.5-23.0	Min. 3.688 Min. 11.6	4.5 - 7.0 11.6-16.9 / 29.0-38.0
Plug connection Connection type/size	Specified by Qinterra		
Dimensions [mm]			
Seal not activated:			
OD	91.2 (3.59 in.)	Max. 93.7 (3.69 in.)	91.2 (3.59 in.)
ID	57.0 (2.24 in.)	Min. 55.0 (2.17 in.)	57.0 (2.24 in.)
Length	3000.4 (9.8 ft.)	Max. 3017.5 (9.9 ft.)	1676.4 (5.5 ft.)
Seal activated:			
OD	104.1 (4.10 in.)	Max. 104.1 (4.10 in.)	101.6 (4.00 in.)
ID	57.0 (2.24 in.)	Min. 55.0 (2.17 in.)	57.0 (2.24 in.)
Length	2924.2 (9.6 ft.)	Max. 3017.5 (9.9 ft.)	2438.4 (8.0 ft.)
	Overall length might be subject to changes, depending on area of application.		
Weight [kg]	65.0 (143.3 lb.)	Max. 100.0 (220.5 lb.)	50.0 (110.2 lb.)
Temperature rating [°C]			
Min.	-20 (-4 °F)	-10 (14 °F)	-20 (-4 °F)
Max.	177 (350 °F)	125 (257 °F)	200 (392 °F)
Pressure rating [bar]			
External	1034 (15,000 psi)	1034 (15,000 psi)	1379 (20,000 psi)
Differential	None	None	None
Pressure equalized	Assigned to operate under equalized pressure.		
Load conditions			
<u>Run in hole:</u>			
Vertical	$F_{Axial} = 58.84 \text{ N}$ $F_{Radial} = 0 \text{ N}$	$F_{Axial} = 58.84 \text{ N}$ $F_{Radial} = 0 \text{ N}$	$F_{Axial} = 58.84 \text{ N}$ $F_{Radial} = 0 \text{ N}$
Horizontal	$F_{Axial} = 58.84 \text{ N}$ $F_{Radial} = 1961.3 \text{ N}$	$F_{Axial} = 58.84 \text{ N}$ $F_{Radial} = 1961.3 \text{ N}$	$F_{Axial} = 58.84 \text{ N}$ $F_{Radial} = 1961.3 \text{ N}$

Design of an expandable junk catcher

Setting:			
Vertical	$F_{Axial} = 1961.3 \text{ N}$ $F_{Radial} = 490.3 \text{ N}$	$F_{Axial} = 1961.3 \text{ N}$ $F_{Radial} = 490.3 \text{ N}$	$F_{Axial} = 1961.3 \text{ N}$ $F_{Radial} = 490.3 \text{ N}$
Horizontal	$F_{Axial} = 0 \text{ N}$ $F_{Radial} = 980.7 \text{ N}$	$F_{Axial} = 0 \text{ N}$ $F_{Radial} = 980.7 \text{ N}$	$F_{Axial} = 0 \text{ N}$ $F_{Radial} = 980.7 \text{ N}$
Retrieval:			
Max. push/pull	500 kgf (1102.3 lbf.)	500 kgf (1102.3 lbf.)	500 kgf (1102.3 lbf.)
Vertical	$F_{Axial} = 6.9 \text{ kN}$ $F_{Radial} = 490.3 \text{ N}$	$F_{Axial} = 6.9 \text{ kN}$ $F_{Radial} = 490.3 \text{ N}$	$F_{Axial} = 6.9 \text{ kN}$ $F_{Radial} = 490.3 \text{ N}$
Horizontal	$F_{Axial} = 4.9 \text{ kN}$ $F_{Radial} = 980.7 \text{ N}$	$F_{Axial} = 4.9 \text{ kN}$ $F_{Radial} = 980.7 \text{ N}$	$F_{Axial} = 4.9 \text{ kN}$ $F_{Radial} = 980.7 \text{ N}$
For complete load calculations, see Appendix 4.			
Debris captured Minimum size [mm]	1-2	> 1	2
Storage capacity Internally [litres]	6.5 (1.72 gallons)	> 5.0 (1.32 gallons)	10.0 (2.64 gallons)
Fishing neck Type Size [inch]	GS 4.0	GS Min. 3.0	GS 4.0
Material properties Corrosion resistant H ₂ S-resistant	Yes Yes, up to 2 % concentration		
External power available from setting tool Mechanical Electrical/Optical Hydraulic Pneumatic	Yes (Axial push/pull) No No No	No No No No	Yes Yes Yes Yes
Manufacturing methods	Milling Turning Grinding	Welding Sawing Tapping	Finishing Coating
Safety measures	<p>Emergency operation: Natural collapse of seal and centralization mechanisms when being pulled by GS-tool during retrieval operations.</p> <p>The tool must not get stuck during running, deployment or retrieval from the well!</p>		
Standards Regulations Recommended practices	NS-EN ISO 14310:2008 NORSOK D-002:2013 NS-EN ISO 15156-1:2015	NS-EN ISO 14310:2008	NS-EN ISO 14310:2008 API 11D1 NORSOK D-002:2013 NS-EN ISO 15156-1:2015 NS-EN ISO 15156-2:2015 NS-EN ISO 15156-3:2015
Cost Total cost [NOK]	75 000	Max. 150 000	50 000

Design of an expandable junk catcher



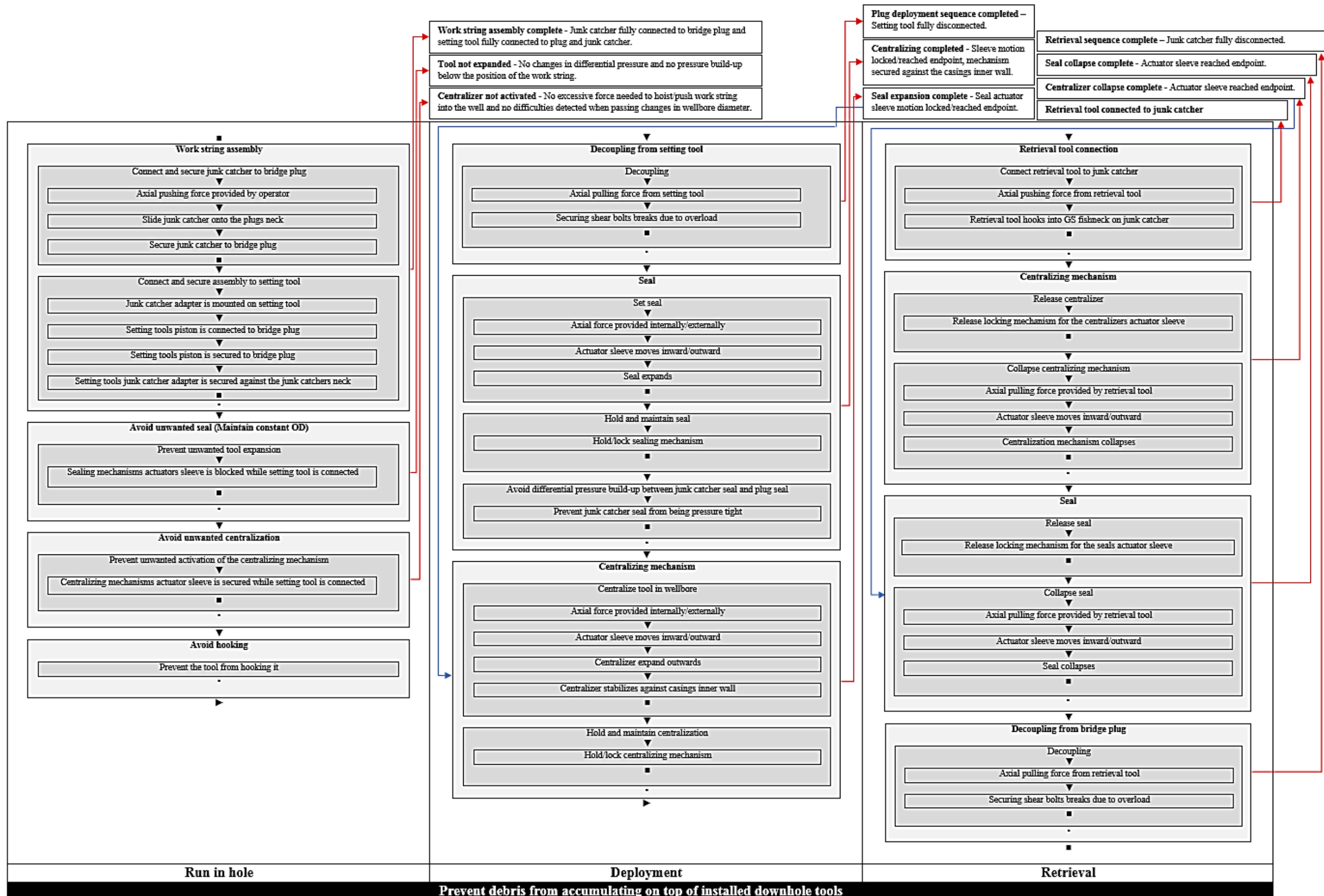



Appendix 2 – Function analysis – Transparent Box Model



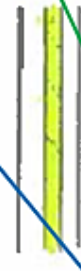

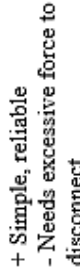

Appendix 3 – Morphological chart

Morphological chart



Solutions Concept 1 – Orange line Concept 2 – Blue line Concept 3 – Green line Concept 4 – Brown line

Function/Operation		Mechanical options			
F – Function	S – Signal	Solution 1	Solution 2	Solution 3	Solution 4
F	Secure junk catcher to bridge plug	<p>Securing shear bolts</p> <p>+ Simple, easy to calculate - Not able to retrieve both plug and catcher in one operation</p> 	<p>High performance adhesive</p> <p>+ Simple - Needs excessive force to disconnect</p> 	<p>Interference fit</p> <p>+ Simple, reliable - Needs excessive force to disconnect</p> 	<p>Spot welds</p> <p>+ Simple assembly - Heat transfer may harm parts and leave "scars" on body</p> 
F	Connection to setting tool	<p>Adapter</p> <p>+ Fits exact - Extra weight</p> 	<p>None</p> <p>+ Simple, reliable - Unstable</p> <p>(No extra connection on top of junk catcher)</p>		
S	Work string assembly complete				
F	Prevent unwanted tool expansion	<p>Actuator motion blocked by setting tool</p> <p>+ Simple - May constrict piston motion</p> 	<p>Lock the junk catcher neck to the JC-adapter</p> <p>+ Reliable - May be difficult to release when fully set</p> 	<p>Spring tensioned locking pins</p> <p>+ Enclosed system - Hard to assemble</p> 	

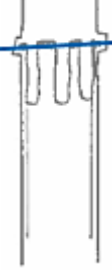
S	Tool not expanded Prevent unwanted activation of the centralizing mechanism	Actuator motion blocked by setting tool + Simple - May constrict piston motion 	Spring tensioned locking pins + Enclosed system - Hard to assemble 		
S	Centralizer not activated Prevent the tool from hooking it	Chamfer edges 30° + Easy to manufacture - Edges still present 	Chamfer edges 45° + Easy to manufacture - Edges still present 	Fillet with radius R on edges + Smooth transitions - Harder to manufacture 	

Deployment						
F	Decoupling from setting tool	Securing shear bolts break due to overload (Existing solution)		Rubber funnel (Internal)	Rubber funnel (External)	Force-expanded metal flaps
S	Plug deployment sequence complete					
F	Seal annulus space	Compressed rubber seal		+ No force needed to seal + Low risk of hooking - Seal-expansion flex wear off with time	+ Improved seal control + "Self-collapse" - Seal-material flex wear off with time	+ Durable, good adaptivity - Increase in part quantity
F	Hold and maintain seal	Flexible locking lip in lower end of actuator sleeve		+ Simple - No physical locking	+ Enclosed system - Hard to assemble and release	+ Simple, self-rotation - Need to control pushed distance
				Actuator sleeve is held in position by a spring	Spring tensioned locking slips which corresponds to an outward facing gap in the actuator sleeve/body	Locking pins, which corresponds to a path in the junk catcher body

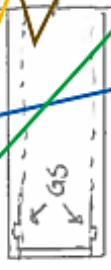
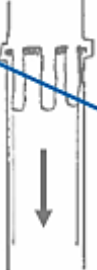
F	Avoid differential pressure build-up between junk catcher seal and plug seal	Gap between seal and casing ID + Simple - Low precision	Ventilation holes in junk catcher body + Reliable - Risk of debris leakage				
S	Seal expansion complete						
F	Centralize tool in wellbore	Flexible bows + Low wear, self-collapsing - Difficult to calculate	Slips + Existing solution - Require outer body movement	Arms without wheels + Only three links/joints - Wear on joint	Arms with wheel in joint + Low impact on casing wall - Wheel hub is a weak link		
F	Hold and maintain centralization	Flexible locking lip in lower end of actuator sleeve + Secure lock - Difficult to release	Actuator sleeve is held in position by a spring + Simple - No physical locking	Spring tensioned locking slips which corresponds to a gap in the actuator sleeve/body + Enclosed system - Hard to assemble	Locking pins, which corresponds to a path in the junk catcher body. + Simple, self-rotation - Need to control pushed distance		
S	Centralizing completed						

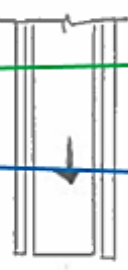
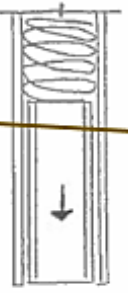
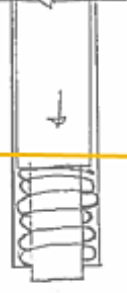
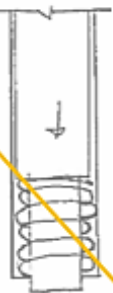
Retrieval				
F	Connect retrieval tool to junk catcher	GS Fishneck + Universal, reliable - Need GS compatible retrieval tool 		
S	Retrieval tool connected to junk catcher			
F	Release centralizer	Pull actuator sleeve with GS retrieval tool until locking lip slips + Simple - Needs excessive force 	Pull actuator sleeve with GS retrieval tool until locking pins break due to overload + Simple - Needs excessive force 	Push actuator sleeve with GS retrieval tool until locking pins enter release path + Simple - Need to control push 
F	Collapse centralizing mechanism	Pull actuator sleeve with GS retrieval tool + Simple, existing method - Stuck sleeve may require excessive force 	Actuator sleeve is pulled with GS retrieval tool and assisted with a spring + Simple - Stuck sleeve may require excessive force 	Pull actuator sleeve with GS retrieval tool until holding spring is fully depressed + Simple, reliable - No physical locking 
S	Centralizer collapse complete			Pull actuator sleeve with GS retrieval tool counter-acting the holding spring + Simple, reliable - Stuck sleeve may require excessive force 

F	Release seal	Pull actuator sleeve with GS retrieval tool until locking lip slips + Simple - Needs excessive force	Pull actuator sleeve with GS retrieval tool until locking pins break due to overload + Simple - Needs excessive force	Push actuator sleeve with GS retrieval tool until locking pins enter release path + Simple - Need to control push	Pull actuator sleeve with GS retrieval tool counter-acting the holding spring + Simple, reliable - Stuck sleeve may require excessive force
F	Collapse seal	Pull actuator sleeve with GS retrieval tool + Simple, existing method - Stuck sleeve may require excessive force	Pull/spring-assisted actuator sleeve with GS retrieval tool + Simple - Stuck sleeve may require excessive force	Pull actuator sleeve with GS retrieval tool until holding spring is fully depressed + Simple, reliable - No physical locking	
S	Seal collapse complete				
F	Decoupling from bridge plug	Securing shear bolts break due to overload + Simple, existing solution - May harm bridge plug	High performance adhesive tear due to overload + Leaves the contact surface relatively unharmed - Needs excessive force	Interference fit slips due to overload + Simple, reliable - Needs excessive force	Spot welds break due to overload + Quick/easy assembly - Hard to calculate
S	Junk catcher fully released				