



## Retroflex Suffixation in Beijing Dialect

*Liu Zhiyin*

*Course code: LIN-3990*

*Master's Degree Programme in Theoretical Linguistics*

*Department of Language and Linguistics*

*Faculty of Humanities, Social Sciences and Education*

*University of Tromsø*

*Spring semester 2012*



# Acknowledgments

I would like to express my sincere gratitude to my supervisor Ove Lorentz, who has provided invaluable advice and inspired me in new methods of solving opacities. Without his elaborative explanation in the class, I will not be engaged in phonology so much. He is always nice and patient to tutor me, although I am not good enough. His insightful suggestion and constant encouragement are printed in my mind. Without his tuition and guidance, this paper will not be shaped. There are no words that I could express to thank him too much.

Second, I would like to thank Martin Krämer, Patrik A.Bye for their delicate lectures in phonology. The lectures are really helpful for me to get a general idea of how to deal with phonological problems. Moreover, I would like to thank the faculty in the department of language and linguistics to offer me a chance in getting close to theoretical linguistics and make me growth. In the end, I would like to thank my friends and my family for supporting me.



# Contents

Acknowledgments	1
Contents	3
<b>1 Introduction</b>	5
1.1. Previous accounts of the retroflex suffixation in phonology	6
<b>2 Phonology Analysis</b>	
---with the retroflex suffix as a consonant	13
2.1. The reconsideration of the underlying forms of the vowels	13
2.2. The phonological transcription of the phonetic data	16
2.3. Feature specification	22
2.4. The Optimality Theory account	40
<b>3 Phonology Analysis</b>	
---with the retroflex suffix as a floating feature	55
3.1. The OT account	55
3.2. The OT-CC introduction	61
3.3. The OT-CC account	63
<b>4 Phonology Analysis</b>	
---with the retroflex suffix as a retroflex vowel	67
4.1. The OT account	67
4.2. The OT-CC account	70
4.3. Feature analysis	79
<b>5 General Conclusion</b>	95
Bibliography	97



# Chapter 1

## Introduction

The aim of this thesis is to explore the phonological opacity of the retroflex suffixation in Beijing Dialect. To be mentioned, I was born in the north of China, never being attached with the languages specified with retroflex suffixation in the end of the words. However, when I moved to Beijing, the oral speaking was filled with retroflex color and some of the words with retroflex feature had a semantic alternation in discourses. After a further approach towards “r-coloring”, I find out that the retroflex suffixation isn't so simple in pronunciation, besides, it is along with the phonological opacity and a series of phonetic variables in adjoining words. Henceforth, the mystery of “r-coloring” is center in this thesis. Since the debates of the underlying form, the phonetic expression and the phonological process of the retroflex suffixation are never terminated, I will commence on varied angles of retroflex suffixation and give a bold assumption about the underlying form.

In the first chapter, I will indicate the former researches about the retroflex suffixation in Beijing dialect, by the time, I will mark on the disadvantages of the former analysis. Then a bold assumption will be proposed, that is, due to the endless arguments of what retroflex suffix is indeed, the retroflex suffix may be an independent consonant, a floating feature attaching to the stem or a monosyllable merging into the main syllable. Given this hypothesis, the following analysis will be cleft as three chapters, one of which is based on the retroflex suffixation as an approximant, another as a floating feature, while the last one taking the retroflex suffixation as a monosyllable. In the second chapter, the basic structure of the syllabification will be reanalyzed in the first instance. After that, I will list the sound inventory of retroflex rhymes according to the Chinese syllabic finals. The retroflex rhymes will be divided into several parts in convenience for the following OT account. Then The classic Optimality Theory (McCarthy&Prince 1993a, Prince&Smolensky 1993) will be adopted ahead of other methods in solving the phonological process. However, the retroflex suffixation goes through a complex phonological procedure, not only a simple ellipsis or epenthesis. The classic OT fails to account for the phonological opacity in Beijing dialect due to its surface-oriented nature. In this paper, I exert means of Local Conjunction (Kager, 1999:392) and Optimality Theory with Candidate Chains (OT-CC). Taken the retroflex suffix as a consonant, I will apply the Parallel Structure of Feature Geometry (Morén, 2003) to account for the feature specification of the vowels and the consonants and then adopt Local conjunction which is proper in solving the feature bindings when the underlying form of the retroflex suffix is a consonant. And OT-CC will be adopted here when the underlying form of the retroflex suffix is a floating feature. OT-CC has the advantage in phonological opacity with a derivation attribution, which the classic OT neglects. And it offers us an intermediate approach, not directly from Inputs to Outputs (McCarthy, 2006, 2007). Furthermore, OT-CC will be advanced in solving the double opacity in r-suffixation when the underlying form of the retroflex suffix is a monosyllable and the PSM feature specification will be adjusted as well to a derivation account of the retroflex suffixation. In the last chapter, I will draw a conclusion about the phenomena of the retroflex suffixation.

### 1.1 Previous Account of The Retroflex Suffixation in phonology

Retroflex suffixation is previously considered as a phenomenon of a syllable being attached with a retroflex suffix, the main syllable becomes retroflexed after a phonological process. Beijing dialect is typical and foremost in the previous studies. Some professors (Wang&He, 1985) have provided significant descriptions about the phonetic alternations of retroflex suffixation. Therefore, it contributes a great deal in the phonological analysis (Cheng,1973; Duanmu, 1990a; Wang, 1993; Ma, 2001) in the future. In the first place, I have listed some examples in Beijing dialect as below,

(a) Stem	R-suffixed	Gloss
ba	ba <sup>r</sup>	<i>handle</i>
tei	tejə <sup>r</sup>	<i>chick</i>
taŋ	tā <sup>r</sup>	<i>candy</i>
gən	gə <sup>r</sup>	<i>root</i>

In the examples above, the retroflex suffix which is affiliated to the stem syllable causes the stem syllable to have a phonetic alternation, and the procedure involves a phonological process. It is worthy of mentioning that [a<sup>r</sup>] has one segment of two moras [aa<sup>r</sup>] with a retroflex suffix in the end. As to other notations such as [a<sub>1</sub>], it has two segments of one vowel and one consonant [a<sub>1</sub>]. A linear approach is firstly brought forward by Cheng (1973), illustrating the retroflex suffixation in a formulated way<sup>®</sup>. Cheng examined the retroflex suffixation under the SPE model<sup>©</sup> (Chomsky&Halle, 1968) and took the retroflex suffixation as a monosyllabic attachment. The underlying form of the retroflex suffixation was posited as /ɤr/, a vowel and a floating r-feature. However, in the succeeding analysis, especially in Lin's (1989:118), we may easily find out, there is no evidence indicating that the mid back vowel /ɤ/ is underlyingly represented in the retroflex suffixation. Besides, the stem syllables will undergo erasing the syllable boundary and deleting the mid back vowel /ɤ/ of the suffix. That is, or rather, denoting /ɤ/ as a redundancy. And it is also equivalent to propose that the underlying form of the retroflex suffixation is /r/. There remains some errors between the underlying form and the surface form in the phonological process.

	Stem	R-suffixed	Surface	Gloss
(b)	teɪɤ	teɪɤ r	[teɪer]	<i>sister</i>
(c)	pɤ	pɤ r	[pər]	<i>cover</i>

In the examples, the surface form of the rhyme part of (b) is [er], however, the surface of the rhyme part of (c) is [ər].

Cheng (1973) proposed that the rule of the application is

$$e \text{----} \rightarrow \text{ə}/C(u)_r$$

<sup>©</sup>SPE: The Sound Pattern of English, invited by Noam Chomsky and Morris Halle in 1968. It transforms an underlying phonemic sequence according to rules and produces as its output the phonetic form that is uttered by a speaker.

<sup>®</sup> Cheng (1973) proposed that there is a language-specific rule for the retroflex suffixation. The rules are Backness rule, Mid vowel laxing rule, Retroflex Suffixation rule, Velar Nasalization rule and Velar Nasal Deletion rule.



However, the plausible explanation is not appropriate, because of a simple reason, that is the false underlying form of the syllabic representation. In (b), the underlying form of [teɪɻ] is /teɪɻ/, but not /teɪɻ/. Therefore, the illustration should be  $teɪɻ+r----->teɪr$  underlyingly. Then the rule of the application by Cheng will be abandoned and the problem remains. Why (b) will finally surface as [teɪr], but (c) will surface as [pəɻ] is still unresolved. Although the rule-based analysis by Cheng can't fully explain the phenomenon of the retroflex suffixation, it opens a window in the phonological field. After realizing the deficiency of the linear approach, a copious amount of scholars turned to load the burden of the rule manipulation. They became to make a concentration on theories of autosegmental phonology and feature geometry. A deeper level of explanations has been integrated for the retroflex suffixation. Yin's analysis (1989) is based on the internal phonological representation. The phonological representation is composed of several independent tiers and the tier is all independent of another where a single phonological alternation will not influence the whole unit. First of all, Yin (1989) assumed the underlying form of the retroflex suffix is /ə/ and she represented it as /r/. A template which was posited with a re-syllabification of the stem and the retroflex segment. The schematics I quoted from Ma's (2001:8) analysis will be adopted here and I will take "pen" and "officeholder" for examples. The analysis is on the basis of two timing slots in onset and two in the rhyme position.

(d) /pi/+r/----->[pɪr] "pen" 笔儿

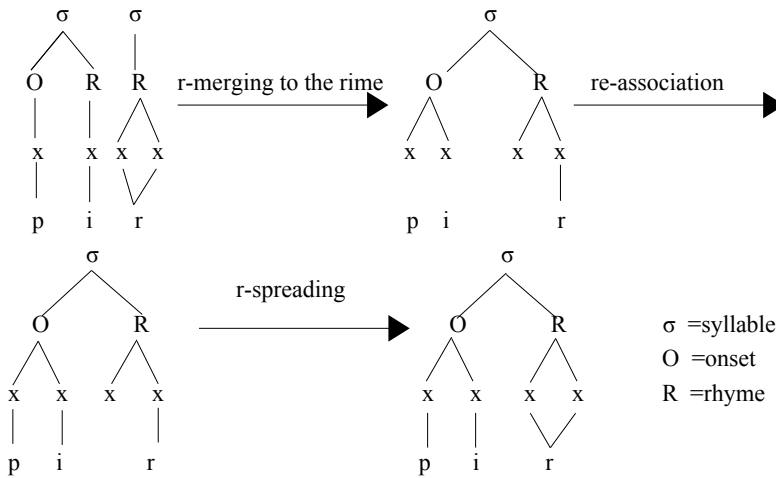

(e) /kuan/+r/----->[kuanr] "officeholder" 官儿

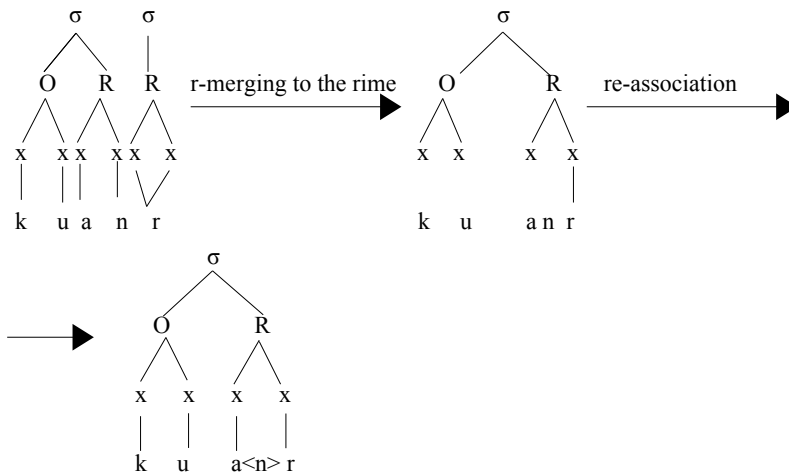

There is no question in the first merging part, however, the part of re-association arouses arguments. Why the suffix is realized as a retroflex liquid when it is attached to one timing of Rhyme, while realized as a mid retroflexed vowel when it is attached to two timings of Rhyme is still arguable. As Ma (2001) has pointed out, the syllabic template is not fixed, take the example of “pen”, the syllable of “pi” has one timing slot of onset and one timing slot of rhyme, but as to the example of “officeholder”, the syllable of “kuan” has two timing slots of onset and two timing slots of Rhyme. Therefore, it will cause the retroflex suffix which is affiliated to the rime to behavior differently. Another non-linear approach with respect to the Chinese segmental phonology is made by Lin (1989). Lin (1989) took the retroflex suffix as a retroflexed liquid which is a segment and proposed that there is a schwa insertion in the retroflexed process. The derivation can be shown as such,

(f)	surface	underlying form	Gloss
	[si]	/s/	“silk” 丝儿
	C	C+C	CVC
	s	s r	s ə r
		CVC	CVC
		s r	s ə r

(g)	[ba]	/ba/	“handle” 把儿
	CV	CV+C	CVC
	b a	b a r	b a r

Lin (1989) has given us a view that in the examples above, in (f), due to that the syllable of “silk” has a unique consonant, the retroflex liquid [r] can't be affiliated with a consonant. Therefore, there must be some epenthesis in between to make the balance of the syllable with a CVC construction. The schwa vowel insertion is appropriate in assignment in (f). As to (g), since there contains a vowel, the retroflex liquid will spontaneously be attached to the rime. The examples above with a segmental analysis may account for how the retroflex being attached to a syllable without nasal consonant ending. Since Chinese contains two types of consonant ending, [n] and [ŋ], therefore, when the retroflex suffix tends to be attached to the rime, instead of having an epenthesis the same as the example (f), there comes a deletion of [n] & [ŋ] and also a nasalization of the vowel in the rhyme position with a velar nasal ending. The proposal by Lin (1989) indicates that there emerges an internal re-association in the main syllable to be propitious to be retroflexed. For instance,

- I) in+r----->iən+r----->iər
- I) aŋ+r----->ãŋ+r----->ãr
- II) iŋ+r----->iãŋ+r----->iãr
- III) uŋ+r----->ũŋ+r----->ũr

As we can see from the examples, the internal re-association occurs in the forepart. The adjustment in the syllabic intern is a preparation for the retroflex suffix to be added. Then the

deletion takes over. The re-association of the main syllable serves for the feature to be fit for the retroflex suffix. As to why the syllable with a velar nasal consonant ending nasalizes the vowel in the retroflexed process, while the syllable with a alveolar nasal consonant ending does not is still ambiguous. Another researcher Duanmu (1990a) attributes the different behavior of /ŋ/ and /n/ ending upon retroflex suffixation to the fact that underlyingly, the nuclear vowel is nasalized with a velar nasal consonant ending, in contrast to the alveolar nasal consonant ending. After adding the retroflex suffix, the vowel with a velar nasal consonant ending maintains the nasality on its own. The solution by Duanmu (1990a) is still under discussion for the reason that the phonetic acoustic experiment reveals the fact that both vowels in front of velar nasal consonants and alveolar consonants have nasalization (Cohn 1990, Piggott 1988). Although the vowel nasalization is not explicit at that time, Duanmu (1990a) posits a fixed syllabic template with three timing slots for all Chinese dialects. The diagram is shown as below,

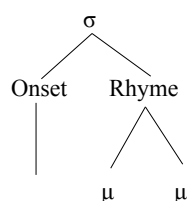

The canonical template describes how the Chinese syllable structure is. Since the canonical representation is CV(C) type, the first C can be linked to the onset position, while V can occupy the first mora of the rhyme. If the syllable has no consonant ending, then the nucleus vowel will spread to the second mora. If there is a consonant ending, the consonant will take another mora position instead. It is also worthy of mentioning, Chinese allows a glide to be on the pre-nucleus position, like this,

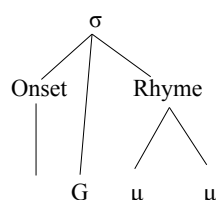

According to Duanmu (1990a), this G is assigned to the onset as a secondary articulation of the C. The glide can be realized as a palatalized or labialized consonant, for instance of [kwa], the velar plosive consonant [k] is linked to the onset, the labialized consonant [w] is assigned to the glide position. The nucleus vowel will occupy the rhyme part with two moras. This canonical template is indicating that first, if the syllable has a CV representation, the vowel is actually lengthened. Second, if the syllable contains a diphthong in the nucleus position, the syllable must be a open syllable without a consonant ending. Furthermore, since there must be a nucleus vowel in the rhyme position, there must be one unique consonant ending. That is no complex coda occurring in Chinese syllables. The template explicitly indicates Chinese syllabification and is helpful in the further studies of the retroflex suffixation. Another deeper proposal by solving the feature match of the retroflex suffix with the ending of the rime, Duanmu (1990a) adopts a feature recycling. The similar adoption is also specified by Wang (1993). The feature geometry is applied, because they believe that the retroflex suffix is derived from the mechanism of feature incorporation (Ma, 2001).

I will take Duanmu (1990a)'s example for illustration.

(h) tau+r<sup>©</sup>-----> ta(u)r-----> ta(u)r----->tar<sup>w</sup>

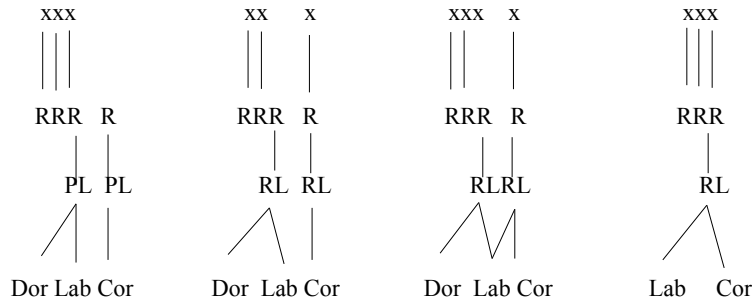

----->t a r<sup>w</sup> [tau] “knife” 刀儿

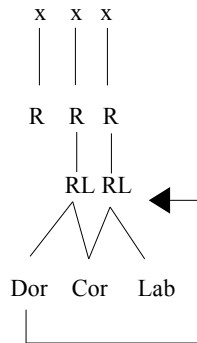

The derivation of “knife” can be shown as above. The /u/ is de-linked from the rime in the first place. After that, /u/ spreads its labial node to the retroflex suffix and the retroflex in return spreads its coronal to /u/. As a consequence of the feature recycling, the /tar<sup>w</sup>/ is realized of having a rounded retroflex ending. That feature addition and feature changing are posited by Wang (1993) further accommodates the [NSL] feature in the feature geometry (Clement1985, Sagay 1986, McCarthy 1988). After analyzing the syncretic of the features in retroflex suffix, Ma (2001) takes the retroflex suffixation into a phonological OT approach. She claims that the retroflex suffix is a diminutive morpheme. According to Ma's (2001) aspects, there concerns an indication of the morphological orientation which in the first place is realized as a [ə̞]. Then through decades, there comes two variable opinions that one insists that the retroflex suffix is still an independent syllable, whereas the other claims that the retroflex suffix has lost its syllabic characteristic and becomes a floating feature. Ma (2001) agrees with the first opinion that the retroflex suffix is a monosyllable for the following reasons,

- I) From the morphological and psychological realization, the retroflex suffix is written and spoken as an independent morpheme in Beijing Dialect.

©In Duanmu's analysis, the retroflex suffix is taken as a diminutive morpheme, shorten for a retroflex vowel and is expressed as [r] instead of [ə̞].

- II) In Chinese Dialects, people take the retroflex suffix as a single morpheme and the retroflex suffix is lexically independent.
- III) The evidence indicates that from a historical point of view, the retroflex suffix lost its syllabicity and merged into the rime.

Given the hypothesis that the retroflex suffix is a monosyllable, Ma (2001) attempts to account the retroflex suffixation with an OT framework. She claims that there is non-distinctive in the representation of /r/ and /ʁ/. However, the inconsistency of the underlying form of the retroflex suffix in the former studies has reached quite a variety of analysis in the further research. Ma (2001) adopts the Sympathy Theory for solving the opacity in the retroflexed process. However, there consists of an argument that whether the constraint she proposes is universally acknowledged and accepted. The constraint is  $*r/C \gg *r/I \gg *r/E \gg *r/A \gg *r/U$ . The constraint is standing for how susceptible the retroflex suffix is against some segments. That the retroflex suffix is not compatible with a consonantal segment highly ranks over a front high vowel, a front mid vowel, a front low vowel and a back vowel. The constraint hierarchy lacks of the empirical evidence and a prove. Although Ma (2001)'s theory is not flawless, she breaks the stone of the opacity in the retroflex suffixation. So far, we can see that there consists of several issues that never reach to an agreement.

- I) The underlying form of the retroflex suffix( including whether it is a consonant, a monosyllable or a feature) and the underlying forms of the monothongs and diphthongs.
- I) The re-syllabification of the words.
- II) The nasalization of the nucleus vowel in the rime after being retroflexed, when the rime has a /ŋ/ ending, in contrast to a /n/ ending.

The former analysis gives more concentration on the first two issues. As to the third problem, J.Zhang (2000) has offered us an acoustic account in whether there is a significant differ in the the two nasal consonants and whether the vowels in front of the nasal consonants are nasalized. The acoustic experiments depends on the perceptual differences of the two nasal consonants. First of all, he hypothesizes that the vowel has a longer nasalized airflow duration in [CVŋ] than in [CVn] and then with the help of a phonetic laboratory and ANOVA®, the hypothesis with a t-test is approved to be correct. To express the difference, J.Zhang (2000) emphasis [CVŋ] as [C $\tilde{V}$ ŋ] and [CVn] as [C $\tilde{V}$ n]. In his analysis, there is a contrast effect in the nasalization. The schematic is as below,

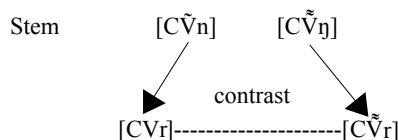

®ANOVA—in statistics, Analysis of Variance. This is a collection of statistical models, and their associated procedures, in which the observed variance in a particular variable is partitioned into components attributable to different sources of variation. And the t-test is for scaling whether there is a significant value.

He maintains that there is a dispersion effect (Flemming 1995). He maintains that the syllable with the alveolar nasal consonant lost its nasalized vowel feature due to the functional consideration of maintaining a contrast between / C $\tilde{V}$ n +r/ and / C $\tilde{V}$ ŋ +r/. Therefore, the whole diagram is as such,

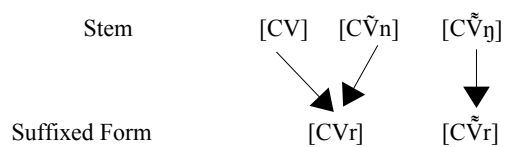

To sum up, the previous studies have gradually disclosed the mystery of the retroflex suffixation. Although there concerns some divergence in what the retroflex suffix is and how the retroflex suffix is attached to the rime, the previous account sheds a light on the further approach towards the retroflex suffixation.

## Chapter 2

# Phonological Analysis

### ---The Analysis with The Underlying Form of the Retroflex Suffix As a consonant

Retroflex suffixation which concerns a series of phonological alternations has aroused quite a divergence in whether the phonological phenomenon is a stem alternation affiliating with a r-feature or a merge of two syllables. The arguments so far have reached three variable analysis, one with an underlying form [ɹ] as a consonantal segment, one with an underlying form [əʔ] as a retroflex vowel and the other as a floating feature. The former researchers, such as Cheng (1973), Yin (1989), Duanmu (1990), Wang (1993), Ma (2001) made different statements on the diachronic evolution of r-suffixation through decades to indicate whether the r-suffix is indeed a segment or a feature. However, it has never reached to an agreement. In Wang Z.J (1993) and Wang J.L (1997)' s paper, they took r-suffix as a floating feature and specified as [+retroflex] at the posterior position. They prefer that the original retroflex suffixation is a procedure of merging two syllables at the beginning, however, with the oral preference, the r-monosyllable graduates into a floating feature attached to the main syllable and loses its own characteristics. Ma (2001) claims that the r-suffix has always existed lexically as an independent entity, in other words, an monosyllabic morpheme, writing as “儿”, phonetically with a rime-dependent feature. Since the underlying form of [ɹ] is directly related to the phonological analysis, an audacious hypothesis is proposed by me. I will assume that all the assumptions about the underlying forms of the retroflex suffix are possible. Hence, there will be three different analysis about the retroflex suffixation with a phonological account. First of all, taken the retroflex suffix as a consonantal segment, there will be a phonetic re-examination of the underlying form of the vowels. Moreover, the segmental structure of the retroflex suffix will be adopted in a general. And I will also give an account for the fusion of the retroflex suffix into the rime through a parallel structure model of feature geometry (Morén, 2003). Second, I will apply different methods to solve the opacity. I will adopt Local Conjunction when the retroflex suffix is a consonant. Since the Classic OT fails to explain the opacity, then I will adopt OT-CC (McCarthy. 2007) for the analysis of opacity when the underlying form of the retroflex suffix is a floating feature or a retroflex vowel. In the end, I will adopt the PSM feature specification again to make a derivation account.

### 2.1. The Reconsideration of The Underlying Forms of The Vowels

In the previous studies, there consists of variable descriptions about the underlying form of the vowels. The numbers of the underlying vowels range from six (Cheng, 1973), to five (R. Cheng 1966), and then to three (Fu, 1980). The surface forms of the vowels in Mandarin can be listed as high vowels [i] [y] [ɿ][ʅ] [u], high mid-vowels [e] [ɤ] [o], mid vowel [ə], mid-low vowels [ɛ] [ʌ] and low vowels [æ] [a] [ɑ] [A]. According to Cheng(1973), the underlying vowels are as below,

i/y	i	u
		ɿ
	A	

In the first place, I will list the surface forms of the vowels in Mandarin, based on L.J.Wang (1991).

	Front	Central	Back
High:	i/y ɿ ʅ		u
Mid-High:	e		ɤ o
Mid:		ə	
Mid-Low:	ɛ		ʌ
Low:	(æ)		
	a		ɑ

There is no further argument about the underlying forms of the high vowels [i] [y] [u]. The phonological representations of the high vowels should be as the same as the phonetic forms. Hence, the underlying forms of the high vowels are /i/ /y/ /u/. There contains two apical vowels, one dental apical vowel [ɿ], which usually occurs after dental sibilants [ts] [tsʰ] [s] and the other retroflex apical vowel [ʅ], which occurs after retroflex sibilants [tʂ] [tʂʰ] [ʂ]. The two apical vowels are prone to follow the sibilants in a contrast to identify the numbers of “fourth”, “fourteen” and “forty”. Cheng’s (1973) postulation which proposed [i̯] as an underlying form of the two apical vowels with an unspecified [back] feature, however, here I propose that [i̯] will be merged in the system of [i], the reason is due to the fact that [i] and [i̯] are in complementary distribution. Therefore, the phoneme can be seen as /i/. As to the mid-high vowels, the mid vowels and mid-low vowels, they can be generally taken as Mid-vowels. They all have the features of [-high, -low]. As to the Mid-vowels [e], [o], [ə], [ɤ], [ɛ], [ʌ], the phonemes can be submitted as a list of /e/, (including [e], [ɛ]), /ə/ (including [ə],[ɤ],[ʌ]) and /o/ (including [o]). But /e/, /o/ and /ə/ are in complimentary distribution as well. They can be taken as /ə/ as an underlying form. The low vowel [a] occurs in front of the alveolar nasal like [n], while the low vowel [ɑ] occurs in front of the velar nasal like [ŋ]. The phoneme of the two low vowels can be /a/ (including [a],[ɑ]). Then we can turn to the diphthongs in Mandarin. In a conventional consideration, people always take Mandarin as a language with rising diphthongs and falling diphthongs (Chao, 1979, Zhu 1980) as I list,

- I) Rising diphthongs: ua uo ia ie ye  
 II) Falling diphthongs: au ou ai ei

The rising diphthongs are the ones with an ending of a non-high vowel, whereas the falling diphthongs are the ones with an ending of a high vowel. However, the phonetic forms are not the actual phonological representations. Duanmu (1990a) and Wang (1993) have proposed that the rising diphthongs are not real diphthongs. The phonological representations can be shown as below,

Phonetic	Representation:	ua	uo	ia	ie	ye
Phonological	Representation:	/wa/	/wə/	/ja/	/jə/	/ɥə/

Thus, we can see that the first vowel in the diphthongs is actually a pre-nucleus glide. The glide parts of the five rising diphthongs can be considered as the syllable onset rather than the vowel in the rhyme parts. The diagram establishes how the phonological representations of the rising diphthongs are as below,



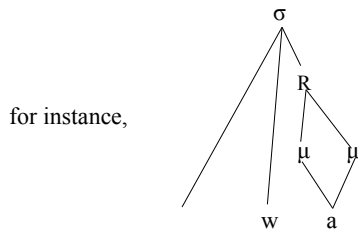

Since the rising diphthongs are not real diphthongs, the question of whether the falling diphthongs are not real diphthongs as well should be reconsidered. Thus, I will adopt an adventurous assumption that the falling diphthongs are not real diphthongs, either. If so, as we know, the diphthongs are not allowed in a closed syllable in Mandarin and the rhyme part has two timing slots. As we can see from the rising diphthongs, the existents of [pian] and [kuan] prove that the underlying representations of them are /pjan/ and /kwan/. If not, there will be a contradicted explanation towards the fact that there are only two timing slots in the rhyme part and the diagram will be puzzled. Thus, the presumption that the rising diphthongs are not real diphthongs is very reasonable. As to the rising diphthongs, that the evidences of \*kain, \*kein, \*koun, \*kaun are non-existed seems to declaim that they may be real diphthongs. However, after re-syllabification when the retroflex consonant is attached to the stem, the final vowel has been deleted. For instance,

phonetic form	consonantal retroflex	phonological form
kai	+ ɿ	-----> kɑɿ
kou	+ ɿ	-----> kəɿ

But if the second vowel is a post-vocalic glide, it will be affected by re-syllabification. Since the real diphthongs are not affected by re-syllabification (Rubach&Booij, 1990), the elimination of the second vowel seems unlikely to be well established. On the other hand, the reason for vocalic segments in the coda position to be omitted has a tendency of avoiding consonants clusters. If the second vowel in the falling diphthongs is a glide, it can be in the second timing slot in the rhyme part. When the consonantal retroflex suffix /ɿ/ is fused into the rime, in the coda position, there will be a consonantal cluster. In order to prevent from the consonantal cluster, the final post vowel glide will be omitted.

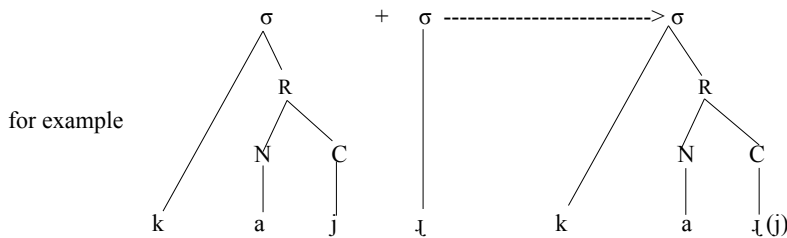

To general the two reasons, the phonological representations of the falling diphthongs are brought up as a combination of a nuclear vowel and a post-nuclear glide.

® when the /i/, /y/ and /u/ are in the position of pre-nuclear, or rather, in front of vowels as glides, they appear as /j/, /ɥ/ and /w/.

And from the retroflex suffixation below, the behaviors of the post-nuclear glides are similar to the final nasals.

/kəw/ + ɿ -----> [kəɿ]  
 /paj/ + ɿ -----> [paj]  
 /paŋ/ + ɿ -----> [pãɿ]  
 /pan/ + ɿ -----> [paj]

The derivation is indicating that the post-vocalic [w] and [j] are deleted when they are attached by the retroflex suffix. They have the same behavior as the [ŋ] and [ɲ] do when being attached by the retroflex suffix. Therefore, if the falling diphthongs are real diphthongs, the vowels will be maintained instead of going through a deletion as the nasal consonants do. The deletion is actually to avoid the consonant clusters in Mandarin in finals. Henceforth, I will claim that the falling diphthongs are not real diphthongs as well. The underlying representations can be like these,

Phonetic	Representation:	au	ou	ai	ei
Phonological	Representation:	/ə/©	/əw/	/aj/	/əj/

## 2.2. The Phonological Transcription of The Phonetic Data

From the previous analysis (L.J.Wang, 1991, L.J.Wang & He, 1985), the documented resources of the data on the retroflex suffixation are all concerning the phonetic description of the stem alternation. As to the phonetic description, the representations of the phonetics mostly vary in whether the representations of the retroflexed rhymes should integrate the retroflex color into the vowel like [paʳ] or just add the retroflex suffix in the end of the latter part of the stem like [paɿ]. Despite the differ of how to represent the phonetics of the stem alternation, the data that the researchers have relied on is mostly based on L.J.Wang (1991). L.J.Wang (1991) have generalized the previous studies including Yin (1989), Lin (1989), Duanmu (1990a) and given us the form © to indicate the stem alternation with phonetic account. Therefore, through the phonetic description, we can transcribe the retroflexed rhyme into the phonological IPA symbols. Then we can find the rules that may stipulate the r- retroflex to be attached to the stem. The phonological forms of the stem rhymes and the retroflexed rhymes are based on Wang (1991:112-127) as followed,

Stem rhyme	retroflexed rhyme	Gloss
Sɿ	səɿ	<i>silk</i>
tʂɿ	tʂəɿ	<i>branch</i>
peɿ	pəɿ	<i>stele</i>
kən	kəɿ	<i>root</i>
kʁ	kɿɿ	<i>song</i>
p <sup>h</sup> o	p <sup>h</sup> oɿ	<i>old women</i>
pa	paj	<i>handle</i>
p <sup>h</sup> ai	p <sup>h</sup> aj	<i>card</i>
pan	paj	<i>plate</i>
tau	tauɿ	<i>knife</i>
kou	kouɿ	<i>hook</i>
kaŋ	kãɿ	<i>jar</i>

© [aj] is an exception in the analysis, since the phonetic form is equal to [ə], but in Mandarin, there is no such phoneme. We just here take it as a less rounded vowel. And the following analysis will neglect it.

©

Kaikouhu			Qichihu			Hekouhu			Cuokouhu			
Gloss	OR	SR	Gloss	OR	SR	Gloss	OR	SR	Gloss	OR	SR	
丝儿 silk	ɿ	ər										
枝儿 branch	ʅ		鸡儿 chicken	i	iər				鱼儿 fish	y	yər	
碑儿 stele	ei					柜儿 cabinet	uei	uər				
根儿 root	ən		今儿 today	in						裙儿 skirt		yn
歌儿 song	ɤ					棍儿 stick	uən					
			街儿 street	ie	ier				月儿 moon	ye	yər	
婆儿 old women	o	or				窝儿 nest	uo	uor				
						屋儿 room	u	ur				
把儿 handle	a	ar	牙儿 tooth	ia	iar	花儿 flower	ua	uar				
牌儿 card	ai					拐儿 crutch	uai					
盘儿 plate	an		尖儿 tine	ian		罐儿 pot	uan			院儿 yard	yan	yar
刀儿 knife	au	aur	票儿 ticket	iao	iaor							
钩儿 hook	ou	our	球儿 ball	iou	iour							
缸儿 jar	aŋ	ār	亮儿 light	iəŋ	iār	筐儿 basket	uaŋ	uār				
灯儿 light	əŋ	ər	影儿 shadow	iŋ	iər	瓮儿 urn	uɔ̄	uər	熊儿 bear	yuŋ	yər	
						空儿 blank	uŋ	ūr				

Stem rhyme	Retroflexed rhyme	Gloss
təŋ	tɕ̥ɿ	<i>light</i>
tɕi	tɕiəɿ	<i>chicken</i>
tɕin	tɕiəɿ	<i>today</i>
tɕiɛ	tɕiɛɿ	<i>street</i>
ia	iəɿ	<i>tooth</i>
tɕian	tɕiəɿ	<i>tine</i>
p <sup>h</sup> iaʊ	p <sup>h</sup> iaʊɿ	<i>ticket</i>
tɕ <sup>h</sup> iou	tɕ <sup>h</sup> iouɿ	<i>ball</i>
liəŋ	liə̃r	<i>light</i>
iŋ	iə̃ɿ	<i>shadow</i>
kuɛi	kuəɿ	<i>cabinet</i>
kuən	kuəɿ	<i>stick</i>
uo	oɿ	<i>nest</i>
u	uɿ	<i>house</i>
hua	huəɿ	<i>flower</i>
kuai	kuəɿ	<i>crutch</i>
kuan	kuəɿ	<i>pot</i>
k <sup>h</sup> uaŋ	k <sup>h</sup> uə̃r	<i>basket</i>
uəŋ	uə̃ɿ	<i>urn</i>
k <sup>h</sup> uŋ	k <sup>h</sup> ũr	<i>blank</i>
y	yəɿ	<i>fish</i>
tɕ <sup>h</sup> yn	tɕ <sup>h</sup> yəɿ	<i>skirt</i>
yɛ	yɛɿ	<i>moon</i>
yan	yəɿ	<i>yard</i>
ɕiuŋ	ɕiūɿ	<i>bear</i>

According to the data which has been phonologically expressed, we can generalize the same patterns in a column and be clear about different stem alternations when retroflex suffix is attached to. In the former studies, Lin (1989:99) has summarized the different stem alternations as below,

- i) The apical vowels will be deleted and there is a schwa insertion coming in.
- ii) Schwa is inserted between the high front vowels [i] [y] and the retroflex consonant, but not between the high back vowel [u] and the retroflex consonant.
- iii) The [i] and [n] endings will be deleted, but [u] ending will be maintained.
- iv) The [ŋ] ending will nasalize the nucleus vowel and then be deleted.
- v) The schwa insertion is happening when the finals are non-low vowels or nasal endings, with an exception of [u] in the final position.

Since I have proposed that the diphthongs are not real diphthongs, the explanation will be modified by me. I will first generalize the possible retroflex rhymes by taking the underlying form of the diphthongs as a nucleus vowel and a glide. Then I will divide the retroflexed behaviors into groups according to the stem alternation. Therefore, we can define why some of the [u] endings will be not deleted and some will be deleted.

## The Generation of the Retroflexed Rhymes in Mandarin in phonological expression

stem plus consonantal ɿ ----->	retroflexed rhymes	Gloss
S	səɿ	<i>silk</i>
tʂ	tʂəɿ	<i>branch</i>
pɛj	pəɿ	<i>stele</i>
kən	kəɿ	<i>root</i>
kɤ	kɤɿ	<i>song</i>
p <sup>h</sup> o	p <sup>h</sup> oɿ	<i>old women</i>
pa	pəɿ	<i>handle</i>
p <sup>h</sup> aj	p <sup>h</sup> ajɿ	<i>card</i>
pan	pənɿ	<i>plate</i>
kow	koɿ	<i>hook</i>
kaŋ	kɑ̃ɿ	<i>jar</i>
təŋ	tɑ̃ɿ	<i>light</i>
tɛi	tɛjəɿ	<i>chicken</i>
tɛin	tɛjəɿ	<i>today</i>
tɛjɛ	tɛjəɿ	<i>street</i>
ja	jəɿ	<i>tooth</i>
tɛjan	tɛjəɿ	<i>tine</i>
p <sup>h</sup> jaw	p <sup>h</sup> jaɿ	<i>ticket</i>
tɛ <sup>h</sup> jow	tɛ <sup>h</sup> joɿ	<i>ball</i>
ljəŋ	ljɑ̃ɿ	<i>light</i>
iŋ	jɿ̃ɿ	<i>shadow</i>
kwɛj	kwəɿ	<i>cabinet</i>
kwən	kwəɿ	<i>stick</i>
wo	wəɿ	<i>nest</i>
u	uɿ	<i>house</i>
hwa	hwəɿ	<i>flower</i>
kwaj	kwəɿ	<i>crutch</i>
kwan	kwəɿ	<i>pot</i>
k <sup>h</sup> waŋ	k <sup>h</sup> wɑ̃ɿ	<i>basket</i>
wəŋ	wɑ̃ɿ	<i>urn</i>
k <sup>h</sup> uŋ	k <sup>h</sup> ũɿ	<i>blank</i>
y	yəɿ	<i>fish</i>
tɛ <sup>h</sup> yn	tɛ <sup>h</sup> yəɿ	<i>skirt</i>
yɛ	yəɿ	<i>moon</i>
yan	yəɿ	<i>yard</i>
ɛiuŋ	ɛiũɿ	<i>bear</i>

Then I will just divide them into groups according to the retroflexed stem alternation. The following findings are listed,

- I) The retroflex suffix is directly attaching to the stem without deleting any segment of the stem.

kɤ+ ɿ -----> kɤɿ  
 p<sup>h</sup>o+ɿ -----> p<sup>h</sup>oɿ  
 pa + ɿ -----> pɑɿ  
 tɛjɛ+ɿ -----> tɛjəɿ  
 ja+ɿ -----> jɑɿ  
 p<sup>h</sup>o+ɿ -----> p<sup>h</sup>oɿ  
 wo+ɿ -----> woɿ  
 u +ɿ -----> uɿ  
 hwa +ɿ -----> hwɑɿ  
 yɛ +ɿ -----> yəɿ

Through the first group in the data, the vowels in the final position which don't have the [+back] feature will recede to the back position. For example, the [a] is retracted to the back position. The vowels who have the [+back] feature will retain the final vowels and the retroflexed consonant will just be added to the main syllable, like [ɤ], [o], [u]. The syllable which has [ɛ] in the ending will be retracted and turn [ɛ] into the retroflex vowel [ə]. Here we can see that the stem with a final vowel will maintain the vowels when the vowels are the back vowels and just add the retroflex consonant. On the other hand, the stem with a final vowel will recede the vowel to the back position and turn to [ɑ] when the vowels are non-back vowels, except the vowel [ɛ].

- II) The final segment of the stem syllable is deleted, when attached with the retroflex suffix.

pej+ ɿ -----> pəɿ  
 kən+ɿ -----> kəɿ  
 p<sup>h</sup>aj +ɿ-----> p<sup>h</sup>ɑɿ  
 pan+ɿ -----> pɑɿ  
 kow+ɿ -----> koɿ  
 tɛjan +ɿ-----> tɛjɑɿ  
 tɛ<sup>h</sup>jow+ɿ-----> tɛ<sup>h</sup>joɿ  
 kwej+ɿ -----> kwəɿ  
 kwən+ɿ -----> kwəɿ  
 kwaj +ɿ-----> kwɑɿ  
 kuan+ɿ -----> kuɑɿ  
 yan +ɿ -----> yɑɿ

The first procedure about the retroflexed suffixation in the second group is to lose the final consonant to avoid the consonantal clusters, and then the non-back vowels will recede to the back position to alter themselves into back vowels. If the vowels are back vowels, they will maintain the back vowels when the retroflex suffix is attaching. However, there is an exception that when the front vowel [e] is retracted to the retroflex vowel [ə].

- III) The final segment of the stem syllable is deleted after nasalizing its preceding vowel, when attached by the retroflex suffix.

kaŋ+ɿ -----> kãɿ  
 təŋ+ɿ -----> tãɿ  
 ljaŋ+ɿ -----> ljãɿ  
 uəŋ+ ɿ-----> wãɿ  
 k<sup>h</sup>waŋ+ɿ-----> k<sup>h</sup>wãɿ  
 k<sup>h</sup>uŋ+ɿ -----> k<sup>h</sup>ũɿ  
 ɕiuŋ+ɿ ----->ɕiũɿ

The stem syllable with a velar nasal consonant ending will first nasalize the preceding vowel in nucleus position and then delete the final consonant. The vowel [a] will be retracted to the back vowel and be nasalized before the deletion of the velar nasal consonant. As to the retroflex vowel [ə] and the back vowel [u], they both will be nasalized before the stem syllable deleting the velar nasal consonant [ŋ]. From the data of the three groups above, we can see that no matter whether we have the deletion and the nasalization or not, the vowels always have the tendency to be in the back position. As to the vowels [e] and [ɛ], they are not retracted to the back position, instead they retracted to be the retroflex vowel.

- IV) There contains an retroflex vowel insertion in the process of the retroflex suffixation to the stem syllable.

S + ɿ----->səɿ  
 tʂ + ɿ ----->tʂəɿ  
 y +ɿ----->yəɿ  
 tɛ<sup>h</sup>yn+ɿ-----> tɛ<sup>h</sup>yəɿ  
 tɕi+ɿ -----> tɕjəɿ  
 tɕin+ɿ -----> tɕjəɿ  
 iŋ+ɿ -----> jãɿ

In the first place, I adopted the proposal of Ma's (2001), the underlying forms of the words "silk" and "branch" are actually omitting the apical vowels [ɿ] and [ɿ], according to the acoustic experiments. Therefore, the retroflex vowel inserts in front of the retroflex consonant. Ignoring the deletion of the final alveolar consonant and the vowel nasalization in the group above, the [i] and [y] will become the pre-nucleus glide and the retroflex vowel is inserted between the pre-nucleus glide and the retroflex consonant [ɿ]. Then a question will be raised. Why the vowels [i] and [y] are not retracted to the back position or get retroflexed, instead, they become the pre-nucleus glides. From the analysis of the previous researches, for example, Wang (1995) proposed that the high front vowel [i] and [y] are not compatible with the retroflex consonant [ɿ] and the two vowels [i] and [y] cannot be retroflexed. Henceforth, from the former studies, it is really hard to make an account for the phenomenon by applying the segmental structure. Instead of applying for the autosegmental phonology, I will just make a re-analysis of the phenomenon with a parallel structure of the feature geometry. I believe that it is the feature reciprocity that determines the alternation of the vowels into glides.

### 2.3. Feature Specification

Despite of the phenomena that the vowels have the tendency of being retracted to the back, we need to see what kind of articulating features of the retroflexed consonant has. The retroflex suffix morpheme will be proposed as a single consonant here. The rhotic consonant exhibits phonetic variation among different languages. The area may range from the alveolar part to the boundary between the hard palate and the velum. In Mandarin, that the under part of the tip and some of the blade of the tongue will reach to the palatal zone. And the tongue dorsum also participates in the retroflex articulation and it retracted the vowel to the back position. The retroflex suffix so far has an involvement of the supralaryngeal and the laryngeal in terms of Feature Geometry (Clement, 1991). The retroflex suffix has the coronal feature of [-anterior, +distributed] and also the dorsal feature [+back]. Then I propose the following structure,

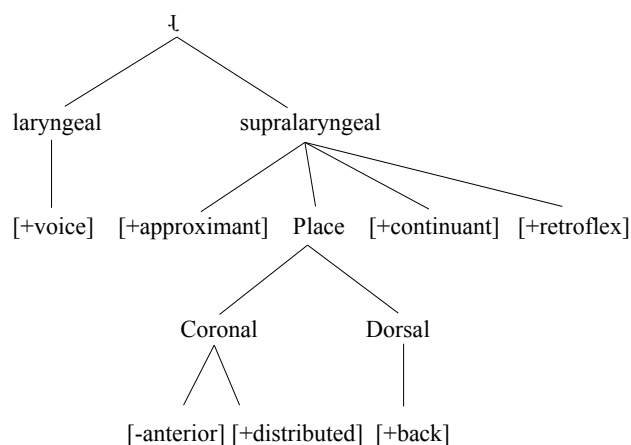

However, Since the Feature Geometry contains a significant number of features to be involved, I will apply to the Parallel Structure of the Feature Geometry (Morén, 2003) to analyze the whole procedure of the retroflex suffixation. The Parallel Structure of Feature Geometry (Morén, 2003) was more advanced in the abundant feature theories and extended from the insights of Clements (1991) to the structural and featural economy. Morén's theory (2003) omits a large number of features, but gives us a new point of view on how to combine the features in a simple way. Instead of applying to plenty of the features, there is a simplified model of feature geometry in segmental representations. The parallel structure is based on the alternation of the two significant features, closed and open of the articulation in manner and coronal and dorsal in place. With Steriade's Aperture Model (1993) of the Relative Openness and Relative Sonority on consonant class and vowel class, it is quoted by Morén (2003),

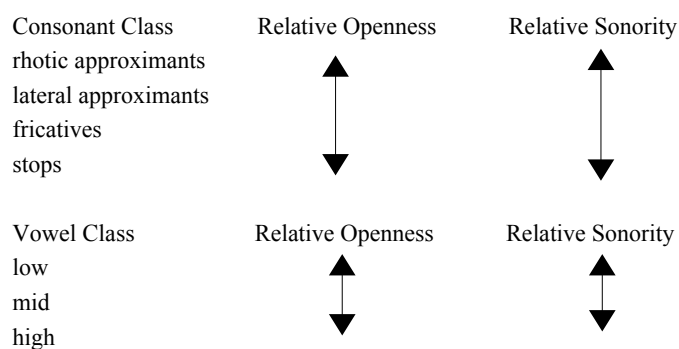



Then the parallel structure (Morén, 2003) is hypothesized with a simplified model with respect to the manners of consonants and vowels. The skeleton is also based on Clements (1995) with the same idea that V-place (manner) is dependent on C-place (manner).

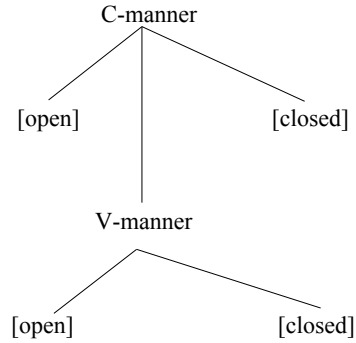

The parallel structure not only solves the problems on how to express the vowels and consonants, but also without counteract the expression of the sonorants. Sonarant consonants can have both a terminal C-manner feature and a terminal V-manner feature (Morén, 2003). Then we can imagine the internal spreading in the way of the parallel structure. The feature spreading from a vowel to another vowel is not blocked in the condition that vowels only have the V-manner and consonants have the C-manner. The diagram quoted from Morén (2003) can be as such,

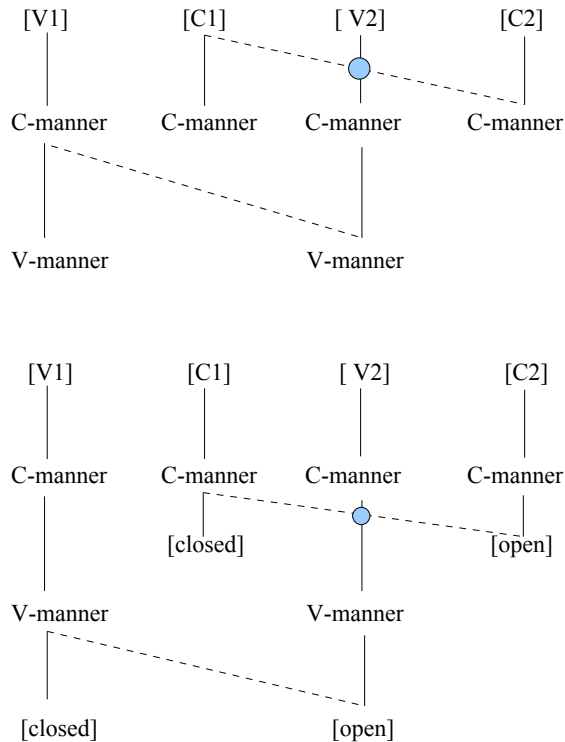

Then when we refer to the parallel structure of the retroflex suffixation, we can find the manner assimilation or nasalization when the retroflex suffix is attaching to the stem syllable. Therefore, I will make a skeleton for illustrating the process and the Parallel Structure Model(PSM) is adopted here for the segment inventory (Morén, 2003). Since the retroflex suffixation is only involved with the rhyme parts of the stem syllable and the retroflex suffix, we can just ignore the features of the onset part of the stem syllable. Thus, I will just concentrate on the features of all the possible vowels, the approximants and consonants, which are the finals.

The phonetic descriptions of the surface vowels

	Front	Central	Back
High:	i/y ʏ ɨ		u
Mid-High:	e		ɤ o (ɔ)
Mid:		ə	
Mid-Low:	ɛ		
Mid-Low:	a		ɑ

Since I have discussed the underlying forms of the phonological representations of the vowels as above, here I propose that [i], [ɨ], [ɨ] have one phoneme, taken as /i/, due to the fact that they are in complementary distribution. In the final endings, we have the high vowels [i][y][u] which have the V-manner [closed]. The phonetics of the high vowels in Mandarin involve the tip of the tongue touching the front of the palate and the root of the teeth. And there is no significant open in the oral cavity. Henceforth, I propose that the high vowels have the vocal manner [closed]. Therefore, the feature of the phoneme /i/ is proposed as below,

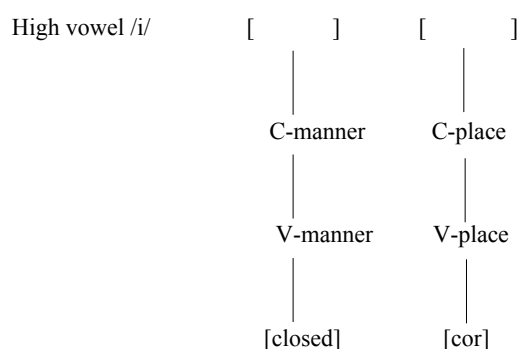

and as to other high vowels, the [y] and [u] have no arguments about the phonemes. Their phonetic forms are their own phonemes /y/, /u/. They both round up the lip with a labial figure. The difference is that for the rounded back vowel [u], the phonetic casts on the round tips and the back of the tongue humping towards the soft palate of the dorsal part, whereas the tongue [y] towards the hard palate of the coronal part. And their features with a PSM structure are like these,

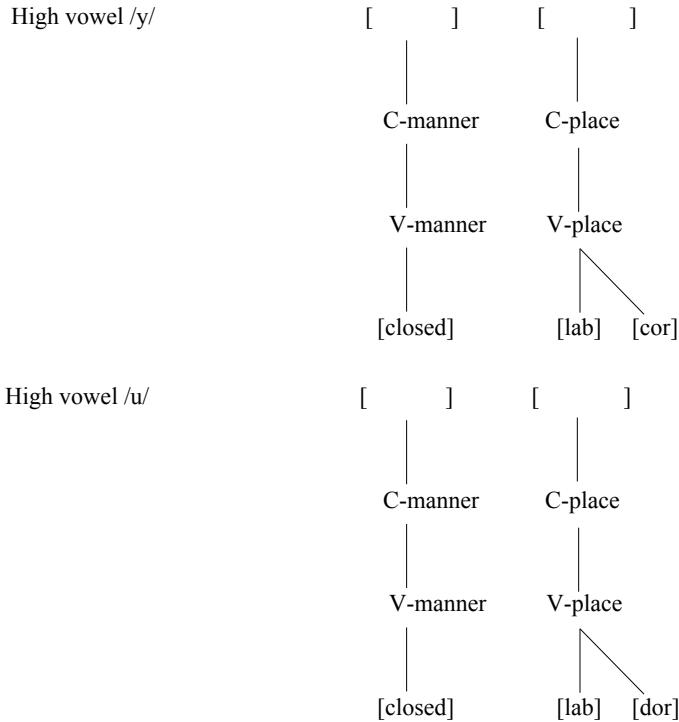

As to the Mid-vowels, the vowels [e], [o] and [ə] are underlyingly [ə], since they are in complementary distribution. The distribution of three vowels is indicating that the three vowels are in a complementary distribution.

e    [ei] [ie] ----- ə    [əi] [iə]  
o    [ou]       ----- ə    [əu]

Here the two vowels [e] and [o] are considered as one phoneme /ə/ with a V-manner of both [closed] and [open]. As we see, Mid-vowels are hard to describe, since “it is impossible to raise the body of the tongue above the the neutral position and simultaneously lower it below that level”(Morén, 2003:235). Therefore, Morén (2003) claims that the simultaneous raising and lowering gestures result in an intermediate position and a vocal tract constriction mid-way between a high and low vowel. Here, the PSM feature of Mid-vowels allots as below,

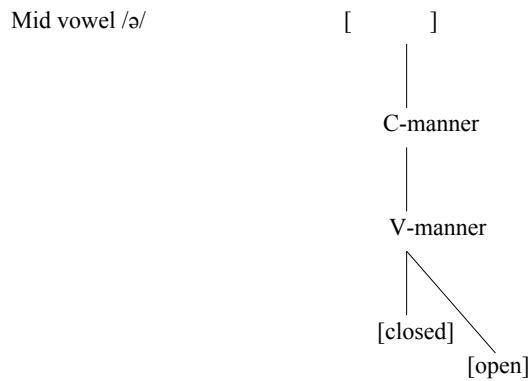

The Mid vowel [ə] which has the V-manner as [closed] and [open], then let's turn to the place features. Since the vowel has different allophones, it can be front and back. Thus, it is underspecified with V-place which can be varied. In general, to the retroflex vowel [ə], for the oral cavity, the tip of the tongue is touching the coronal palate and the root of the tongue is approaching to the dorsal part of the soft palate, which results in half [open] and half [closed]. The PSM model of the vowel [ə] will be as such,

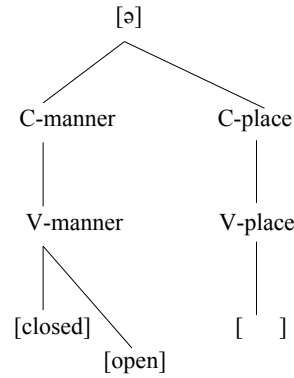

Regarding of the low vowels, the low vowels [a], [ɑ] are always considered to be one phoneme /a/. The front vowel [a] occurs when there is a alveolar nasal ending [n], on the contrary, the back vowel [ɑ] comes up when there is a velar nasal ending [ŋ]. Here in order to pronounce the vowel /a/, the open oral cavity is essential so that the manner includes a [open] feature. Low vowel /a/,

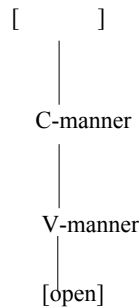

And the phoneme [a] has the allophone of [ɑ], which has a dorsal feature. In this part, the vowel [a] will be underspecified of V-place as well. Since, it can be varied. Thus, the PSM of the low vowel will be as followed,

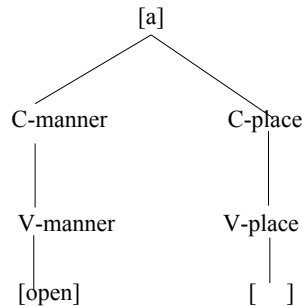

Therefore, I propose that the tableau with a PSM feature specification of the vowels.

			C-manner		V-manner		V-place	
			[closed]	[open]	[closed]	[open]	[Coronal]	[Dorsal]
High vowel	/i/	[i][ɿ] [ɨ]			√		√	
	/u/	[u]			√			√
	/y/	[y]			√		√	
Mid vowel	/ə/	[ɛ][ɛ̃] [ɤ][o][ə]			√	√		
	/a/	[a][ɑ]				√		

Now since the phenomenon concerns only the rhyme part of the syllable, it is sufficient to eliminate the onset consonants and leave the features of the consonants in the coda position to be analyzed. As I have proposed the underlying forms of the diphthongs, the underlying diphthongs consist of [j] and [w] in the final endings. With a conceptual scan, the glides of /j/ and /w/ are the surface forms of the vowels /i/ and /u/. Once they occupy the coda position, they are the allophones of the two vowels. Many alternative proposals argue that in Mandarin there are only two vowels /a/ and /ə/, and /i/, /y/ and /u/ present themselves as /j/, /ɥ/ and /w/. However, here I propose that in the final endings of the diphthongs, /i/ and /u/ are actually /j/ and /w/, whereas in the monothongs, they still remain to be /i/ and /u/. Given the analysis above, /j/ and /w/ have the same feature specification as /i/ and /u/.

glide /j/

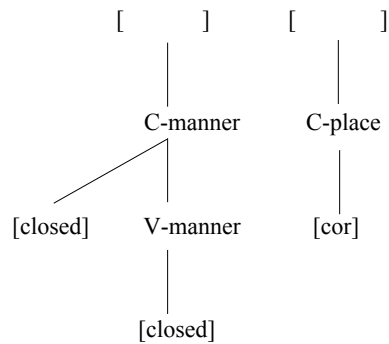

glide /w/

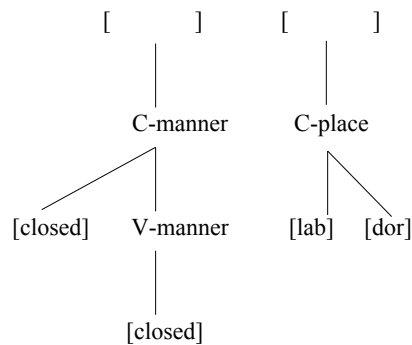

And it remains two consonants not mentioned, one of which is alveolar nasal and the other is velar nasal. For pronouncing the two nasals, the oral cavity closes and the airflow goes through the nasal cavity. The tongue approaches to the coronal palate in the alveolar nasal [n], in contrast, to the dorsal palate in the velar nasal [ŋ]. Therefore, both of nasal consonants have the [nasal] features. Nasals are the topics in the feature geometry in debate and subject to a lot of researches, because of the peculiar figures. The Parallel Structure of Feature Geometry is built on the comparisons between vowels and consonants (Morén, 2003). However, for nasals, they sometimes act like stops and sometimes like sonorant consonants. When /n/ appears in the onset part of a mono-syllable in Mandarin, it always behaviors like a sonorant consonant with an open vocal cavity. Referring to be the final endings, they usually are taken as stops. Then that the postulation of nasality relates to the manner of articulation is adopted here (Morén, 2003).

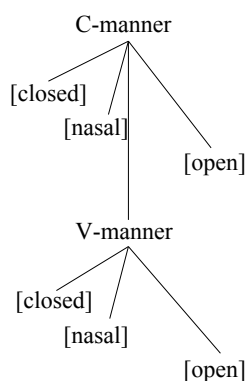

And for the /n/ and /ŋ/ PSM feature geometry,

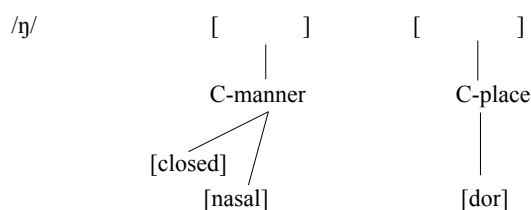
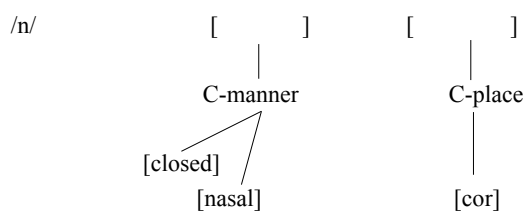

Therefore, the PSM feature specification of the final endings, which are involved in the retroflex suffixation is in the tableau.

			C-manner			V-manner		C-place	
			[closed]	[open]	[nasal]	[closed]	[open]	[Coronal]	[Dorsal]
Stop	/n/	[n]	✓		✓			✓	
	/ŋ/	[ŋ]	✓		✓				✓
approximant	/j/	[j]	✓			✓		✓	
	/w/	[w]	✓			✓			✓

In general, the vowels which have been dispersed among high vowels /i/, /y/, /u/, mid vowel /ə/ and low vowel /a/ in Mandarin. With the feature specification of PSM geometry, they have the V-manner of [open] and [closed], as to the V-place, I propose that they vary in coronal place and dorsal place. Referring to the consonants, the post-vocalic glides which are the allophones of the vowels /i/ and /u/ have the same V-manner as the vowels /i/, /u/ do and C-manner of [closed]. The alveolar nasal and velar nasal both contains a [nasal] feature in the manner, compared with post-vocalic glides. To specify the C-place, the alveolar nasal /n/ has the [cor] feature, while the velar nasal [ŋ] has [dor] feature. Therefore, I will sum it up in one tableau as below,

			C-manner			V-manner		C-place		V-place	
			[closed]	[open]	[nasal]	[closed]	[open]	[Cor]	[Dor]	[Cor]	[Dor]
Stop	/n/	[n]	✓		✓			✓			
	/ŋ/	[ŋ]	✓		✓				✓		
approximant	/j/	[j]	✓			✓		✓			
	/w/	[w]	✓			✓			✓		
High vowel	/i/	[i][ɿ] [ɨ]				✓				✓	
	/y/	[y]				✓				✓	
	/u/	[u]				✓					✓
Mid vowel	[ə]	[e][ɛ] [ɤ][o] [ə]				✓	✓				
Low vowel	/a/	[a][ɑ]					✓				

Since the feature geometry of the retroflex consonant /ɻ/ contains too many features, in order to be shorten, I will analyze the retroflex consonant /ɻ/ with a Parallel Structure of Feature Geometry. The rhotic coda /ɻ/ dispenses the tongue into two parts in Beijing dialect, the tip and the root. With the tip touching the hard palate and the dorsum of the tongue lifting towards the soft palate, the retroflex consonant has both [cor] and [dor] features in C-place, and the retroflex feature is a dependent of posterior coronal, which can be taken as a [retro] feature with the apex of tip attached to posterior coronal. And with opening the mouth and blocking the lateral part of the turbulence, the rhotic /ɻ/ has [open] in C-manner and [closed] in V-manner.

So the tableau is followed,

			C-manner			V-manner		C-place	
			[closed]	[open]	[nasal]	[closed]	[open]	[Coronal]	[Dorsal]
Rhotic /ɹ/	/ɹ/	[ɹ]		✓		✓		✓	✓

Then the PSM feature Geometry for retroflex suffixation,

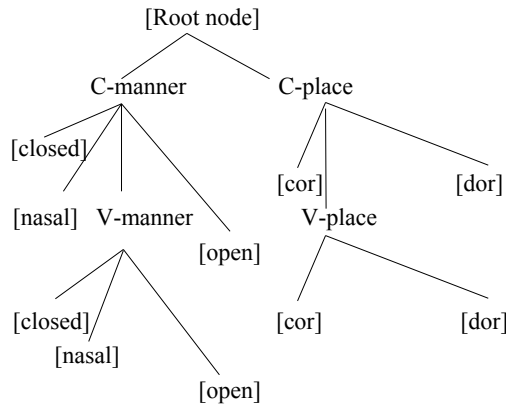

Then we will figure out how the retroflex suffix is attached to the rime with a Parallel Structure of Feature Geometry. Now we turn to the first group which the retroflex suffix is added without deleting any segments in the stem.

- kɹ+ ɹ -----> kɹɹ
- p<sup>h</sup>o+ɹ -----> p<sup>h</sup>oɹ
- pa + ɹ -----> paɹ
- tɛjɛ+ɹ -----> tɛjɛɹ
- ja+ɹ -----> jaɹ
- p<sup>h</sup>o+ɹ -----> p<sup>h</sup>oɹ
- wo+ɹ -----> woɹ
- u +ɹ -----> uɹ
- hwa +ɹ -----> hwaɹ
- yɛ +ɹ -----> yɛɹ

Since we propose the retroflex vowel is the underlying phoneme of mid vowels, due to that /ə/ is in a complementary distribution with other mid vowels. The data with a phonological representation can be summarized as

- /ə/ +/ɹ/ ----->[əɹ]
- /a/+ɹ/ ----->[aɹ]©
- /u/ +/ɹ/ ----->[uɹ]

Then we apply PSM feature geometry to see how the retroflex /ɹ/ fuses into the endings of vowels in the stem.

©Here the vowel [a] and [a] are allophones, it is just for indicating that [a] is a back vowel with a dorsal feature.



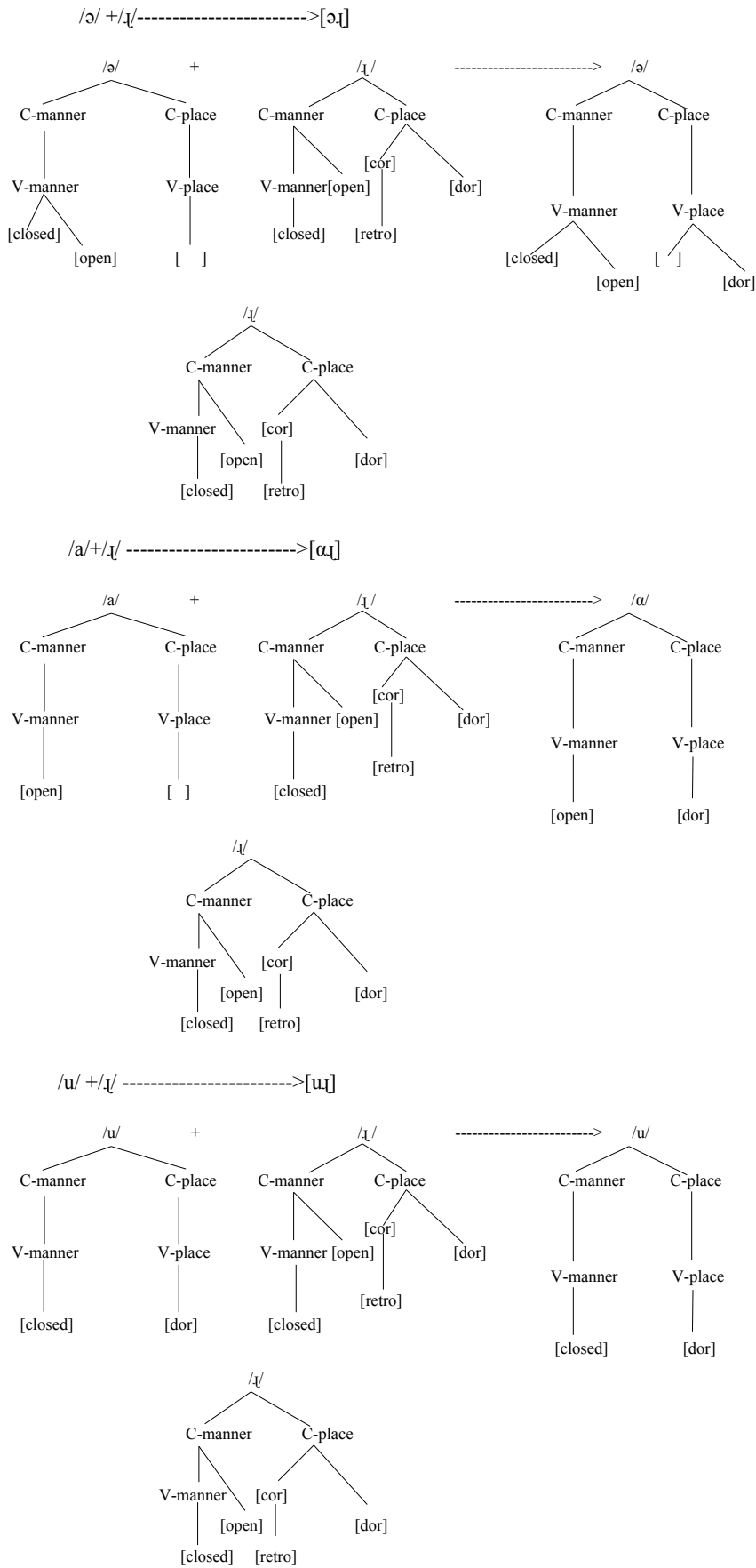

As we can see, in the first group, no matter how variable the vowels are in the V-manner features, the retroflex consonant /ɻ/ tries to assimilate the vowels in place so that all the vowels will retract to the back and be compatible with the dorsal feature of the retroflex consonant. The allophone vowels of the retroflex vowel such as [o], [ɤ] match the assimilation and the dorsal feature remains. As to the allophone of [ɛ], it assimilates the dorsal feature of the retroflex consonant as well. And it adds a [cor] feature as well and becomes a retroflex vowel. Therefore, I underspecify the [cor] feature in the phoneme of [ə]. As to the [retro] feature in the coronal, since the retroflex consonant is one segment in the syllable, the retroflex feature remains the same place in the retroflex consonant.

In the second group,

- pej+ɻ -----> pəɻ
- kən+ɻ -----> kəɻ
- p<sup>h</sup>aj+ɻ-----> p<sup>h</sup>əɻ
- pan+ɻ -----> pəɻ
- kow+ɻ -----> koɻ
- təjan+ɻ-----> tɛjəɻ
- te<sup>h</sup>jow+ɻ-----> te<sup>h</sup>jəɻ
- kwej+ɻ -----> kwəɻ
- kwən+ɻ -----> kwəɻ
- kwaj+ɻ-----> kwəɻ
- kuan+ɻ -----> kuəɻ
- yan+ɻ -----> yəɻ

The phoneme takes the place of the surface vowel and the summary of the second group is as followed,

- /əj/+ /ɻ/ -----> [əɻ]
- /ən/+ /ɻ/ -----> [əɻ]
- /əw/+ /ɻ/ -----> [əɻ]
- /an/+ /ɻ/ -----> [əɻ]
- /aj/+ /ɻ/ -----> [əɻ]

It seems that with a deletion of the final consonant, including /j/, /w/ and /n/, the retroflex suffix /ɻ/ assimilates the vowels in place. If the vowel doesn't have a [dor] feature, it will be assimilated to recede to the back by the retroflex suffix. And the [retro] feature remains in the retroflex consonant.

The skeletons are as below,

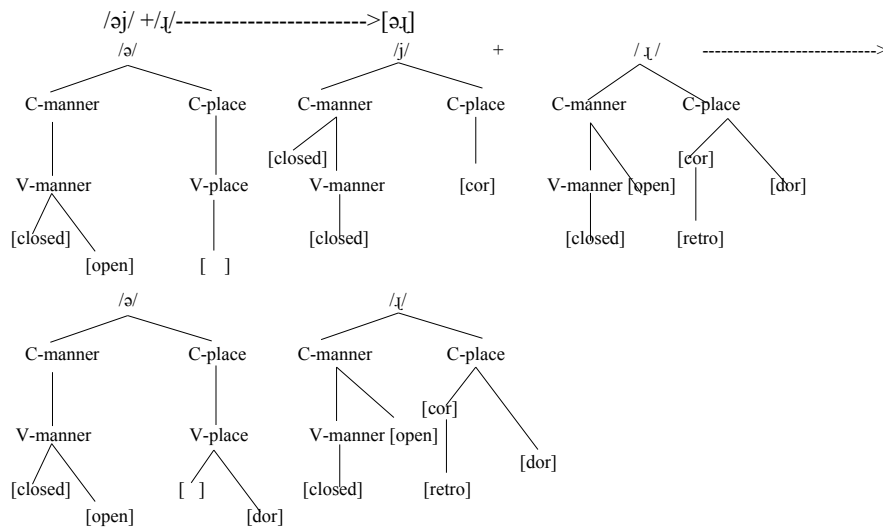

/ən/+ /ɪ/ -----> [əɪ]

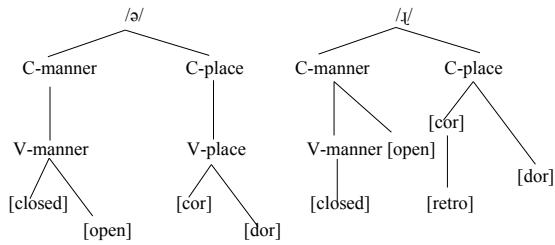
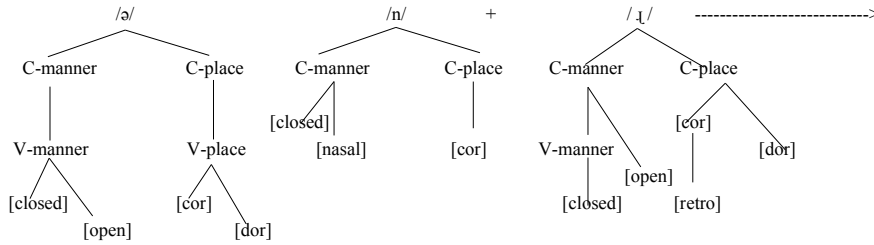

/əw/+ /ɪ/ -----> [əɪ]

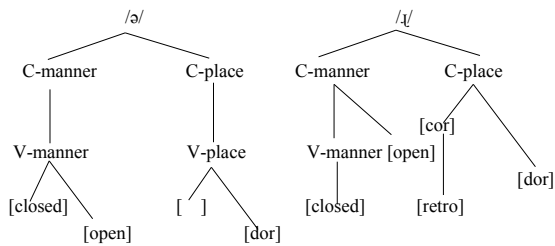
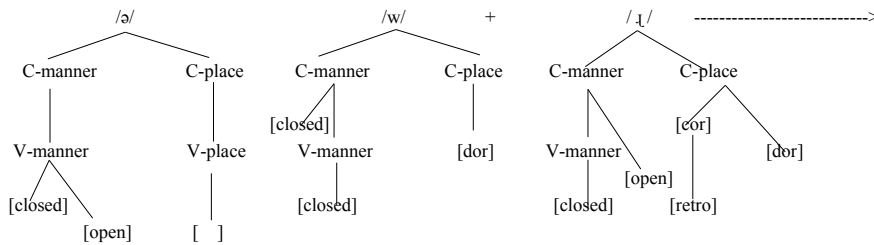

/an/+ /ɪ/ -----> [aɪ]

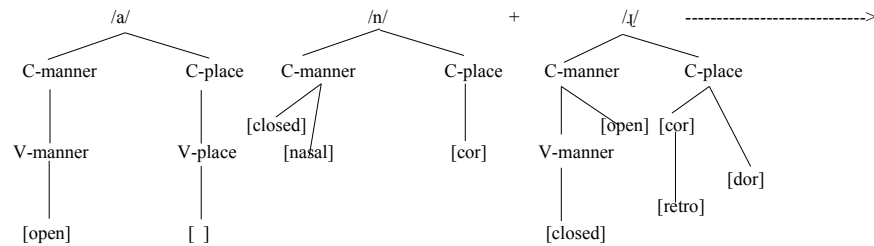

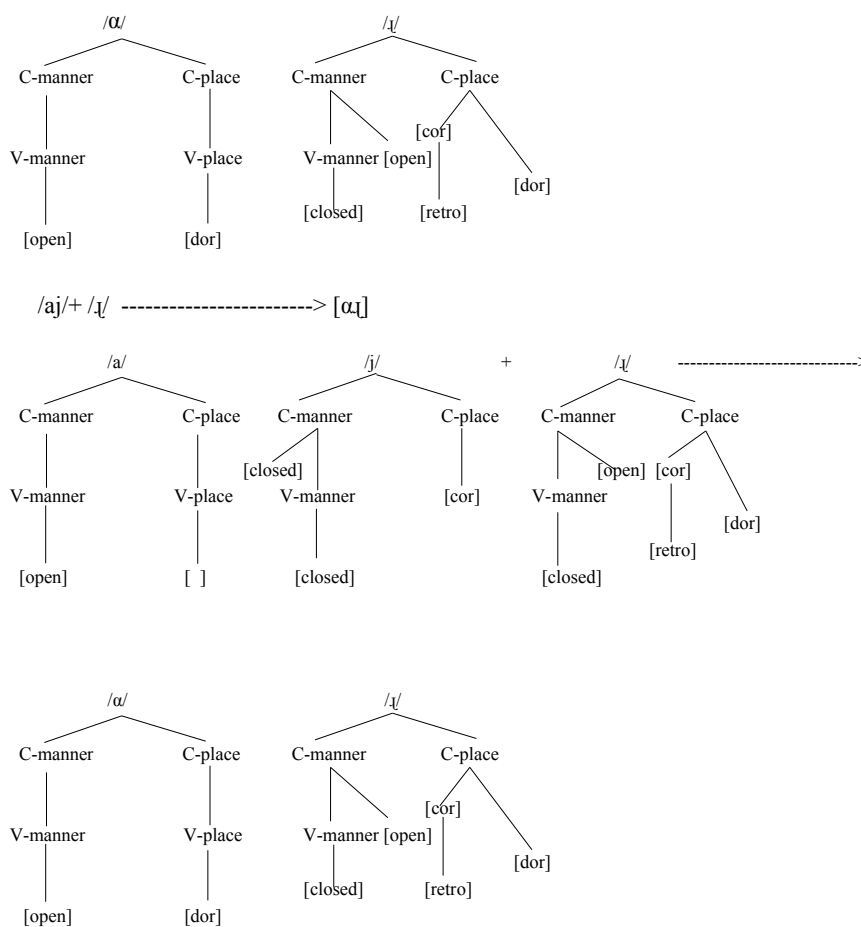

Given the structures above, the retroflex suffix assimilates the dorsal feature in place. The assimilation makes the low front vowel retract to be the back vowel. As to the mid vowels, the allophone [ɛ] of [ə] has the assimilation of dorsal feature and add another [cor] feature to become a retroflex vowel. The allophone [o] which has a dorsal feature remains the same. Due to the consonantal cluster, all the finals are deleted after the retroflex consonant is attached to.

In the third group,

- kəŋ + ɿ -----> kãɿ
- təŋ + ɿ -----> tãɿ
- ljəŋ + ɿ -----> ljãɿ
- uəŋ + ɿ -----> uãɿ
- k<sup>h</sup>wəŋ + ɿ -----> k<sup>h</sup>wãɿ
- k<sup>h</sup>uŋ + ɿ -----> k<sup>h</sup>ũɿ
- ɛiuŋ + ɿ -----> ɛiũɿ

Then we can summarize it,

- /aŋ/ + /ɿ/ -----> [ãɿ]
- /əŋ/ + /ɿ/ -----> [ẽɿ]
- /uŋ/ + /ɿ/ -----> [ũɿ]

From the data, we can see that the velar nasal in the coda position first nasalized the nuclear vowel and then get deleted. I will apply the PSM feature geometry as well to analyze the phenomenon.

/aŋ/ + /ɹ/ -----> [ãɹ]

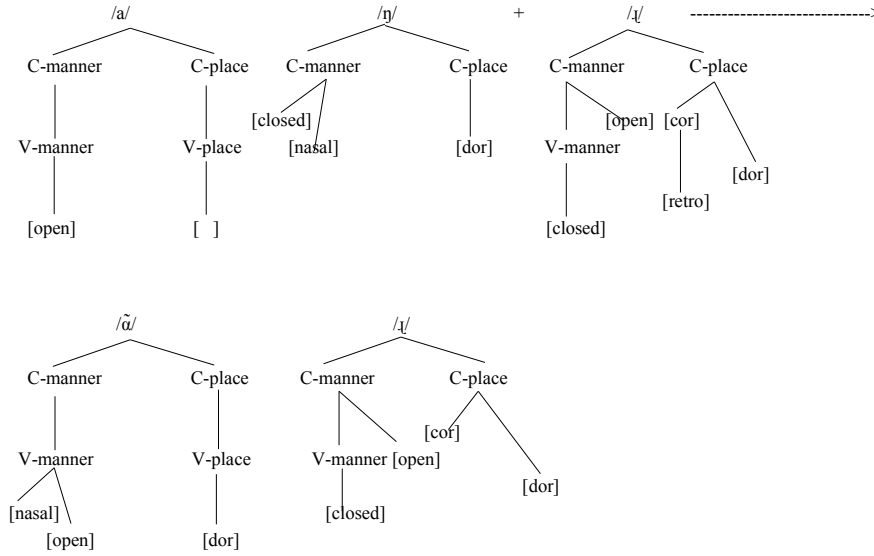

/əŋ/ + /ɹ/ -----> [ẽɹ]

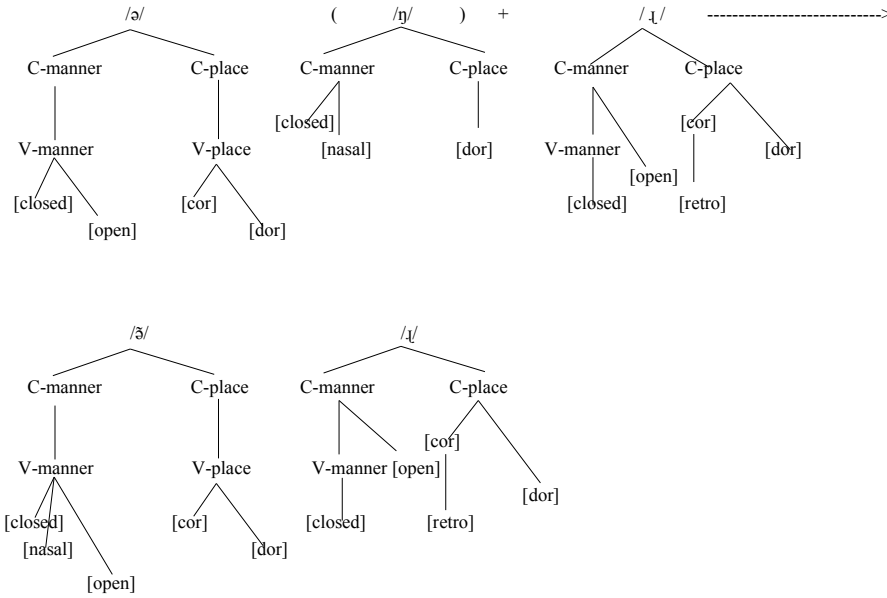

/uŋ/ + /ɹ/ -----> [ũɹ]

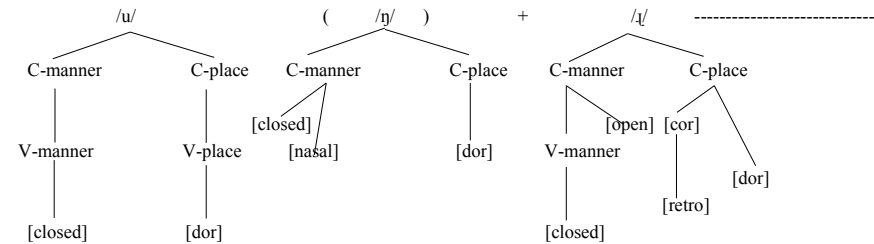

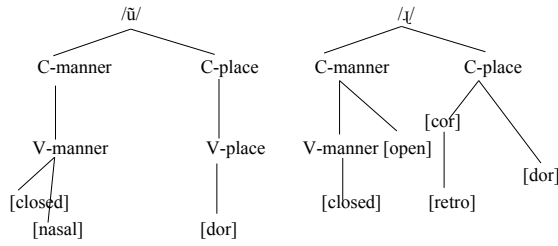

With an assimilation of the dorsal feature in place from the retroflex consonant, the low vowel retracted to be a back vowel and all other vowels which have the dorsal feature are not being affected. Then before the velar nasal gets deletion itself, it assimilates the vowel as well in nasalization. Therefore, the nuclear vowel gets assimilation and have the [nasal] feature in V-manner. And the retroflex feature [retro] is still in the retroflex consonant.

In the fourth group,

- S + ɿ ----->Səɿ
- tʂ + ɿ ----->tʂəɿ
- y + ɿ ----->yəɿ
- te<sup>h</sup>yn+ɿ -----> te<sup>h</sup>yəɿ
- tɛi+ɿ -----> tɛjəɿ
- tɛin+ɿ -----> tɛjəɿ
- iŋ+ɿ -----> jɛɿ

We can sum it up as below,

- /ø/+ /ɿ/ -----> [əɿ]
- /y/ + /ɿ/ -----> [ʏəɿ]
- /yn/+ /ɿ/ -----> [ʏəɿ]
- /i/ + /ɿ/ -----> [jəɿ]
- /in/ + /ɿ/ -----> [jəɿ]
- /iŋ/ + /ɿ/ -----> [jɛɿ]

In the first glance, we choose to neglect the final nasal deletion and final nasalization of the nuclear vowels. There is an insertion of the retroflex vowel /ə/ between the retroflex consonant and apical vowels and the apical vowels become pre-nuclear glides. The procedure is much more complicate than the first three groups. Hence, we first apply the PSM feature geometry.

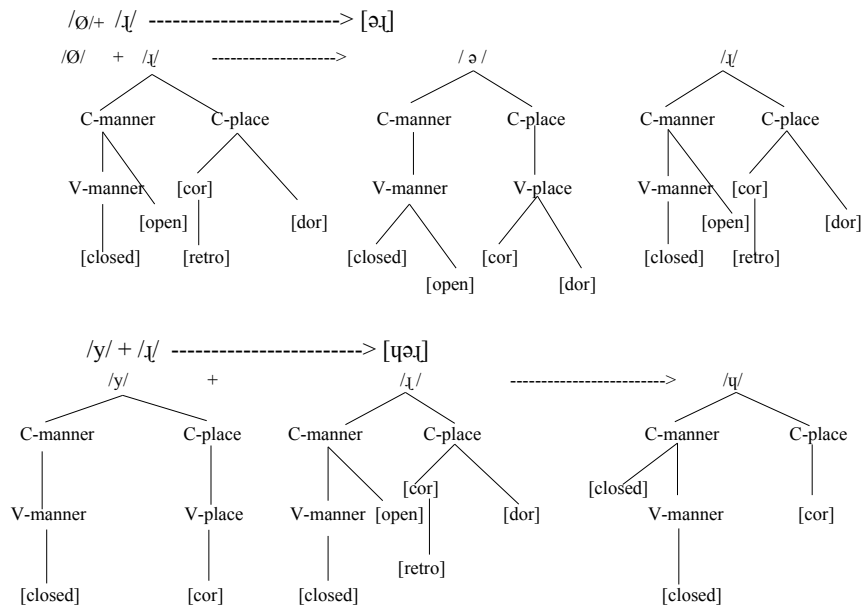

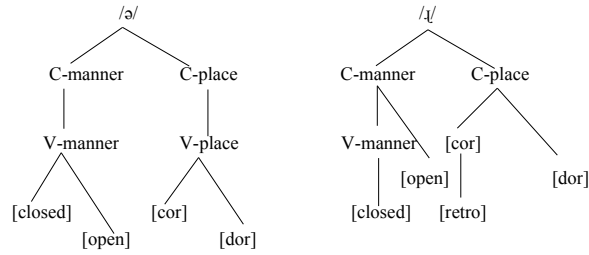

/yn/ + /ɪ/ -----> [ɥəɪ]

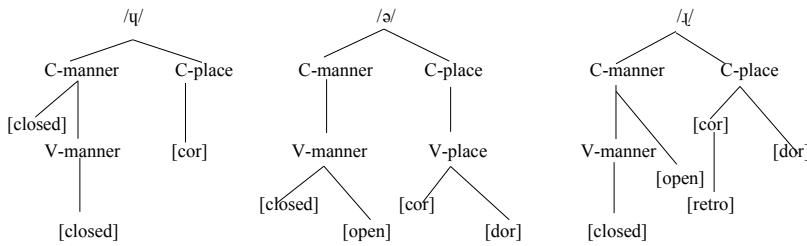
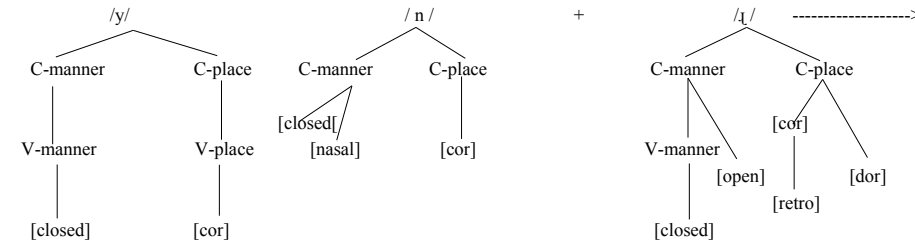

/i/ + /ɪ/ -----> [jəɪ]

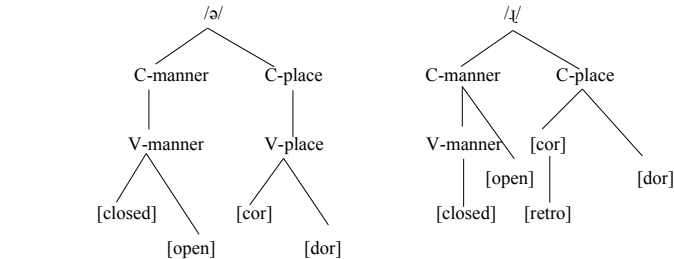
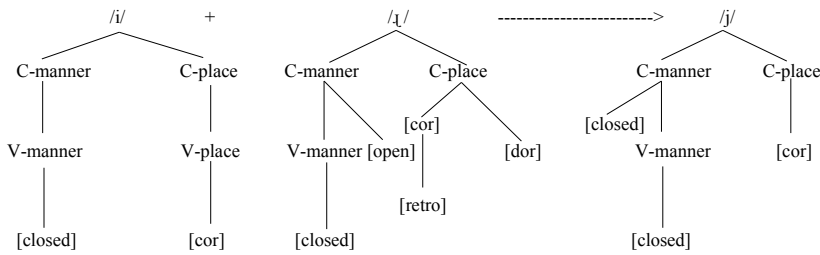

/in/ + /ɪ/ -----> [jəɪ]

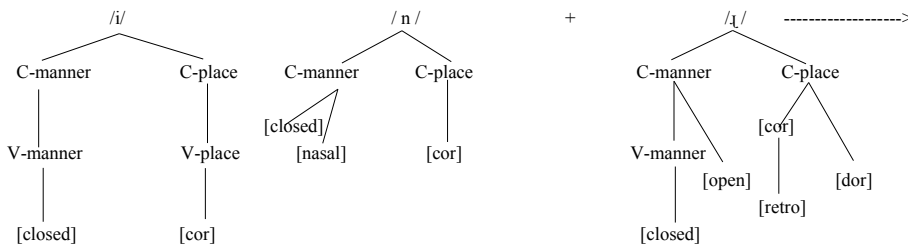

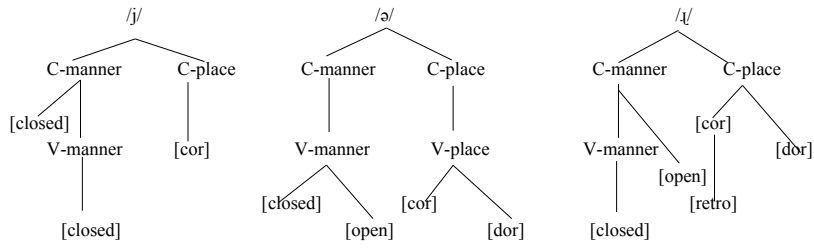

/iŋ/ + /ɹ/ -----> [j̥ɹ̥]

I)

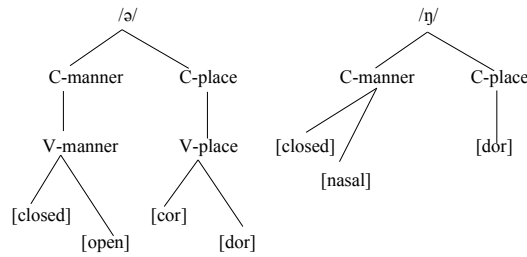
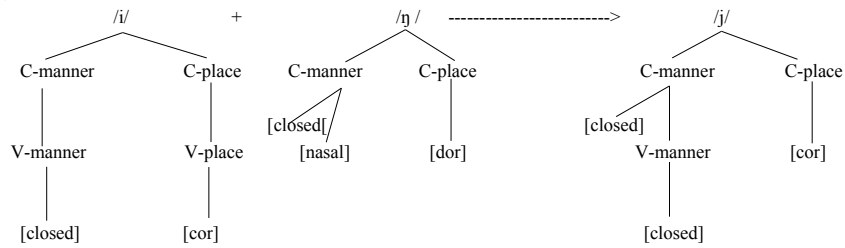

II)

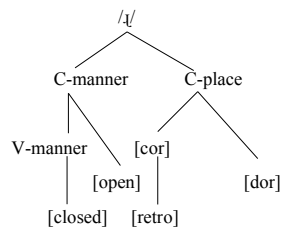
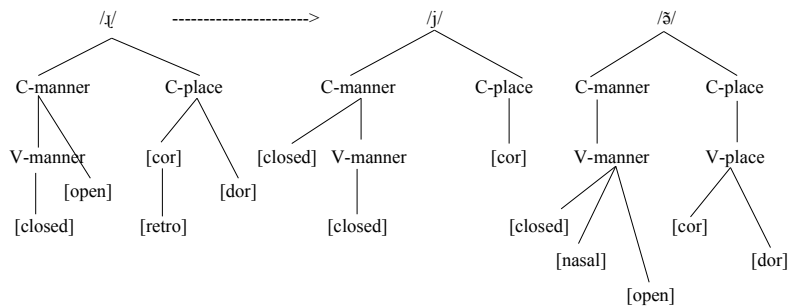
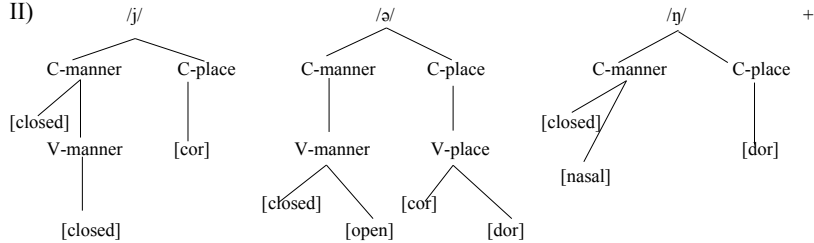



The indigestible part of the retroflex suffixation is about spreading the dorsal feature to the high front vowel /i/, /y/. The high front vowels are not compatible to be retroflexed, so the high front vowel becomes a pre-nuclear glide to maintain its feature. Thus, in order to suffice the normal CVC structure in words, there comes a retroflex vowel, which owns both the [cor] and [dor] features. When the word has a velar nasal ending, before the deletion of the velar nasal ending, the vowel receives a nasal feature from the velar nasal. In the first example, there is a vacancy in the vowel position, thus, the retroflex vowel fills in to complete the retroflex suffixation. And from the second to the fifth example, neglecting the deletion of the alveolar nasal in coda, the high vowels /i/ and /y/ both turn to be the pre-nuclear glides and retroflex vowel /ə/ inserts in between. In the sixth example, I propose that there are two procedures. In the first skeleton, there is an insertion of the retroflex vowel. This proposal is also adopted by Wang (1963:22), who indicated that the [iŋ] is actually pronounced as [iəŋ]. Then after the insertion, the second skeleton is about the nasalization of the retroflex vowel. From the data and the analysis above, I propose that the dorsal feature of the retroflex consonant is the key for retracting all the vowels in the nuclear position to the back. From the data, we can see that without a consonant ending in the syllable, the vowels such as [u], [ə] which have the dorsal feature remain steady and unchangeable and the retroflex suffix is directly attached to the stem, while the vowel such as /a/ which doesn't have the dorsal feature will accept the dorsal feature of the retroflex consonant and retract to the back to become an allophone of the phoneme. As to the high front vowels, they maintain their features but turn to a pre-nuclear glide. The retroflex vowel comes in between to finish the CVC structure. The syllable which has a alveolar nasal ending will eliminate the alveolar nasal ending in the first place, and then the procedure of adding retroflex suffix is as the same as adding retroflex suffix to the syllable without consonant endings. The syllable with a velar nasal ending will first nasalize the nuclear vowel and then delete itself, when the retroflex suffixation is attaching to the rime. As to the examples /iŋ/ + /ɿ/ -----> [jɿ̃ɿ], there are several arguments about the underlying forms of the [iŋ] and also about whether the nasalization of the nuclear vowels is before the retroflex suffix is attached to or after. Despite of all the conflict talk, in this paper, I apply the Parallel Structure of Feature Geometry (Morén, 2003) to analyze the phenomenon of the retroflex suffixation. Compared with other feature geometry, the Parallel structure of Feature Geometry covers a concise way of how to combine the features, since Feature Geometry (Clement, 1991) involves too many features for describing vowels and consonants. The PSM is a simple and precise innovation on phonological feature specifications.

And when it is referring to the feature of nasal, the Feature Geometry (Clement, 1991) doesn't make a clear statement in the nasals, since it is a contradict issue by assuming it as a stop or continuant sonorant. In this paper, I will adopt the nasals in the coda position as stops and the feature of the nasal will be in the Manner of the structure, equal to the [closed] and [open] features. Then we discover that the consonant assimilates the nuclear vowel by nasalization and the retroflex consonant tries to assimilate the final vowel in dorsal features as well. It proves that in Mandarin words, the nuclear vowel has a related co-articulation with the preceding retroflex consonant and the consonants in the final endings.

With a deep insight of how the retroflex suffix fuses into the main syllable on feature specifications, we may have the wonder that how the universal constraints select the candidates and make the harmony of the vowels with the retroflex suffix. Therefore, we will make an account of OT for the phenomenon of the retroflex suffixation in the following paragraphs.

## 2.4. The Optimality Theory Account

The classic OT (Prince and Smolensky, 1993; McCarthy and Prince, 1993a) is aroused by a series of internal interaction between conflicting constraints in the surface forms of the language. The goal of OT is to account for the phonological phenomena through a selection of a hierarchy ranking to select the best candidate. The former rule-based approaches (Kenstowicz and Kisseberth, 1977; Goldsmith, 1976) will load the burden to the constraints in OT (Patrick A. Bye, 2002). The basic components of OT are GEN, which generates possible competitors of the outputs and also includes the outputs themselves, EVAL which selects the optimal candidate through a language-specific constraint hierarchy, and Input&Output. The schema can be as such,



The infinitive candidates as Inputs come to GEN to select possible candidates and then through a specific constraint hierarchy EVAL, finally cut down to the optimal one. As to the constraints, there are two types of constraints: Faithfulness constraints—to maintain the same features from the input to the output, and the Markedness constraints—to perform the actor of well-formedness in outputs. The markedness constraints provoke the alter in the phonological structures, whereas the faithfulness constraints maintain the phonological structures to be consistent. The interaction between the Faithfulness and Markedness constraints constitutes the whole selection and help to choose the best candidate.

Here in order to get a better answer of how the retroflex suffixation affects the stem with a phonological account, I will apply classic OT to this phenomenon of suffix-triggered stem alternation. First of all, the constraints which are concerned are advanced in hand to constitute the hierarchy. In this section, the systematic account will be given under the theory of classic OT.

In the beginning, we have to turn to our examples that are in groups,

/ə/ + /ɪ/ -----> [əɪ]  
 /a/ + /ɪ/ -----> [aɪ]  
 /u/ + /ɪ/ -----> [uɪ]  
 /əj/ + /ɪ/ -----> [əɪ]  
 /ən/ + /ɪ/ -----> [əɪ]  
 /əw/ + /ɪ/ -----> [əɪ]  
 /an/ + /ɪ/ -----> [aɪ]  
 /aj/ + /ɪ/ -----> [aɪ]  
 /aŋ/ + /ɪ/ -----> [ãɪ]  
 /əŋ/ + /ɪ/ -----> [ẽɪ]  
 /uŋ/ + /ɪ/ -----> [ũɪ]  
 /ø/ + /ɪ/ -----> [øɪ]  
 /y/ + /ɪ/ -----> [yøɪ]  
 /yn/ + /ɪ/ -----> [yøɪ]  
 /i/ + /ɪ/ -----> [jəɪ]  
 /in/ + /ɪ/ -----> [jəɪ]  
 /iŋ/ + /ɪ/ -----> [jẽɪ]

We can see the final approximants /j/ and /w/ are deleted because there is a consonant cluster in the coda, since Mandarin syllables don't allow consonant clusters in the coda position. Therefore, I propose one markedness constraint---No complex coda  $*CC]_{\sigma}$  to rule out the final clusters,

$*CC]_{\sigma}$

No complex coda is allowed in a syllable.

The constraint of avoiding coda complexity (Blevins, 1995) is based on the languages which has closed syllables and prevent from complex finals. It functions as provoking the stem alternation and grounded as a certain type that some syllables are over chosen others. In Mandarin, it is allowed to have complex onsets but disallowed complex coda. Henceforth, this constraint is forged into a dominate position in Mandarin. And since the markedness constraint is lift up, the relative faithfulness constraint I propose that is No Deletion—MAX-IO, which is the contradict one against the final coda deletion.

MAX-IO

The segment in the input has a correspondence in the output.

It is, or rather, a prevention from deletion. In Mandarin, the constraint--- $*CC]_{\sigma}$  should dominate the faithfulness constraint MAX-IO. Otherwise, many forbidden forms such as  $*/kaj_{\downarrow}/, */kaw_{\downarrow}/$  will be valid. The hierarchy will be  $*CC]_{\sigma} \gg \text{MAX-IO}$ . In the following tableaux, the optimal candidate will be marked with a special “→” and the violation of the candidate will be marked with an asterisk “\*”. If the violation is fatal, it will be marked with an exclamation mark “!”.

		$*CC]_{\sigma}$	MAX-IO
/əj/+ /ɿ/	→ [əɿ]		*
	[əjɿ]	*!	
/əw/+ /ɿ/	→ [əɿ]		*
	[əwɿ]	*!	

The first violation in the ranking will be fatal. Due to that the markedness constraint is over ranked than the faithfulness constraint, the optimal candidate is favored with a single coda. Then Although the first candidates of each group have a violation of no deletion, they are still optimal.

Given the data,

/a/+ /ɿ/ ----->[aɿ]  
 /an/+ /ɿ/ ----->[aɿ]  
 /aj/+ /ɿ/ ----->[aɿ]

we will see that the low vowel retracts to the back position and the retroflex suffix spreads its dorsal feature to the preceding vowel. Then the next constraint I propose is  $V_{[dor]_{\downarrow}}$  constraint.

$V_{[dor]_{\downarrow}}$

The vowels must have a [dorsal] feature in front of a retroflex consonant.

It is a markedness constraint that narrows vowels down and require the vowels to have a dorsal feature. The vowels such as high front vowels or mid front vowels will be ruled out. To be in contrast, there will be a faithfulness constraint, which will help to keep the consistent of the input and the output. Hence, I propose IDENT-IO(F) (Kager, 1999:250) to avoid changes.

IDENT-IO[F]

Correspondent segments have the identical feature in the input and the output.

This constraint demands the identification of the feature in the input and the output. Thus, it prevents the vowels to have a change of the feature. This constraint should be low-ranked because the low vowel [a] retracts itself to the back and become a [ɑ], which has a dorsal feature to fit in the assimilation with the retroflex consonant. Therefore, the hierarchy is  $V_{[dor]L} \gg IDENT-IO[F]$ .

so the tableau is as below,

		*CC] <sub>σ</sub>	MAX-IO	V <sub>[dor]L</sub>	IDENT-IO[F]
/aj/+/ɹ/	[aɹ]		*	*!	
	[ajɹ]	*!			
	→[ɑj]		*		*
	[ɑjɹ]	*!			

		*CC] <sub>σ</sub>	MAX-IO	V <sub>[dor]L</sub>	IDENT-IO[F]
/an/+/ɹ/	[aɹ]		*	*!	
	[anɹ]	*!			
	→[ɑɹ]		*		*
	[ɑnɹ]	*!			

The tableau indicates that the underlying phoneme surfaces as a back low vowel. With a fatal complex coda violation, the second and the fourth candidates are ruled out. Then although the first and the third candidates violates the faithfulness constraint--no deletion, they are still optimal, due to the hierarchy  $*CC]_{\sigma} \gg MAX-IO$ . After that, The comparative candidates have to have a competition to select one best candidate. The dorsal feature is more essential in participating in the competition, therefore, the third candidate which has a dorsal feature will be chosen to be the best one over the first candidate. Therefore, the first candidate is out although it doesn't change its feature.

Then we turn to the data of the third group,

- /ø/ + /ɹ/ -----> [əɹ]
- /y/ + /ɹ/ -----> [ʏəɹ]
- /yn/ + /ɹ/ -----> [ʏəɹ]
- /i/ + /ɹ/ -----> [jəɹ]
- /in/ + /ɹ/ -----> [jəɹ]
- /iŋ/ + /ɹ/ -----> [jəɹ]

We can see that there comes a pre-nuclear glide in the onset part, which originates from a high front vowel and also an insertion of the retroflex vowel in between. The insertion of the vowel is a retroflex vowel, but why the vowel can't be a back vowel of [ɑ], [u], since they all have the dorsal feature. Therefore, the epenthetic segment has to be chosen by special constraints. Kager (1999:124) has cited that epenthetic segments tend to be “minimally marked”. The feature selection of the epenthetic segment is dependent on the markedness constraints. With a consideration of the unmarked vowels in Mandarin sound inventory, [i], [ə] are cross-linguistically less unmarked. And [i] doesn't have a dorsal feature, so it is only [ə] compatible for being a epenthetic vowel. Hence, I propose some markedness constraints.

\*[+round]----the epenthetic vowel can't be a round vowel.

\*[+low]----- the epenthetic vowel can't be a low vowel.

After that, the faithfulness constraint is brought forward to prevent from an insertion.

DEP-IO

The segment in the output has a correspondence in the input.

The constraint DEP-IO is higher ranked, because from the data, we can see that the vowels should be faithful to their input and not be affected by context-free markedness constraint. The two constraints have their function only after they have been valued through DEP-IO. Hence, I propose the following tableau with a hierarchy that the context-free markedness constraint is lower ranked faithfulness constraint,

		*CC] <sub>σ</sub>	MAX-IO	V <sub>[dor]L</sub>	DEP-IO	*[+low]	*[+round]	IDENT-IO[F]
/i/+/ɿ/	[iɿ]			*!				
	→[jəɿ]				*			*
	[jɑɿ]				*	*!		*
	[juɿ]				*		*!	*
	[əɿ]		*!		*			*
	[jɿ]	*!						

First of all, the sixth candidate violates the fatal constraint---no complex coda and is kicked out. Then the fifth candidate which deletes the high front vowel fails to satisfy the MAX-IO. After that, the demand for a dorsal feature of a vowel rules out the first candidate. Here, I propose that the place of constraints \*[+round] and \*[+low] can be interchangeable. The two constraints select the inserted vowel to be less marked. So the vowels [ɑ] and [u] are not suitable about being the inserted vowel and being out. Thus, although the second candidate violates DEP-IO and INDENT-IO[F], it is the optimal one.

Then there rises another problem that is why the inserted vowel can't be [ɤ], the allophone of the retroflex vowel. The [ɤ] has a dorsal feature and it is neither round or low. Hence, another constraint is necessary to be brought forward. As we can see, the epenthetic vowel tends to be less marked. The only reason to rule out the vowel [ɤ] is that [ɤ] is unround back vowel, which is more marked than [ə]. The back vowels have the attempt to be round, while the front vowel have the opposite attempt in Mandarin. Hence, we can rule out the vowel [ɤ] by this constraint,

\* Back-unround  
 Back vowels have to be round.

		*CC] <sub>σ</sub>	MAX-IO	V <sub>[dor]</sub> ]	DEP-IO	*[+low]	*[+round]	*Back-unround	IDENT-IO[F]
/i/+/ɹ/	[iɹ]			*!					
	→[jəɹ]				*				*
	[jɑɹ]				*	*!			*
	[juɹ]				*		*!		*
	[əɹ]		*!		*				*
	[jɹ]	*!							
	[jɹ̃]				*			*!	

Then we turn to the hot issue about the nasalization of the nuclear vowel by the velar nasal. This issue has been discussed for a long time. However, the variable proposals never reached to an agreement. The syllable is always considered as CVn when there is a alveolar nasal in the coda position and is considered as C $\tilde{V}$ ŋ when there is a velar nasal in the coda position. Recall what we have talked about the feature spreading, the velar nasal has a dorsal feature and also a nasal feature, whereas the alveolar nasal has a coronal feature and a nasal feature.

- /əŋ/ +/ɹ/ -----> [ə̃ɹ]
- /aŋ/ +/ɹ/ -----> [ãɹ]
- /uŋ/ +/ɹ/ -----> [ũɹ]
- /iŋ/ +/ɹ/ -----> [j̃ə̃ɹ]
- /aŋ/ +/ɹ/ -----> [ɑɹ]
- /əŋ/ +/ɹ/ -----> [əɹ]
- /iŋ/ +/ɹ/ -----> [jə̃ɹ]

The behaviors of the two nasals are different. Before the deletion of the final nasals, the velar nasal assimilates the vowel and makes the vowel nasalized. As to the alveolar nasal, it is deleted at once without nasalizing the nuclear vowel. The question is why the velar nasal passes its feature to the nuclear vowel, while the alveolar nasal doesn't. It seems that the dorsal feature will be more preserved than the coronal feature. Hence, here I apply to the constraint as below,

Correspondence (McCarthy and Prince, 1995)

Given two strings S<sub>1</sub> and S<sub>2</sub>, *Correspondence* is a relation *R* from the element of S<sub>1</sub> to those of S<sub>2</sub>. Segments  $\hat{a} \in S_1$  and  $\hat{a} \in S_2$ , as referred to as correspondents of one another when  $\hat{a} R \hat{a}$ .

Here I adopt Lili Ma's (1997) proposal,

- CORR(string1, string2, X)
  - a. X is a constituent  $\in$  string1.
  - b. X is a set of feature specifications: X={F<sub>1</sub>,F<sub>2</sub>....F<sub>n</sub>}
- At least one node of every X in string<sub>1</sub> must be coindexed with a node of the same type in string<sub>2</sub>.

Then the constraint for preventing eliminating the nasal feature of the velar nasal is

CORR(I, O, [ŋ])

Features of [ŋ] in the output have a correspondence in the input.

This constraint is specific for reserving the feature of the velar nasal. And another constraint is also proposed as a markedness constraint.

\*V<sub>nasal</sub>

Vowels must not be nasal.

This constraint is to make sure that the vowels in front of the alveolar nasal are not nasalized. Hence the faithfulness constraint should be higher ranked than the markedness constraint.

And the nasalization will be solved in th tableau,

/iŋ/+/ɹ/		*CC] <sub>σ</sub>	MAX -IO	V <sub>[dɔr]ɹ</sub>	DEP -IO	*[+low]	*[+round]	*Back -unround	COR R(I,O ,[ŋ])	*V <sub>nasal</sub>	IDE NT- IO
	[iŋɹ]	*!									
→	[jɔ̃ɹ]				*					*	**
	[jɔ̃ɹ]				*	*!				*	**
	[jũɹ]				*		*!			*	**
	[ɔ̃ɹ]		*!		*					*	***
	[jɔɹ]				*				*!		**
	[jɹɹ]				*			*!	*		**

In the tableau, the first candidate is ruled out because of the fatal consonantal cluster. Then no deletion of the vowel has kicked out the fifth candidate. Then the markedness constraints \*[+low], \*[+round], \*Back-unround rule out the candidates which have other inserted vowels instead of the retroflex vowel. Next, the faithfulness constraint which prevents the deletion of feature of the [ŋ] kicks the sixth candidate out. Then although the second candidate violates the constraint which prevents vowels to be nasalized, it is the optimal one. Then we apply the same hierarchy of constraints to the retroflex suffixation of the alveolar nasal. The tableau is as followed,

/iŋ/+/ɹ/		*CC] <sub>σ</sub>	MAX -IO	V <sub>[dɔr]ɹ</sub>	DEP -IO	*[+low]	*[+round]	*Back -unround	CORR (I,O,[ŋ])	*V <sub>nasal</sub>	IDE NT- IO
	[iŋɹ]	*!									
	[jɔ̃ɹ]				*					*!	**
	[jɔ̃ɹ]				*	*!				*	**
	[jũɹ]				*		*!			*	**
	[ɔ̃ɹ]		*!		*					*	***
→	[jɔɹ]				*						**
	[jɹɹ]				*			*!			**

The only difference from the tableau of the retroflex suffixation is that the faithfulness constraint CORR(I,O,[ŋ]) doesn't have a function in this tableau. Thus, the markedness constraint \*V<sub>nasal</sub> takes the responsibility to rule out the nasalized vowel. Therefore, the process of the retroflex suffixation will be analyzed as below. However, with another proposal, the Parallel Structure of Feature Geometry is a simple way to account for the phonological process in retroflex suffixation. Hence, in another way, I apply to the Parallel Structure of Feature Geometry and Correspondence Theory (McCarthy and Prince, 1995). And the constraints which are proposed by (Morén, 2007) will be adopted here. The feature markedness and faithfulness constraints I cite from Morén (2007) will be as below,

\*C-manner[closed]  
 assign a violation mark for every C-manner[closed].  
 \*V-manner[closed]  
 assign a violation mark for every V-manner[closed]  
 MAXC-manner[closed]  
 assign a violation mark for every C-manner[closed] in the input that does not have a correspondence in the output(no deletion).  
 MAXV-manner[closed]  
 assign a violation mark for every V-manner[closed] in the input that does not have a correspondence in the output(no deletion).  
 DEPC-manner[closed]  
 assign a violation mark for every C-manner[closed] in the output that does not have a correspondence in the input(no insertion).  
 DEPV-manner[closed]  
 assign a violation mark for every V-manner[closed] in the output that does not have a correspondence in the input(no insertion).

And Morén (2007) also proposes that the phonological grammar is economical and uses a combination of primitive constraints to form more complex constraints.

Then the local conjunction (Smolensky,1997) is adopted.

Local Conjunction (Smolensky,1997)-The local conjunction of C<sub>1</sub> and C<sub>2</sub> in domain D, C<sub>1</sub>&C<sub>2</sub>, is violated when there is some domain of type D in which both C<sub>1</sub> and C<sub>2</sub> are violated.

\*C-manner[closed] & \*V-manner[closed]-the local conjunction of \*C-manner[closed] and \*V-manner[closed] is violated when both \*C-manner[closed] and \*V-manner[closed] are violated by the same segment.

Recall the data of our first group which doesn't have a final ending in the syllable as below,

/ə/ +/ɣ/----->[əɣ]  
 /a/ +/ɣ/ ----->[aɣ]  
 /u/ +/ɣ/ ----->[uɣ]

Then here I apply one markedness constraint to demand the dorsal feature in vowels and also one faithfulness constraint to avoid the alternation,

V-place[dorsal]<sub>t</sub>

Vowels must have a dorsal feature in V-place in front of a retroflex consonant.



## MAXV-manner[closed]

assign a violation mark for every V-manner[closed] in the input that does not have a correspondence in the output(no deletion).

## MAXV-manner[open]

assign a violation mark for every V-manner[open] in the input that does not have a correspondence in the output(no deletion).

## DEPV-manner[closed]

assign a violation mark for every V-manner[closed] in the output that does not have a correspondence in the input(no insertion).

## DEPV-manner[open]

assign a violation mark for every V-manner[open] in the output that does not have a correspondence in the input(no insertion).

		V-place[dorsal] <sub>I</sub>	MAXV-manner[closed]	MAXV-manner[open]
/ə/+ /ɪ/	→ [əɪ]			
	[ɑɪ]		*!	
	[uɪ]			*!
	[iɪ]	*!		*
	[yɪ]	*!		*

		V-place[dorsal] <sub>I</sub>	DEPV-manner[closed]	MAXV-manner[open]
/a/+ /ɪ/	[əɪ]		*!	
	→ [ɑɪ]			
	[uɪ]		*!	*
	[iɪ]	*!	*	*
	[yɪ]	*!	*	*

		V-place[dorsal] <sub>I</sub>	MAXV-manner[closed]	DEPV-manner[open]
/u/+ /ɪ/	[əɪ]			*!
	[ɑɪ]		*!	*
	→ [uɪ]			
	[iɪ]	*!		
	[yɪ]	*!		

Hence, as we can see, the MAX and DEP can be merged into one constraint IDENT. Then I propose the IDENT constraints in the retroflex suffixation,

## IDENTV-manner[closed]

The V-manner[closed] has a correspondence in the input and the output(no deletion and no insertion).

IDENTV-manner[open]

The V-manner[open] has a correspondence in the input and the output (no deletion and no insertion).

Since keeping the nuclear vowel faithful is less priority than the markedness constraint V-place[dorsal]<sub>L</sub>, the hierarchy should be V-place[dorsal]<sub>L</sub> >> IDENTV-manner[closed], IDENTV-manner[open].

Then when we refer to the data from the second group, we can see that

/əj/+ /ɹ/ -----> [əɹ]  
 /ən/+ /ɹ/ -----> [əɹ]  
 /əw/+ /ɹ/ -----> [əɹ]  
 /an/+ /ɹ/ -----> [ɑɹ]  
 /aj/+ /ɹ/ -----> [ɑɹ]

The deletion which is caused by the forbidden of the consonantal cluster should be due to a markedness constraint. As we can see from the tableau before, The final consonants all have a C-manner [closed]. Hence, I propose the markedness constraint,

\*C-manner[closed]

assign a violation mark where there is a C-manner[closed].

		*C-manner[closed]	V-place[dorsal] <sub>L</sub>	IDENTV-manner[closed]	IDENTV-manner[open]
/əj/+ /ɹ/	→ [əɹ]				
	[əjɹ]	*!			
	[uɹ]				*!
	[iɹ]		*!		*
	[yɹ]		*!		*
	[ɑɹ]			*!	

As in the first proposal, the markedness constraint is higher ranked to rule out the consonantal cluster in the coda position. Then the dorsal feature in V-place kicks out the front vowel such as [i] and [y]. After that, the faithfulness constraints which require no feature insertion and no feature deletion in V-manner. Hence the nuclear vowel maintains itself instead of having an alternation of other vowels. Our optimal candidate will be the first one, with a deletion of the final consonant and have a retroflex approximant affiliation.

Then we turn to the groups that the velar nasals have the nasalization of the nuclear vowels, while the alveolar nasals don't.

/əŋ/+ /ɹ/ -----> [ɛ̃ɹ]  
 /aŋ/+ /ɹ/ -----> [ɑ̃ɹ]  
 /uŋ/+ /ɹ/ -----> [ũɹ]  
 /iŋ/+ /ɹ/ -----> [jɛ̃ɹ]  
 /an/+ /ɹ/ -----> [ɑɹ]  
 /ən/+ /ɹ/ -----> [əɹ]  
 /in/+ /ɹ/ -----> [jəɹ]

The different behaviors of the nasal consonants will be proposed as an effect of the local conjunction (Smolensky, 1997).

The PSM structure of  
/ŋ/ & /n/

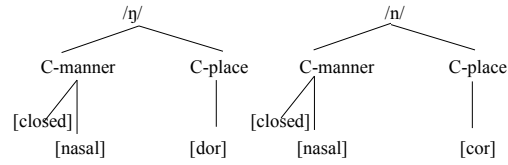

Local Conjunction (Smolensky, 1997)-The local conjunction of  $C_1$  and  $C_2$  in domain  $D$ ,  $C_1 \& C_2$ , is violated when there is some domain of type  $D$  in which both  $C_1$  and  $C_2$  are violated. Then I propose that,

MAX[nasal]&MAX[dorsal]-the local conjunction of feature[nasal] and feature[dorsal] is violated when both feature [nasal] and feature [dorsal] are deleted.

MAX[nasal]&MAX[coronal]-the local conjunction of feature[nasal] and feature[coronal] is violated when both feature [nasal] and feature [coronal] are deleted.

The two components as a combination into one constraint only function when both are violated. If one of them are violated, the whole constraint will not be violated. The idea is raised from the appearance of the opacity.

A-B and B-C, but not \*A-C

The retroflex suffixation is always considered as a procedure of the opacity. The procedure of opacity can be taken as

CVŋ+ɫ	----->	C $\tilde{V}$ ŋɫ	A-B
	nasalization		
C $\tilde{V}$ ŋɫ	----->	C $\tilde{V}$ ɫ	B-C
	deletion		
CVŋ+ɫ	----->	C $\tilde{V}$ ɫ	*A-C
	nasalization & deletion		

The whole procedure includes a nasalization of the nuclear vowel in the middle by the final velar nasal and a deletion of the final velar nasal. Thus, there are three rules in the process of the retroflex suffixation.

- a) /n/ deletion:            /n/ --> Ø /V\_ +/ɫ/
- b) /ŋ/ deletion:         /ŋ/ --> Ø /V\_ +/ɫ/
- c) Nasalization:         V -->  $\tilde{V}$  / \_N +/ɫ/

The first and second rules are indicating that the nasal finals are deleted when the retroflex suffix is attaching to the stem. The third rule explains that the nuclear vowel gets nasalization in front of a tautosyllabic nasal. It is noticing that the alveolar nasal is deleted before the nasalization of the nuclear vowel happens. However, the velar nasal first nasalizes the nuclear vowel and then gets deletion. The different priority varies the result. The derivations of the retroflex suffixation are given as below,

Input	/an/+/ɹ/	/aŋ/+ /ɹ/
/n/ deletion	αɹ	n/a
Nasalization	n/a	ãŋɹ
/ŋ/ deletion	n/a	ãɹ
Output	[αɹ]	[ãɹ]

Through the tableau, we can see that the procedure of the retroflex suffixation with an alveolar nasal ending is transparent, whereas with a velar nasal is opaque. If there is a rule P which destroys an environment for rule Q to apply, P>Q, it is a bleeding order. And if Q>P, both rules are applied, it is a counterbleeding order (Patrik Bye, 2002).

As we can see from the example of retroflex suffixation with an alveolar nasal, the “/n/ deletion” applies first so that the “nasalization” rule can't apply. Cited by Kiparsky (1982), If two phonological rules are said to be in bleeding order, the application of the first rule creates a context in which the second rule can no longer apply. Hence, the rule “/n/ deletion” to “nasalization” is a bleeding order. And the procedure of the retroflex suffixation with a velar nasal is that the “nasalization” fails to bleed the “/ŋ/ deletion”. It is a counterbleeding order. The counterbleeding arises when a rule's structural context is potentially removed by the application of a prior rule, but the ordering is such that both rules apply (Kager, 1999:375). The first rule “nasalization” and the second rule “/ŋ/ deletion” both apply and the whole creates a counterbleeding order.

The Classic OT is a selectional system to choose the optimal candidate through a hierarchy. The hierarchy is via the internal reciprocity of the faithfulness constraints and markedness constraints. The whole procedure only involves the mapping from the input to the output. However, it doesn't involve the intermediate step and the whole procedure neglects the derivation. Hence, if we apply a classic OT, the outcome of the output will be false. Take a tableau for example,

I propose a markedness constraint and a faithfulness constraint to identify how the opacity affected the optimal candidate.

\*V-manner[nasal]

assign a violation mark where there is a nasal feature in V-manner.

MAX[nasal]

the nasal feature has a correspondence from the input to the output (no deletion of the nasal feature).

/an/+ /ɹ/ -----> [αɹ]							
		*C-manner [closed]	V-place [dorsal]ɹ	IDENTV-manner [open]	IDENTV-manner [closed]	*V-manner [nasal]	MAX[nasal]
/an/+ /ɹ/	[ãɹ]					*!	
	→[αɹ]						*
	[uɹ]			*!	*		*
	[əŋɹ]	*!					
	[iɹ]		*!	*	*		*
	[yɹ]		*!	*	*		*
	[əɹ]				*!		*

/an/ + /ɹ/ -----&gt; [ãɹ]

		*C-manner [closed]	V-place [dorsal]ɹ	IDENTV-manner [open]	IDENTV-manner [closed]	*V-manner [nasal]	MAX[nasal]
/an/ + /ɹ/	[ãɹ]					*!	
	→*[aɹ]						*
	[uɹ]			*!	*		*
	[aŋɹ]	*!					
	[iɹ]		*!	*	*		*
	[yɹ]		*!	*	*		*
	[əɹ]				*!		*

As we can see from the two tables, the second one is pointing to the false candidate instead of the optimal one. Hence, as mentioned before, the local conjunction is appropriate to account for this effect. As to the ranking, since the preservation of the nasal feature which is carried by velar nasals is priority in the ranking, the MAX[nasal]&MAX[dorsal] will be higher ranked and the MAX[nasal] &MAX[coronal] will be lower ranked,

Hence, I propose that,

MAX[nasal]&MAX[dorsal]>>\*V-manner[nasal]>>MAX[nasal]&MAX[coronal]

/an/ + /ɹ/ -----&gt; [aɹ]

		*C-manner [closed]	V-place [dorsal]ɹ	IDENTV-manner [open]	IDENTV-manner [closed]	MAX[nasal]&MAX[dor]	*V-manner [nasal]	MAX[nasal]&MAX[cor]
/an/ + /ɹ/	[ãɹ]						*!	
	→[aɹ]							*
	[uɹ]			*!	*			*
	[əŋɹ]	*!						
	[iɹ]		*!	*	*			*
	[yɹ]		*!	*	*			*
	[əɹ]				*!			*

The first tableau is indicating about the retroflex suffixation with an alveolar nasal in coda position. Because every final consonant has a C-manner[closed], the constraint \*C-manner[closed] rules out the candidate in order to avoid consonantal cluster. Henceforth, the fourth candidate which has a fatal violation of the consonantal cluster is out. After that, the high front vowel will be kicked out due to the lack of the dorsal feature in V-place. With the faithfulness constraints IDENTV-manner[closed]&IDENTV-manner[open], the nuclear vowels which are not identical with original vowel are fatally out. Moreover, the first candidate violates the constraint that requires no nasal feature in V-manner and the optimal candidate is the second candidate, although it violates the local conjunction of MAX[nasal]&MAX[coronal].

/aŋ/ + /ɹ/ -----> [ãɹ]

		*C-manner [closed]	V-place [dorsal]ɹ	IDENTV-manner [open]	IDENTV-manner [closed]	MAX[nasal]& MAX[dor]	*V-manner [nasal]	MAX[nasal]& MAX[cor]
/aŋ/ + /ɹ/	→[ãɹ]						*	
	[aɹ]					*!		
	[uɹ]			*!	*	*		
	[aŋɹ]	*!						
	[iɹ]		*!	*	*	*		
	[yɹ]		*!	*	*	*		
	[əɹ]				*!	*		

In the second tableau, the former part is as the same as the first one. After ruling out all other unsuitable candidates, the local conjunction MAX[nasal]&MAX[dorsal] rules out the candidate which deletes the both features of the nasal and dorsal of the /ŋ/. Therefore, the best candidate is the one that is nasalized and with the deletion of the velar nasal. The opacity is solved by the local conjunction.

Then we turn to the group which has an insertion of the retroflex vowel and the high front vowel turning to a pre-nuclear glide,

/iŋ/ + /ɹ/ -----> [jãɹ]  
/in/ + /ɹ/ -----> [jəɹ]

In this group, we also pick up two contrast examples with an alveolar nasal and a velar nasal endings.

The proposal of the constraint \*C-manner[closed] is to rule out the consonantal cluster, because all the consonants in the coda position have the C-manner[closed]. However, this proposal also rules out the pre-nuclear glide. Thus, the modification is an essence in the first place. As we have mentioned the constraint \*CC]<sub>σ</sub> in the beginning, here with the similarity, I propose another constraint,

\*C-manner C-manner]<sub>σ</sub>

The appearance of two C-manners is forbidden in the coda position.

To make another modification, no deletion of the nuclear vowel is the priority among the faithfulness constraints. Hence, here the faithfulness constraints have to be divided into four constraints and the faithfulness constraints MAX will be in the higher ranking position because they prevent the deletion of the high front vowels. The tableau is given here,

/in/ + /ɹ/ -----&gt; [jəɪ]

		*C-manner C-manner] <sub>σ</sub>	V-place [dorsal] ɹ	MAXV-manner [open]	MAXV-manner [closed]	DEPV-manner [open]	DEPV-manner [closed]	MAX[nasal] &MAX[dor]	*V-manner [nasal]	MAX[na sal]&MA X[cor]
/in/ + /ɹ/	[jəɪ]					*	*		*!	
	→ [jəɪ]					*	*			*
	[uɪ]				*!		*			*
	[inɪ]	*!								
	[iɪ]		*!							*
	[yɪ]		*!		*		*			*
	[əɪ]				*!	*	*			*

In the first place, the \*C-manner C-manner]<sub>σ</sub> select the candidates with only one final consonant so that the fourth candidate is fatally out. Second, the dorsal feature is demanded in the structure, then the high front vowels which don't have will be kicked out. The MAXV-manner [closed]&MAXV-manner[open] require that there is no deletion of the high front vowels. Thus, the ones that eliminate the high front vowels will be not the optimal ones any more, such as [uɪ], [əɪ]. After that, we can see that only two candidates are left to the competition, the first one and the second one. Although, they both violate the faithfulness constraints DEP V-manner[closed]& DEP V-manner[open] which forbid the insertion of the vowels, they are now more optimal than other candidates. The constraint of the local conjunction MAX[nasal]&MAX[dor] is out of work in this tableau because the final consonant contains the features of nasal and coronal. Then the key constraint to rule out the candidate with a nasalization is \*V-manner[nasal]. It demands no nasal feature attaching to the V-manner. Therefore, the optimal candidate is the second one which only deletes the final nasal. And the retroflex suffixation of the velar nasal is as below,

/iŋ/ + /ɹ/ -----&gt; [jəɪ]

		*C-manner C-manner] <sub>σ</sub>	V-place [dorsal] ɹ	MAXV-manner [open]	MAXV-manner [closed]	DEPV-manner [open]	DEPV-manner [closed]	MAX[nasal] &MAX[dor]	*V-manner [nasal]	MAX[na sal]&MA X[cor]
/iŋ/ + /ɹ/	→ [jəɪ]					*	*		*	
	[jəɪ]					*	*	*!		
	[uɪ]				*!		*	*		
	[iŋɪ]	*!								
	[iɪ]		*!					*		
	[yɪ]		*!		*		*	*		
	[əɪ]				*!	*	*	*		

The procedure is similar to the last one before. The only differ is the final part about the opacity of the nasalization. The dorsal feature and nasal feature are not allowed to be omit, hence the second candidate is kicked out. Although the first candidate violates the \*V-manner[nasal], it

wins in the competition as an optimal one. To sum up, the ranking for the retroflex suffixation with an analysis of PSM features will be as followed,

\*C-mannerC-manner]σ>>V-place[dorsal]>>MAXV-manner [open], MAXV-manner[closed]>> DEPV-manner[open], DEPV-manner[closed]>>MAX[nasal]&MAX[dor]>>\*V-manner[nasal] >>MAX[nasal]&MAX[cor].



## Chapter 3

# Phonological Analysis

### ---The Analysis with The Underlying Form of the Retroflex Suffix As a floating feature

#### 3.1.The OT Account

It is commonly discussed that though times, the retroflex suffix has lost its own segment and becomes a floating feature. In the following paragraph, I will discuss about how the retroflex suffix as a floating feature is attached to the stem. In this part, I take the retroflex suffix as a [+r]. Since with a deletion of the final nasal, the nuclear vowel will become a long vowel, Hence, we can now turn to the data, then I summarize the procedure of the retroflex suffix as below, which occupies two moras. Hence, I will express it like this, [an] , [aa], [ii] to show that the vowel is long, and occupies two moras. The feature is attaching to the stem like this, [aaʳ], [uuʳ].

/əə/ +[+r]----->[əəʳ]  
/aa/ +[+r] ----->[aaʳ]  
/uu/ +[+r] ----->[uuʳ]  
/əj/ + [ +r]----->[əəʳ]  
/ən/ + [ +r]----->[əəʳ]  
/an/ + [ +r] ----->[aaʳ]  
/aŋ/ + [ +r]----->[ããʳ]  
/əŋ/ +[+r] -----> [ə̃ə̃ʳ]  
/uŋ/ + [ +r] -----> [ũũʳ]  
/ø/ + [ +r]----->[əəʳ]  
/y/ + [ +r] ----->[yəəʳ]  
/yn/ + [ +r] ----->[yəəʳ]  
/i/ + [ +r]-----> [jəəʳ]  
/in/ + [ +r] -----> [jəəʳ]  
/iŋ/ + [ +r]-----> [jə̃ə̃ʳ]

Then we can notice that the retroflex suffix is attached to the stem in the final position. With the data,

/əə/ +[+r]----->[əəʳ]  
/aa/ +[+r] ----->[aaʳ]  
/uu/ +[+r] ----->[uuʳ]

the retroflex feature is quitting as a floating feature and associated with a mora. Therefore, the retroflex suffix should be always associated with a mora. And the constraint should be

Parse-[+r]

the retroflex suffix should be parsed into the nearest segments in syllables.

This constraint is brought forward to make sure that there is no longer floating feature and the retroflex feature is attached in nearest segment of the syllable. And in the same time, we should have a faithfulness constraint to prevent the change of the floating feature.

IDENT-IO[+r]

The retroflex feature has to preserve its own floating feature in the input and the output.

The two constraints interact with each other to make sure that the retroflex suffix is associated with the final mora. As to the ranking, the markedness constraint should be higher ranked, because the floating feature should be attached to the stem in the first place. Henceforth,

Parse-[+r] >> IDENT-IO[+r]

and the tableau is as below,

/əə/ +[+r]----->/əəʳ/

Input: /əə/ +[+r]	Parse-[+r]	IDENT-IO[+r]
→ [əəʳ]		*
[əə]+[+r]	*!	

The first candidate is the optimal one, due to that the floating feature has to be attached to the stem. Although the second candidate is more faithful, it violates that the retroflex suffix should not be a floating feature. Then another candidate can also be an optimal one, [əʳə]. Therefore, we have to rule out the potential one.

The tableau will be like this,

/əə/ +[+r]----->/əəʳ/

Input: /əə/ +[+r]	Parse-[+r]	IDENT-IO[+r]
→ [əəʳ]		*
[əə]+[+r]	*!	
[əʳə]	*!	

To the ranking of the tableau, the markedness constraints will be higher ranked than the faithfulness constraint. The first candidate is the optimal one, although it violates a faithfulness constraint. As to the other two candidates, they all fatally violate the markedness constraint Parse-[+r] and are ruled out. Then we turn to the data,

/əj/+ [+r]----->[əəʳ]  
 /ən/+ [+r]----->[əəʳ]  
 /əw/+ [+r]----->[əəʳ]

The final consonants will be deleted and the nuclear vowel becomes a long vowel. And the retroflex floating feature is attached to the right side of the syllable. Thus, I propose that the retroflex suffix feature can't be linked with consonants.

The constraint is proposed by Ma(2001),

\*r/C: Retroflex feature is not compatible with a consonantal segment.

The constraint is to avoid the floating feature to be attached to the final coda. And the faithfulness constraint which prevents deletions of the final consonants.

MAX-IO

Correspondent segments in the input should be preserved in the output (Kager, 1999).

The tableau is as below,

/ən/ + [+r] -----> [əɳʳ]

Input: /ən/ + [+r]	Parse- [+r]	*r/C	IDENT-IO [+r]	MAX-IO
→ [əɳʳ]			*	*
[əə] + [+r]	*!			*
[əʳə]	*!		*	*
[ənʳ]		*!	*	
[əʳn]	*!		*	

The markedness constraints are higher ranked than the faithfulness constraints. Hence, the second candidate violates the constraint that requires no floating feature and is kicked out. The third and the fifth candidates don't follow the rule that the retroflex suffix should be parsed to the nearest segment of the syllable, so they are out, too. The fourth candidate is fatally violating the constraint that forbids the retroflex suffix attaching to the consonants. So far the candidates which violate the markedness constraints are all out. Henceforth, the first candidate is the optimal one, although it violates the two faithfulness constraints IDENT-IO [+r] and MAX-IO. And there arises another problem that is another candidate [əʳ] may be the best candidate as well. Hence, we can add other constraints to prevent this candidate to be the optimal one.

MAX-μ-IO

The moras in the input have correspondence in the output.

DEP-μ-IO

The moras in the output have correspondence in the input (Kager, 1999).

The two constraints should be higher ranked than MAX-IO and IDENT-IO [+r] in order to make sure that there are only two moras in the rhyme.

Input: /ən/ + [+r]	Parse- [+r]	*r/C	MAX-μ-IO	DEP- μ-IO	IDENT-IO [+r]	MAX-IO
→ [əɳʳ]					*	*
[əə] + [+r]	*!					*
[əʳə]	*!				*	*
[ənʳ]		*!			*	
[əʳn]	*!				*	
[əʳ]			*!		*	*
[əəəʳ]				*!	*	*

In the tableau, the second candidate is out because it violates the constraint that the retroflex feature should be attached to the stem. The third and the fifth candidates are not following the rule that the retroflex suffix should be parsed to the nearest segment of the syllable. Thus, they are kicked out. And the fourth candidate is fatally violating the constraint that retroflex suffix should not be affiliated with a consonant. As to the other two candidates, the sixth and the seventh are not the optimal ones, because they change the number of their moras. Therefore, the optimal one is the first candidate, which has a deletion of the final consonant and a retroflex suffix attaching to the final mora. Then we can see that from the data below,

/ø/+ [+r]----->[əøʳ]  
 /y/+ [+r] ----->[ɥəøʳ]  
 /yn/+ [+r] ----->[ɥəøʳ]  
 /i/ + [+r]----->[jəøʳ]  
 /in/+ [+r] ----->[jəøʳ]

The high front vowel becomes a pre-nuclear glide and the insertion of a retroflex vowel occurs. And another candidate is also competitive with the optimal candidate, that is [iəʳ]. Hence, as we have rule out the competitive candidate. As we have propose that the vowels in the rhyme part have to have dorsal feature, we will apply it here, too.

\*<sub>r</sub>/I

The retroflex suffix can't be attached to the high vowels (Ma, 2001).

Input: /in/ +[+r]	Parse-[+r]	* <sub>r</sub> /C	* <sub>r</sub> /I	MAX-μ-IO	DEP-μ-IO	IDENT-IO[+r]	MAX-IO
→	[jəøʳ]					*	*
	[jəʳ]			*!		*	*
	[jəʳn]	*!				*	
	[jənʳ]		*!			*	
	[iʳn]	*!	*			*	
	[iəʳ]		*!			*	*
	[əʳ]			*!		*	**
	[əøʳ]					*	**!

In the tableau, we can see that the third candidate and the fifth candidate violate the constraint that the retroflex suffix should be parsed to the nearest segment of the syllable and are ruled out. Then the fourth candidate is the one has a retroflex suffix affiliated with a final consonant, so it is violating the constraint \*<sub>r</sub>/C. The competitive candidate is kicked out because it fatally violates the constraint which demands retroflex suffix not to be attached to high vowels. As to the other two candidates, the second and the seventh, they have deleted one mora in the rhyme part so they are out. The eighth candidate has deleted one more segment than the first one, so it is not suitable to be the optimal candidate. Therefore, the first candidate is the optimal one although it violates IDENT-IO[+r] and MAX-IO. Then we can turn to the data with a velar nasal and an alveolar nasal in the coda.

/aŋ/ + [+r] ----->[ããʳ]  
 /əŋ/ + [+r] -----> [ɛ̃ɛʳ]  
 /uŋ/ + [+r] -----> [ũũʳ]  
 /ən/ + [+r] ----->[əəʳ]  
 /an/ + [+r] ----->[ɑɑʳ]  
 /un/ + [+r] ----->[uuʳ]

The nasalization of the nuclear vowel is always the hot issue in the retroflex suffixation. The alveolar nasal in the coda position gets deletion and then the retroflex feature is attached to the nuclear vowel. It is also worthy of mentioning that the nuclear vowel becomes a long vowel. As to the velar nasal, it gets omitted as well, however, it first nasalizes the nuclear vowel and then gets deletion. The different behaviors of the two final nasals constitute a phenomenon of opacity.

As to distinguish the differ between the behaviors of the velar nasal and the alveolar nasal, the constraint should be

\*V<sub>oral</sub>N

Before a tautosyllabic nasal, vowels must not be oral.

This constraint is also adopted in English, as many languages containing the nasalization of the nuclear vowel as well. The vowel anticipates the nasality of the following stop, a preferred state of affairs from the view point of perception and articulation (Cohn, 1990). The markedness constraint as mentioned in Kager (1999:28) is context-sensitive, since it states a connection between the nasality of a vowel and a nasal stop in its context. Here, in Beijing dialect, it is more natural to have a nasal vowel in front of [ŋ] than in front of [n]. Therefore, the constraint will be divided into \*V<sub>oralŋ</sub> and \*V<sub>oraln</sub>. In respect to the markedness constraint, the faithfulness constraint is as below,

IDENT-IO[nasal]

Correspondence segments in input and output have identical values for [nasal].

Thus, the faithfulness constraint is to make sure that segments don't insert the feature of [nasal] and don't delete it, either. Kager (1999:29) indicates that when markedness dominates faithfulness, the language achieves outputs that are minimally marked, at the expense of a neutralization of lexical contrasts. But when faithfulness dominates markedness, the language makes the reverse choice, realizing its input contrasts as the expense of output markedness.

Markedness>>Faithfulness Lexical contrasts are neutralized

Faithfulness>>Markedness Lexical contrasts are expressed

In English, the lexical contrast is neutralized, with respect to the hierarchy of the markedness constraint overranging the faithfulness constraint. However, in Mandarin, the two nasals tend to be varied in ways. To the alveolar nasal, it intends to have a lexical contrast expressed. The preservation of the identical nasal feature is more important than the nasalization of the nuclear vowel. In comparison, the velar nasal prefers to neutralize the lexical contrasts by putting the markedness constraint in the first place.

/an/ + [+r] ----->/ɑɑʳ/

Input:/an/ + [+r]	IDENT-IO[nasal]	*V <sub>oraln</sub>
→ [ɑɑʳ]		
[ããʳ]	*!	

/an/ + [+r] ----->/ãã/

Input: /an/ + [+r]	*Voralŋ	IDENT-IO[nasal]
[ααʳ]		
→ * [ããʳ]		*!

The two tableaux account for how different the nasals prefer the lexical contrast. Therefore, the hierarchy is \*Voralŋ >> IDENT-IO[nasal] >> \*Voraln. The variable behaviors of two nasals will lead to a residual problem, the opacity. The following tableaux will be given,

/an/ + [+r] ----->/ααʳ/

Input: /an/ + [+r]	Parse-[+r]	*r/C	*r/l	MAX- μ-IO	DEP- μ-IO	IDENT -IO[+r]	MAX -IO	IDENT -IO[nasal]	*Voraln
→ [ααʳ]						*	*		
[αʳ]				*!		*	*		
[αʳn]	*!					*			*
[αnʳ]		*!				*			*
[ããʳ]						*	*	*!	
[ãʳn]	*!					*		*	*

The third and the sixth candidates in the tableau first violate the constraint that requires the retroflex floating feature to be parsed to the nearest segment of the syllable. Then the fourth is less optimal due to that the retroflex suffix is attached to a consonant, which violates \*r/C. After that, the second candidate is ruled out as well, because it deletes one mora and violates MAX-μ-IO. Therefore, two competitive candidates are left to be chosen, the first and the fifth. Since the faithfulness constraint is higher ranked than the markedness constraint, the optimal candidate is the first one.

/an/ + [+r] ----->/ãã/

Input: /an/ + [+r]	Parse-[+r]	*r/C	*r/l	MAX- μ-IO	DEP- μ-IO	*Voralŋ	IDENT -IO[+r]	MAX -IO	IDENT -IO[nasal]
→ * [ααʳ]							*	*	
[αʳ]				*!			*	*	
[αʳŋ]	*!					*	*		
[αŋʳ]		*!					*		
[ããʳ]							*	*	*!
[ãʳŋ]	*!						*		*

In the second tableau, all other candidates are fatally violating the markedness constraints and out as the same as in the first tableau. There are only two candidates [ααʳ] and [ããʳ] competing with each other. In contrast to the alveolar nasal, the velar nasal prefers to have a nasalized vowel in the outcome.

Thus, it chooses the transparent candidate in the tableau, since the optimal one is an opaque one. In the first tableau, there comes the faithfulness constraint IDENT-IO[nasal] first and to keep the vowel identical as before. In the second, the markedness constraint runs in front of the faithfulness one. And It neutralizes the lexical contrast. The only difference is that the ranking IDENT-IO[nasal]>> \*V<sub>oraln</sub> is preferred by the alveolar nasal, whereas the opposite to the velar nasal \*V<sub>oralŋ</sub>>>IDENT-IO[nasal] .

Therefore, the hierarchy of all constraints of retroflex suffixation is as below,

Parse-[+r], \*r/C, \*r/I >> MAX- $\mu$ -IO, DEP- $\mu$ -IO>> \*V<sub>oralŋ</sub>>>IDENT-IO[+r], MAX-IO, IDENT-IO[nasal] >>\*V<sub>oraln</sub>

This phenomenon of the retroflex suffixation is a phonological opacity. It happens in two forms, the non-surface true and the non-surface apparent (McCarthy, 1999),

Non-surface-true:

Some generations G appears to play an active role in some language L, but there are surface forms of L (apart from lexical exceptions) that violates G.

Non-surface-apparent:

Some generations G shapes the surface form F, but the conditions that make G applicable are not visible in F.

As we have mentioned before, the retroflex suffixation prefers first application. Thus, it is non-surface-true.

### 3.2. The OT-CC introduction

In order to make a better account for the phenomenon of the retroflex suffixation, in the following paragraphs, the OT-CC is applied to account for the derivation of the phenomenon. OT-CC is advanced based on the limitation of the Classic OT by McCarthy (2006, 2007). The best part of OT-CC is that it contains the derivations of the whole process. The definition of the candidates will be modified as the chains of the forms that link the input and output by minimal phonological differences (McCarthy, 2007).

Cited by McCarthy (2007),

The definition of Candidate Chains

A candidate chain associated with an input /in/ in a language with the constraint hierarchy  $H$ , is an ordered  $n$ -tuple of forms  $C = \langle f_0, f_1, \dots, f_n \rangle$  that meets the following conditions:

-Faithful initial form:  $f_0$  is a faithful parse of /in/. (Specifically, it's the faithful parse of /in/ that's most harmonic according to  $H$ .)

-Gradual divergence: In every pair of immediately successive forms in  $C$ ,  $\langle \dots, f_i, f_{i+1}, \dots \rangle$  ( $0 \leq i < n$ ),  $f_{i+1}$  has all of  $f_i$ 's unfaithful mappings, plus one.

-Harmonic improvement: In every pair of immediately successive forms in  $C$ ,  $\langle \dots, f_i, f_{i+1}, \dots \rangle$  ( $0 \leq i < n$ ),  $f_{i+1}$  is more harmonic than  $f_i$  according to  $EVAL_H$ .

Hence, we will notice that the first candidate should be the one identical to the one as an input, because this is the most faithful form among other candidates. And the optimal candidate will be the last one. The  $f_{i+1}$  is less faithful than  $f_i$ . The lower ranked faithfulness constraint which is violated is to satisfy the higher ranked markedness constraint. Then the output is well-formed. The example I will cite from McCarthy (2007),

With a hypothetical ranking,

a) NO-CODA >> MAX >> DEP >> \*VCVCLSV >> IDENT(voice)

NO-CODA: no consonantal finals

MAX: no deletion

DEP: no insertion

\*VCVCLSV: no voiceless consonants between two vowels.

IDENT(voice): no change in voicing

b) Some valid chains for input /pap/ under the grammar in (a).

<pap> Faithful parse.

<pap, pa.pə> Harmonically improving because NO-CODA >> DEP.

<pap, pa> Harmonically improving because NO-CODA >> MAX.

<pap, pa.pə, pa.bə> Harmonically improving because <pap, pap> is harmonically improving and \*VCVCLSV >> ID(voice).

c) Some invalid chains for input /pap/ under the grammar in (a).

\*\*<pap, pa.b> Final voicing is not harmonically improving under  $H_t$ .

\*\*<pap, pa.bə> Not gradually divergent.

As we can see, in Classic OT there are infinite candidates. However, in OT-CC, the candidates should be evaluated and valid. It explains well on phonological opacity and cut off the unvalid candidates. McCarthy (2007) gives us a chart to illustrate the relationship between GEN and EVAL $H_t$ .

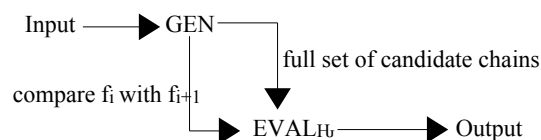

The benefit of having an evaluation is ruling out the infinite candidate. Therefore, we can have a more harmonic improvement. The  $H_t$  includes the faithfulness constraints and markedness constraints. Markedness constraints evaluate well-formedness of output structures, whereas faithfulness constraints penalize disparity between input and output (McCarthy, 2007). The Classic OT is preferring the transparent process, but OT-CC contains the intermediate process of opacity.

Candidate in OT-CC (McCarthy, 2007)

A candidate is an ordered 4-tuple (in, out, L-set, rLUMSeq),

“in” is the input

“out” is the output

“L-set” is a set of rLUMs from the “in” to “out”

rLUMSeq is a partial ordering on a subset of L-set.



Then recall our examples and put it in the Candidate in OT-CC,

- $\langle /pap/, pap, \emptyset, \emptyset \rangle$
- $\langle /pap/, pa.pə, DEP@4, \emptyset \rangle$
- $\langle /pap/, pa, MAX@3, \emptyset \rangle$
- $\langle /pap/, pa.bə, \{DEP@4, ID(voice)@3\}, \{\langle DEP@4, ID(voice)@3 \rangle\} \rangle$

And the markedness constraints evaluate “out”, while the faithfulness constraints evaluate the “in” to “out” relations encoded in the L-set. And the evaluation of rLUMSeq is the responsibility of PREC Constraints (McCarthy, 2007),

PREC(edence) constraints

PREC(A, B)

Let A' and B' stand for LUMs that add violations of the faithfulness constraints A and B, respectively.

Let cand=(in, out, L, rL)

- To any chain of the form  $\langle X, B', Y \rangle$ , if X does not contain A', assign a violation mark, and
- to any chain of the form  $\langle X, B', Y \rangle$ , if Y contains A', assign a violation mark.

PREC(A,B) is playing a crucial role in OT-CC for interpretation of the phonological opacity. It requires that every B-violating form be preceded and not followed by an A-violating form in the subset of the L-set.

And the metaconstraint on the ranking of PREC constraints

$B \gg \text{PREC}(A,B)$ : B must dominate PREC(A, B), for all faithfulness constraints A.

Hence, with the tool of the OT-CC, the opacity of the retroflex suffixation will be fully accounted for.

### 3.3. The OT-CC Account

Recall the hierarchy of the retroflex suffixation, which is peculiar for the velar nasal in coda, Parse-[+r], \*<sub>r</sub>/C, \*<sub>r</sub>/I >> MAX-μ-IO, DEP-μ-IO >> \*V<sub>oral</sub>η >> IDENT-IO[+r], MAX-IO, IDENT-IO[nasal] >> \*V<sub>oral</sub>n

Now we can adopt the candidate chains to figure out the valid candidates for the retroflex suffixation of [aŋ],

Valid chains for /aŋ/ + [+r]----->/ãã/,

- |  |  |
|--|--|
| a) $\langle aŋ.[+r] \rangle$                         | Faithful parse   |
| b) $\langle aŋ.[+r], aã.[+r] \rangle$                | Harmonically improving because of<br>* <sub>r</sub> /C >> MAX-IO             |
| c) $\langle aŋ.[+r], aã.[+r], aã^r \rangle$          | Harmonically improving because of<br>Parse-[+r] >> IDENT-IO[+r]              |
| d) $\langle aŋ.[+r], ãŋ.[+r] \rangle$                | Harmonically improving because of<br>*V <sub>oral</sub> η >> IDENT-IO[nasal] |
| e) $\langle aŋ.[+r], ãŋ.[+r], ãã.[+r] \rangle$       | Harmonically improving because of<br>* <sub>r</sub> /C >> MAX-IO             |
| f) $\langle aŋ.[+r], ãŋ.[+r], ãã.[+r], ãã^r \rangle$ | Harmonically improving because of<br>Parse-[+r] >> IDENT-IO[+r]              |

Through the valid candidate chains, the infinite candidates will be cut down to finite ones. The first candidate is totally faithful to the input. And the second candidate chain is adding a candidate that cuts off the final consonant and it is harmonically improved, because the ranking  $*r/C \gg \text{MAX-IO}$ . Then the candidate which has a retroflex suffix attached to the stem is added to the third candidate chains, because of the ranking  $\text{Parse-}[+r] \gg \text{IDENT-IO}[+r]$ . And so on and so forth, the final (f) contains the intended winner. The process declines the number of the candidates and valid the potential winner. And the bad candidates such as below will be ruled out,

Invalid chains for  $/a\eta/ + [+r]$ ----- $\rightarrow/\tilde{a}\tilde{a}r/$ ,

- a)  $** \langle \alpha\alpha^r \rangle$  No faithful parse in the first place
- b)  $** \langle a\eta.[+r], a\eta^r \rangle$  Constraint violation ( $*r/C$ ) is not harmonically improving.
- c)  $** \langle a\eta.[+r], \tilde{a}\tilde{a}^r \rangle$  Not gradually divergent

Therefore, the valid candidates are as below,

Candidates from (in, out, L-set, rLUMSeq)

- a)  $(/a\eta.[+r]/, a\eta.[+r], \emptyset, \emptyset)$
- b)  $(/a\eta.[+r]/, \alpha\alpha.[+r], \{\text{MAX-IO}@2\}, \emptyset)$
- c)  $(/a\eta.[+r]/, \alpha\alpha^r, \{\text{MAX-IO}@2, \text{IDENT-IO}[+r]@1\}, \{\langle \text{MAX-IO}@2, \text{IDENT-IO}[+r]@1 \rangle\})$
- d)  $(/a\eta.[+r]/, \tilde{a}\eta.[+r], \{\text{IDENT-IO}[\text{nasal}]@1\}, \emptyset)$
- e)  $(/a\eta.[+r]/, \tilde{a}\tilde{a}.[+r], \{\text{IDENT-IO}[\text{nasal}]@1, \text{MAX-IO}@2\}, \{\langle \text{IDENT-IO}[\text{nasal}]@1, \text{MAX-IO}@2 \rangle\})$
- f)  $(/a\eta.[+r]/, \tilde{a}\tilde{a}^r, \{\text{IDENT-IO}[\text{nasal}]@1, \text{MAX-IO}@2, \text{IDENT-IO}[+r]@1\}, \{\langle \text{IDENT-IO}[\text{nasal}]@1, \text{MAX-IO}@2, \text{IDENT-IO}[+r]@1 \rangle\})$

The candidate (f) is the output  $[\tilde{a}\tilde{a}^r]$ , and the same competitive candidate is the candidate (c)  $[\alpha\alpha^r]$ . The differ between the two candidate is that the candidate (c) is lacking of the violation of the  $\text{IDENT-IO}[\text{nasal}]$ . And in (c), there is missing the faithfulness constraint  $\text{IDENT-IO}[\text{nasal}]$  in the rLUMSeq to be preceded by the  $\text{MAX-IO}$  constraint. Then I propose that  $\text{PREC}(\text{IDENT-IO}[\text{nasal}], \text{MAX-IO})$ ,

$\text{PREC}(\text{IDENT-IO}[\text{nasal}], \text{MAX-IO})$

Let A' and B' stand for forms that add violations of the faithfulness constraints  $\text{IDENT-IO}[\text{nasal}]$  and  $\text{MAX-IO}$ , respectively.

To any chain of the form  $\langle X, B', Y \rangle$ , if X doesn't contain A', assign a violation mark.

To any chain of the form  $\langle X, B', Y \rangle$ , if Y contains A', assign a violation mark.

Or rather, if the chain is such as  $\langle X, B', Y \rangle$ , X contains a form which violates  $\text{IDENT-IO}[\text{nasal}]$ , there will be an asterisk to identify it. Also if Y contains a form that violates  $\text{IDENT-IO}[\text{nasal}]$ , there will be an asterisk as well. As in the  $\text{PREC}(A, B)$ , it demands the B-violating LUM being preceded and not followed by A-violating LUM. As to the metaconstraint on the ranking of  $\text{PREC}$  constraints,  $B \gg \text{PREC}(A, B)$ : B must dominate  $\text{PREC}(A, B)$ , for all faithfulness constraints A (McCarthy, 2007).

Hence, the hierarchy between the constraints and metaconstraints should be as such,  $\text{MAX-IO} \gg \text{PREC}(\text{IDENT}[\text{nasal}], \text{MAX-IO}) \gg \text{IDENT-IO}[\text{nasal}]$ ,

The tableau will be as below,

/aŋ/ + [+r]----->/ãã/

Input:/aŋ/ + [+r]	Parse-[+r]	*r/C	*r/I	MAX- μ-IO	DEP- μ-IO	*Voralŋ	MAX -IO	PREC(IDEN T-IO[nasal], MAX-IO)	IDENT -IO [nasal]	IDENT -IO[+r]
<aŋ.[+r]>	*!					*				
<aŋ.[+r], αα.[+r]> <MAX-IO@2>	*!						*	*		
<aŋ.[+r], αα.[+r], αα> <MAX-IO@2, IDENT- IO[+r]@1>							*	*!		*
<aŋ.[+r],ãŋ.[+r]> <IDENT- IO[nasal]@1>	*!								*	
<aŋ.[+r], ãŋ.[+r], ãã.[+r]> <IDENT- IO[nasal]@1, MAX-IO@2>	*!						*		*	
<aŋ.[+r], ãŋ.[+r], ãã.[+r],ãã> <IDENT- IO[nasal]@1, MAX-IO@2, IDENT- IO[+r]@1>							*		*	*

In the tableau, the first constraint is violated by four candidates, the first, the second, the fourth and the fifth. Then they are all kicked out. As to the other markedness constraints, they don't function much on selection of the best candidates, but they eliminate other bad candidates, such as [αα], [aŋ], [aŋ]. They are helpful to choose the valid candidates. The faithfulness constraints MAX-μ-IO and DEP- μ-IO help to kick out the candidates which delete the mora or insert an mora. Then there are two candidates left to compete with each other, the [αα] and [ãã]. The two candidates both violate the metaconstraint MAX-IO, because they delete the final consonant. The key to select the optimal candidate is the constraint PREC(IDENT-IO[nasal], MAX-IO). As we can see from the tableau, the candidate (c) has the LUMSeq <MAX@2, IDENT-IO[+r]>. The constraint PREC(IDENT-IO[nasal], MAX-IO) requires that in <X, B', Y>, X should contain A' and Y should not contain A'. In the candidate chain, the candidates are <aŋ.[+r], αα.[+r], αα >, X doesn't contain a form that violates IDENT-IO[nasal] and should be marked with an asterisk. Therefore, it is fatally violating the constraint PREC(IDENT-IO[nasal], MAX-IO) and out. The optimal candidate is the last one. The constraint PREC(IDENT-IO[nasal], MAX-IO) is functioning as an intermediate selection of the opaque candidate and it won't affect other candidates to be optimal, if the procedure of the retroflex suffixation is transparent. Then we apply the OT-CC to a transparent process of the retroflex suffix,

/əŋ/ + [+r]----->/əə/

The constraint hierarchy is as below,

Parse-[+r], \*r/C, \*r/I >> MAX-μ-IO, DEP-μ-IO >> \*V<sub>oralη</sub> >> IDENT-IO[+r], MAX-IO, IDENT-IO[nasal] >> \*V<sub>oraln</sub>

Valid candidate chains for /ən/ +[+r]----->/əəʔ/

- a) <ən.[+r]> Faithful parse
- b) <ən.[+r], əə.[+r]> Harmonically improving because of \*r/C >> MAX-IO
- c) <ən.[+r], əə.[+r], əəʔ> Harmonically improving because of Parse-[+r] >> IDENT-IO[+r]

Invalid candidate chains for /ən/ +[+r]----->/əəʔ/

- a) <ən.[+r], əəʔ> No faithful parse in the input
- b) <ən.[+r], əʔ> Constraints violation MAX-μ-IO
- c) <ən.[+r], əəʔ> More LUM at one time

Candidates from (in, out, L-set, rLUMSeq)

- a) (/ən.[+r]/, ən.[+r], Ø, Ø)
- b) (/ən.[+r]/, əə.[+r], {MAX-IO@2}, Ø)
- c) (/ən.[+r]/, əəʔ, {MAX-IO@2, IDENT-IO[+r]@1}, {< MAX-IO@2, IDENT-IO[+r]@1>})

Then we put the candidates in the tableau,

/ən/ +[+r]----->/əəʔ/										
Input:/ən/ +[+r]	Parse-[+r]	*r/C	*r/I	MAX-μ-IO	DEP-μ-IO	MAX-IO	PREC(IDENT-IO[nasal], MAX-IO)	IDENT-IO[nasal]	IDENT-IO[+r]	*V <sub>oraln</sub>
<ən.[+r]>	*!									*
<ən.[+r], əə.[+r]> <MAX-IO@2>	*!					*	*			
<ən.[+r], əə.[+r], əəʔ> <MAX-IO@2, IDENT-IO[+r]@1>✓						*	*		*	

In this tableau, the first and the second candidates violate the constraint which requires the retroflex suffix to be parsed into the nearest segment, thus they are kicked out. Then the third candidate is the optimal one. Although it violates the PREC(IDENT-IO[nasal], MAX-IO), because in <X, B', Y>, X doesn't contain a form that violates IDENT-IO[nasal]. To sum up, the OT-CC is also capable of dealing with the transparent process of the Classic OT and at the same time it can solve the opacity through an intermediate constraint.

## Chapter 4

# Phonological Analysis

### ---The Analysis with The Underlying Form of the Retroflex Suffix As a retroflex vowel

#### 4.1. The OT Account

Since the discussion of the retroflex suffix as a floating feature is done, we now turn to focus on the retroflex suffix as a retroflex vowel with a retroflex feature in the final mora. The expression of the retroflex suffix is [əʳ]. Ma (2001) has analyzed the procedure of the retroflex suffixation and taken the retroflex suffix as a mid-central vowel. The analysis of Ma (2001) is base on the sympathy theory. Here the data in the left is based on L.J.Wang (1991:112-128), and in the middle the rhymes with retroflex suffix are modified according to the hypothesis of the underlying forms of the vowels.

S	səʳ	<i>silk</i>
tʂ	tʂəʳ	<i>branch</i>
pei	pəʳ	<i>stele</i>
kən	kəʳ	<i>root</i>
kɿ	kɿʳ	<i>song</i>
p <sup>h</sup> o	p <sup>h</sup> oʳ	<i>old women</i>
pa	pɑʳ	<i>handle</i>
p <sup>h</sup> ai	p <sup>h</sup> ɑʳ	<i>card</i>
pan	pɑʳ	<i>plate</i>
tau	tɑʳ	<i>knife</i>
kou	koʳ	<i>hook</i>
kaŋ	kɑ̃ʳ	<i>jar</i>
təŋ	tɛ̃ʳ	<i>light</i>
tei	tɛjəʳ	<i>chicken</i>
tɛin	tɛjəʳ	<i>today</i>
tɛiɛ	tɛjəʳ	<i>street</i>
ia	jɑʳ	<i>tooth</i>
tɛian	tɛjɑʳ	<i>tine</i>
p <sup>h</sup> iau	p <sup>h</sup> jiɑʳ	<i>ticket</i>
tɛ <sup>h</sup> jou	tɛ <sup>h</sup> jiɑʳ	<i>ball</i>
liɑŋ	liɑ̃ʳ	<i>light</i>
iŋ	jɛ̃ʳ	<i>shadow</i>
kuei	kwəʳ	<i>cabinet</i>
kuən	kwəʳ	<i>stick</i>
uo	wɔʳ	<i>nest</i>
u	uʳ	<i>house</i>
hua	hwɑʳ	<i>flower</i>
kuai	kwɑʳ	<i>crutch</i>
kuan	kwɑʳ	<i>pot</i>
k <sup>h</sup> uaŋ	k <sup>h</sup> wɑ̃ʳ	<i>basket</i>
uəŋ	wɛ̃ʳ	<i>urn</i>

k <sup>h</sup> uŋ	k <sup>h</sup> ũr	<i>blank</i>
y	yə <sup>r</sup>	<i>fish</i>
tɛ <sup>h</sup> yn	tɛ <sup>h</sup> yə <sup>r</sup>	<i>skirt</i>
yɛ	yə <sup>r</sup>	<i>moon</i>
yan	yɑ <sup>r</sup>	<i>yard</i>
ɛiuŋ	ɛjũr	<i>bear</i>

The data is modified with the retroflex suffix as a retroflex mid-central vowel attaching to the stem. Instead of attached to the stem directly, the retroflex vowel first spreads its retroflex feature to the stem and get deletion of itself. Therefore, the procedure is different from that when the retroflex suffix is an approximant consonant or a floating feature. It involves an extra process that is the elimination of the retroflex vowel. Therefore, it concerns a multiple opacity. First of all, I will analyze it the same as above,

S + ə<sup>r</sup> ----->Sə<sup>r</sup>  
 tɕ + ə<sup>r</sup> ----->tɕə<sup>r</sup>  
 y + ə<sup>r</sup> ----->yə<sup>r</sup>  
 tɛ<sup>h</sup>yn+ə<sup>r</sup> -----> tɛ<sup>h</sup>yə<sup>r</sup>  
 tɛi+ə<sup>r</sup> -----> tɛjə<sup>r</sup>  
 tɛin+ə<sup>r</sup> -----> tɛjə<sup>r</sup>

The data can be summarized as below,

/Ø/+ /ə<sup>r</sup>/ -----> /ə<sup>r</sup>/  
 /y/ + /ə<sup>r</sup>/ -----> /yə<sup>r</sup>/  
 /yn/+ /ə<sup>r</sup>/ -----> /yə<sup>r</sup>/  
 /i/ + /ə<sup>r</sup>/ -----> /jə<sup>r</sup>/  
 /in/ + /ə<sup>r</sup>/ -----> /jə<sup>r</sup>/

This procedure of the retroflex suffixation is that the high front vowel becomes the pre-nuclear glide and then the retroflex vowel with a retroflex feature will be added to the stem as a nuclear vowel. Thus, the difference of the procedures between when the the underlying form of the retroflex suffix is a floating feature and when the underlying form of the retroflex suffix is a retroflex vowel with a retroflex feature is about whether there is an insertion of the retroflex vowel or a direct attachment of the retroflex vowel. The retroflex vowel is now as a nuclear vowel when the underlying form of the retroflex suffix is a segment. Here, we have to propose the constraints to eliminate the bad candidates, such as [iə<sup>r</sup>], [i<sup>r</sup>], [i<sup>r</sup>ə<sup>r</sup>], [ə<sup>r</sup>]. As we have analyzed that the high front vowels are not suitable to be retroflexed, then the constraint \*r/I will be proposed as before,

\*r/I

The retroflex suffix can't be attached to high vowels (Ma, 2001).

And the faithfulness constraint will be IDENT-IO[+r], which requires the retroflex feature to be identical between the input and the output. After that, there is one peculiar markedness constraint I propose,

\*V[ə<sup>r</sup>]

The vowel which is adjacent to a retroflex vowel can't be unretroflexed.

This constraint prevents the candidates such as [iə<sup>r</sup>]. And the last faithfulness constraint I propose is MAX-IO, which demand no deletion of the segments. The tableau is as below,

Input: /i/ + /əʳ/	*r/I	*V[əʳ]	IDENT-IO[+r]	MAX-IO
→ [jəʳ]				
[iəʳ]		*!		
[iʳ]	*!		*	
[iʳəʳ]	*!		*	
[əʳ]				*!

In this tableau, the third and the fourth candidates are ruled out because retroflex suffix can't be attached to high vowels. And the second candidate is fatally violating the constraint that forbids the vowels to be unretroflexed in the syllable in front of a retroflex vowel and kicked out. As to the other two candidates, the last one violates the requirement of no deletion and is no longer an optimal candidate. Thus, the optimal one is the first candidate with a direct attachment of the retroflex vowel and the high front vowel becoming a pre-nuclear glide. Then we turn to the data, /in/ + /əʳ/ -----> [jəʳ], the final consonant is deleted after the retroflex vowel is attached to the stem, \*r/C will be adopted here as well to eliminate the bad candidate [inʳ]. And as we can see from the candidate [inəʳ], the rhyme part has three moras. Here I propose that

\*3μ

No trimoraic syllables (Kager, 1999:268).

The constraint is to confirm the well-formedness of the syllable. The markedness constraint should be higher ranked to rule out the triple moras in one syllable. And the hierarchy of all constraints should be like this,

\*3μ, \*V[əʳ], \*r/C, \*r/I >> IDENT-IO[+r], MAX-IO

The markedness constraints should be over ranked than the faithfulness constraint. And the tableau is as below,

Input: /in/ + /əʳ/ -----> [jəʳ]	*r/I	*V[əʳ]	*r/C	*3μ	IDENT-IO[+r]	MAX-IO
→ [jəʳ]						*
[iəʳ]		*!				*
[iʳ]	*!				*	**
[iʳəʳ]	*!				*	*
[əʳ]						**!
[inəʳ]				*!		
[inʳ]			*!		*	*

In this tableau, the markedness constraints are higher to rule out the bad candidates. The first constraint which forbids that the retroflex suffix to be attached to the high vowels and kicks out the third and the fourth candidates.

Then the constraint which disallows unretroflexed vowel in front of a retroflex vowel in one syllable rules out the second candidate. Moreover, the constraint which forbids the retroflex suffix to be attached to a consonant makes the seventh candidate out of the competition. And the last markedness constraint rules out the sixth candidate, because the sixth candidate has three moras in one syllable. After that, there are two candidates left to compete with each other, the first one and the fifth one. Since the fifth candidate has deleted one more segment in the input and fails to match MAX-IO, the first candidate is the optimal one. Then we turn to another group of the data,

kɣ+ ə<sup>r</sup> -----> kɣ<sup>r</sup>  
 p<sup>h</sup>o+ə<sup>r</sup> -----> p<sup>h</sup>o<sup>r</sup>  
 pa + ə<sup>r</sup> -----> pɑ<sup>r</sup>  
 tɛjɛ+ə<sup>r</sup> -----> tɛjə<sup>r</sup>  
 ja+ə<sup>r</sup> -----> jɑ<sup>r</sup>  
 p<sup>h</sup>o+ə<sup>r</sup> -----> p<sup>h</sup>o<sup>r</sup>  
 wo+ə<sup>r</sup> -----> wo<sup>r</sup>  
 u +ə<sup>r</sup> -----> u<sup>r</sup>  
 hwa +ə<sup>r</sup> -----> hwɑ<sup>r</sup>  
 ye +ə<sup>r</sup> -----> yə<sup>r</sup>

Since we have indicated the underlying forms of the vowels, the following data can be list as such in a summary,

/ə/ +/ə<sup>r</sup>/ ----->/ə<sup>r</sup>/  
 /a/+/ə<sup>r</sup>/ ----->/ɑ<sup>r</sup>/  
 /u/ +/ə<sup>r</sup>/ ----->/u<sup>r</sup>/

## 4.2. The OT-CC Account

In these data, when the retroflex mid-central vowel is attached to the stem, the retroflex feature is affiliated with the rhyme part and the retroflex vowel gets itself deleted. In the second group of the data, the rules are as such,

Feature spreading: V--->V<sup>r</sup> / \_ +ə<sup>r</sup>  
 Retroflex vowel deletion: ə<sup>r</sup>----> Ø / \_ #

This process involves a single opacity. The application of the second rule will bleed the application of the first rule, or rather, the application of the second rule destroys the environment which the first rule can also apply in. Henceforth, the first rule will counterbleed the second rule in return. Here I will adopt the OT-CC as well to solve the problem. The potential candidates to compete with the best candidate are [uə<sup>r</sup>], [u], [u<sup>r</sup>ə<sup>r</sup>]. Here we need to propose another constraint which is adopted by Ma (2001),

ALIGN(stem, R, σ, R)

For every stem there must be some syllable such that the right edge of the stem matches the right edge of the syllable (Kager, 1999:119).

This constraint is the format of the Generalized Alignment (McCarthy and Prince, 1993a) which requires the asymmetrical relation between the stem and the syllable. This constraint will be helpful for select the optimal candidate.



And If we put this constraint in the tableau, concerning about the hierarchy above, the Alignment constraint should be ranked lower than the other markedness constraint but over ranked than MAX-IO. The tableau is indicating about the position of the Alignment constraint,

Input: /u/ +/əʔ/	ALIGN(stem, R, σ, R)	MAX-IO
[uəʔ]	*!	
→ [uʔ]		*

And then we put the Alignment constraint in the former tableau to figure out whether it is fit for our analysis or not,

Input: /in/ +/əʔ/	*r/I	*V[əʔ]	*r/C	*3μ	ALIGN(stem, R, σ, R)	IDENT-IO[+r]	MAX-IO
→ [jəʔ]					*		*
[iəʔ]		*!			*		*
[iʔ]	*!					*	**
[iʔəʔ]	*!				*	*	*
[əʔ]					*		**!
[inəʔ]				*!	*		
[inʔ]			*!			*	*

Then we can see that the Alignment constraint is fit into the tableau, and the hierarchy of all constraints has to be modified as,

\*3μ, \*V[əʔ], \*r/C, \*r/I >>ALIGN(stem, R, σ, R)>>IDENT-IO[+r], MAX-IO

According to the hierarchy that we have proposed, the valid candidate chains for retroflex suffixation,

Valid candidate chains for /u/ +/əʔ/ ----->[uʔ]

- <uəʔ> Faithful parse
- <uəʔ, u> Harmonically improving because of ALIGN(stem, R, σ, R)>>MAX-IO
- <uəʔ, uʔəʔ> Harmonically improving because of \*V[əʔ]>>IDENT-IO[+r]
- <uəʔ, uʔəʔ, uʔ> Harmonically improving because of ALIGN(stem, R, σ, R)>>MAX-IO

And the candidate from (in, out, L-set, rLUMSeq)

- (/uəʔ/, uəʔ, Ø, Ø)
- (/uəʔ/, u, {MAX-IO@2}, Ø)
- (/uəʔ/, uʔəʔ, {IDENT-IO[+r]@1}, Ø)
- (/uəʔ/, uʔ, {IDENT-IO[+r]@1, MAX-IO@2}, {< IDENT-IO[+r]@1, MAX-IO@2 >})

The winner of the competition is the last one, while the competitive candidate is the second. The differ between the two candidates are about the faithfulness constraint IDENT-IO[+r] and MAX-IO. Therefore, the constraint should be proposed as below,

PREC(IDENT-IO[+r], MAX-IO)

Let A' and B' stand for forms that add violations of the faithfulness constraints IDENT-IO[+r] and MAX-IO, respectively.

To any chain of the form <X, B', Y>, if X doesn't contain A', assign a violation mark.

To any chain of the form <X, B', Y>, if Y contains A', assign a violation mark.

This constraint is the key to rule out the competitive candidate. And the metaconstraint MAX-IO in this case should be ranked higher than the constraint PREC(IDENT-IO[+r], MAX-IO). The tableau is as such,

/u/ +/əʳ/ ----->[uʳ]

Input: /u/ +/əʳ/	*V[əʳ]	ALIGN(stem,R, σ, R)	MAX-IO	PREC(IDENT-IO[nasal], MAX-IO)	IDENT-IO[+r]
<uəʳ> <>	*!				
<uəʳ, u> <MAX-IO@2>			*	*!	
<uəʳ, uəʳ> <IDENT-IO[+r]@1>		*!			*
<uəʳ, uəʳ, u> √ <IDENT-IO[+r]@1, MAX-IO@2>			*		*

In this tableau, the first candidate violates the constraint that the vowel has to be retroflexed in front of a retroflex vowel with a retroflex feature and ruled out. After that, the third constraint fails to match the alignment constraint which requires the identification of the stem and the syllable on the right side. There are two candidate left to be the optimal one. The key to rule out the second candidate is the constraint PREC(IDENT-IO[+r], MAX-IO). As we can see, the B' is a violation form [u] and the X doesn't contain a form that violates the constraint IDENT-IO[+r], so that it is fatally out. And as to the fourth candidate, B' is a violation form [uʳ] and X contains a form that violates the constraint IDENT-IO[+r]. It is also worthy of mentioning that both candidates follow the requirement that Y doesn't contain a form that violates the constraint IDENT-IO[+r].

Now we turn to another group of the data,

- pej+ əʳ -----> pəʳ
- kən+əʳ -----> kəʳ
- p<sup>h</sup>aj +əʳ-----> p<sup>h</sup>əʳ
- pan+əʳ -----> pəʳ
- kow+əʳ -----> koʳ
- tejan +əʳ----->tejəʳ
- tə<sup>h</sup>jow+əʳ----->tə<sup>h</sup>joʳ
- kwej+əʳ ----->kwəʳ

kwən+əʳ ----->kwəʳ  
 kwaj +əʳ -----> kwɑʳ  
 kuan+əʳ -----> kuɑʳ  
 yan +əʳ ----->yɑʳ

And in a word, the data can be shorten as below,

/əj/+ /əʳ / -----> /əʳ/  
 /ən/+ /əʳ / -----> /əʳ/  
 /əw/+ /əʳ / -----> /əʳ/  
 /an/+ /əʳ / -----> /ɑʳ/  
 /aj/+ /əʳ / -----> /ɑʳ/

In the data above, the retroflex suffixation has complex procedures to add the retroflex feature in the stem. First of all, the final coda gets deletion and then the retroflex feature spreads its own feature to the stem vowel, at last the retroflex mid-central vowel gets itself deleted. The procedure involves single opacity as well. Thus, if we put the candidates in the tableau, we may get a wrong optimal one as below,

/an/+ /əʳ / -----> [ɑʳ]

Input: /an/ + /əʳ/	* <sub>r</sub> /I	*V[əʳ]	* <sub>r</sub> /C	* <sub>3</sub> μ	ALIGN(stem, R, σ, R)	IDENT-IO[+ <sub>r</sub> ]	MAX-IO
[ɑəʳ]		*!			*		*
[əʳ]					*!		**
[ɑʳ]						*!	**
[ɑʳəʳ]					*!	*	*
→ *[ɑ]							**
[anəʳ]				*!	*		
[anʳ]			*!			*	*

As we can see from the tableau, the markedness constraints rule out the candidates [ɑəʳ], [anʳ], [anəʳ]. Then the constraint ALIGN(stem, R, σ, R) kicks out the candidates [ɑʳəʳ] and [əʳ] which don't follow the rule that the right side of the stem matches the right side of the syllable. After that, we can see that the faithfulness constraint IDENT-IO[+<sub>r</sub>] rules out our intended winner [ɑʳ] and choose the wrong optimal one [ɑ]. Hence, the phonological opacity makes the Classic OT choose the wrong one. Instead of this tableau, another one will be proposed with candidate chains.

Recalling from the hierarchy of the constraints,

\*<sub>3</sub>μ, \*V[əʳ], \*<sub>r</sub>/C, \*<sub>r</sub>/I>>ALIGN(stem, R, σ, R)>>IDENT-IO[+<sub>r</sub>], MAX-IO

Valid candidate chains for /an/+ /əʳ / -----> [ɑʳ]

- a) <anəʳ> Faithful parse  
 b) <anəʳ, əʳ> Harmonically improving because of \*<sub>3</sub>μ>>MAX-IO  
 c) <anəʳ, əʳ, ɑ> Harmonically improving because of \*V[əʳ] >>MAX-IO

- d) < anəʔ, əəʔ, əʔəʔ > Harmonically improving because of  
\*V[əʔ]>>IDENT-IO[+r]
- e) < anəʔ, əəʔ, əʔəʔ, əʔ > Harmonically improving because of  
ALIGN(stem, R, σ, R)>>MAX-IO

Candidate from (in, out, L-set, rLUMSeq)

- a) (/anəʔ/, anəʔ, Ø, Ø)
- b) (/anəʔ/, əəʔ, {MAX-IO@2}, Ø)
- c) (/anəʔ/, ə, {MAX-IO@2, MAX-IO@3}, {< MAX-IO@2, MAX-IO@3>})
- d) (/anəʔ/, əʔəʔ, {MAX-IO@2, IDENT-IO[+r]@1}, {< MAX-IO@2, IDENT-IO[+r]@1>})
- e) (/anəʔ/, əʔ, {MAX-IO@2, IDENT-IO[+r]@1, MAX-IO@3}, {< MAX-IO@2, IDENT-IO[+r]@1, MAX-IO@3>})

As we can see from the data, the difference between the intended winner and the competitive one is due to the order of IDENT-IO[+r] and MAX-IO. Hence, PREC(IDENT-IO[+r], MAX-IO) is proposed to select the optimal candidate.

PREC(IDENT-IO[+r], MAX-IO)

Let A' and B' stands for forms that add violations of the faithfulness constraints IDENT-IO[+r] and MAX-IO, respectively.

To any chain of the form <X, B', Y>, if X doesn't contain A', assign a violation mark.

To any chain of the form <X, B', Y>, if Y contains A', assign a violation mark.

And the metaconstraint is MAX-IO which is higher ranked than PREC(IDENT-IO[+r], MAX-IO). The tableau is as below,

Input: /an/ +/əʔ/ -----> [əʔ]					
Input: /an/ +/əʔ/	*3μ	ALIGN(stem,R, σ, R)	MAX-IO	PREC(IDENT-IO[+r], MAX-IO)	IDENT-IO[+r]
<anəʔ> <>	*!				
< əəʔ, əəʔ > <MAX-IO@2>		*!	*		
<anəʔ, əəʔ, ə > <MAX-IO@2, MAX-IO@3>			**	*!	
<anəʔ, əʔəʔ > <MAX-IO@2, IDENT-IO[+r]@1>		*!	*		*
<anəʔ, əʔəʔ, ə > <MAX-IO@2, IDENT-IO[+r]@1, MAX-IO@3>			**		*

In this tableau, the first constraint rules out the most faithfulness candidate. Then alignment which demands that the right side of the stem to be matched with the right side of the syllable rules out the second and the fourth candidates. Although the third and the fifth candidate have deleted the final nasal, it doesn't affect the stem to be on the right side of the syllable. The key to rule out the second candidate is the PREC(IDENT-IO[+r], MAX-IO). The candidate [əʔ] is

B' and X doesn't contain a form that violates IDENT-IO[+r], thus it has an asterisk. As to the fifth candidate, X contains a form that violates IDENT-IO[+r]. Therefore, the fifth candidate is optimal one.

Then we should turn to the data of the final group,

kaŋ+ əʳ -----> kãʳ  
 təŋ+ əʳ -----> tãʳ  
 ljaŋ+ əʳ -----> ljãʳ  
 uəŋ+ əʳ -----> uãʳ  
 kʰwaŋ+ əʳ -----> kʰwãʳ  
 kʰuŋ+ əʳ -----> kʰũʳ  
 ɕiŋ+ əʳ -----> ɕiũʳ

After given the data, we can summarize it,

/aŋ/ + /əʳ/ -----> /ãʳ/  
 /əŋ/ + /əʳ/ -----> /ãʳ/  
 /uŋ/ + /əʳ/ -----> /ũʳ/

This procedure of the retroflex suffixation involves double opacity. First of all, the velar nasal nasalizes the vowel and gets deleted. After that, the retroflex suffix spreads its own feature to the nuclear vowel and then gets deleted as well. It is much more complex than the retroflex suffixation of the alveolar nasal in coda. The OT-CC is also applied here to solve the problem. The hierarchy of the constraints for the retroflex suffixation of the alveolar nasal in coda is as such,

\*3μ, \*V[əʳ], \*r/C, \*r/I>>ALIGN(stem, R, σ, R)>>IDENT-IO[+r], MAX-IO

As to the velar nasal, the constraint which has been mentioned before is as followed,

\*Voralŋ

The vowels in front of a velar nasal can't be oral.

And the faithfulness constraint is IDENT-IO[nasal] which requires the faithfulness of the nasal feature.

IDENT-IO[nasal]

Correspondence segments in input and output have identical values for [nasal].

The constraint \*Voralŋ should be ranked higher than Faithfulness constraints, because of the contextual markedness constraint >> faithfulness constraint (Kager, 1999). Then we put the candidates in the tableau with a Classic OT account.

/aŋ/ + /əʔ/ -----&gt; /ãʔ/

Input: /aŋ/ + /əʔ/	*V[əʔ]	*r/C	Parse-[+r]	*Voralŋ	ALIGN(stem , R, σ, R)	IDENT-IO[nasal]	IDENT-IO[+r]	MAX-IO
[αəʔ]	*!				*			*
[αʔəʔ]					*!		*	*
→ *[αʔ]							*	**
[ãʔəʔ]					*!	*	*	*
[ãʔ]						*!	*	**
[ãŋ]			*!			*	*	*
[ãʔəʔ]					*!	*	*	*
[ãŋ]		*!				*		*

First of all, the constraint \*V[əʔ] rules out the fatal candidate [αəʔ]. Secondly, the last candidate fails to match the constraint that forbids retroflex suffix attaching to a consonant and is kicked out. Then here we apply the constraint Parse-[+r] mentioned before to require that the retroflex suffix should be attached to the nearest segment of the syllable. It rules out the candidate [ãŋ]. Moreover, the alignment constraint kicks out the [αʔəʔ] and [ãʔəʔ], which violate the right side of the stem matching to the right side of the syllable. The markedness constraints rule out the other bad candidates and then there are two potential candidates to be the winner, [αʔ] and [ãʔ]. Finally the faithfulness constraint IDENT-IO[nasal] chooses the transparent candidate instead of the opaque one. The Classic OT fails to select the optimal one. Then we apply OT-CC instead,

The hierarchy of the constraints for retroflex suffixation of the velar nasal in coda,

Parse-[+r], \*V[əʔ], \*r/C, \*Voralŋ, \*3μ >> ALIGN(stem, R, σ, R) >> IDENT-IO[+r], MAX-IO, IDENT-IO[nasal]

Valid candidate chains for /aŋ/ + /əʔ/ -----> /ãʔ/

- a) < aŋəʔ > Faithful parse
- b) < aŋəʔ, αəʔ > Harmonically improving because of \*3μ >> MAX-IO
- c) < aŋəʔ, αəʔ, α > Harmonically improving because of ALIGN(stem, R, σ, R) >> MAX-IO
- d) < aŋəʔ, αəʔ, αʔəʔ > Harmonically improving because of \*V[əʔ] >> IDENT-IO[+r]
- e) < aŋəʔ, αəʔ, αʔəʔ, αʔ > Harmonically improving because of ALIGN(stem, R, σ, R) >> MAX-IO
- f) < aŋəʔ, ãŋəʔ > Harmonically improving because of \*Voralŋ >> IDENT-IO[nasal]
- g) < aŋəʔ, ãŋəʔ, ãəʔ > Harmonically improving because of \*3μ >> MAX-IO
- h) < aŋəʔ, ãŋəʔ, ãəʔ, ã > Harmonically improving because of ALIGN(stem, R, σ, R) >> MAX-IO

- i) < aŋəʳ, ǎŋəʳ, ǎəʳ, ǎʳəʳ > Harmonically improving because of  
\*V[əʳ] >>IDENT-IO[+r]
- j) < aŋəʳ, ǎŋəʳ, ǎəʳ, ǎʳəʳ, ǎʳ > Harmonically improving because of  
ALIGN(stem, R, σ, R) >>MAX-IO

Candidate from (in, out, L-set, rLUMSeq)

- a) (/aŋəʳ/, aŋəʳ, Ø, Ø)
- b) (/aŋəʳ/, əʳ, {MAX-IO@2}, Ø)
- c) (/aŋəʳ/, ə, {MAX-IO@2, MAX-IO@3}, {< MAX-IO@2, MAX-IO@3>})
- d) (/aŋəʳ/, əʳ, {MAX-IO@2, IDENT-IO[+r]@1}, {< MAX-IO@2, IDENT-IO[+r]@1 >})
- e) (/aŋəʳ/, əʳ, { MAX-IO@2, IDENT-IO[+r]@1, MAX-IO@3}, {< MAX-IO@2, IDENT-IO[+r]@1, MAX-IO@3>})
- f) (/aŋəʳ/, ǎŋəʳ, {IDENT-IO[nasal]@1}, Ø)
- g) (/aŋəʳ/, ǎəʳ, {IDENT-IO[nasal]@1, MAX-IO@2}, {< IDENT-IO[nasal]@1, MAX-IO@2>})
- h) (/aŋəʳ/, ǎ, {IDENT-IO[nasal]@1, MAX-IO@2, MAX-IO@3}, {< IDENT-IO[nasal]@1, MAX-IO@2, MAX-IO@3>})
- i) (/aŋəʳ/, ǎʳəʳ, {IDENT-IO[nasal]@1, MAX-IO@2, IDENT-IO[+r]@1}, {<IDENT-IO[nasal]@1, MAX-IO@2, IDENT-IO[+r]@1>})
- j) (/aŋəʳ/, ǎʳ, { IDENT-IO[nasal]@1, MAX-IO@2, IDENT-IO[+r]@1, MAX-IO@3}, {< IDENT-IO[nasal]@1, MAX-IO@2, IDENT-IO[+r]@1, MAX-IO@3>})

As we can see from the candidates (c), (e) and (h) , they are all competitive candidates to the optimal one. And the optimal one is (j). As we have analyzed before, there are only one potential candidate threatening the intended winner, however, here we have three potential candidates to be threatening the intended winner. Hence, here we have to propose two PREC constraints to rule the competitive candidates out. The subset of the L-set contains MAX-IO, IDENT-IO[nasal] and IDENT-IO[+r]. The key of ruling out the potential candidates is the order of the three constraints. The candidates have to first violate the IDENT-IO[nasal] ad IDENT-IO[+r] first, then the MAX-IO. Therefore, the PREC(IDENT-IO[+r], MAX-IO) and PREC(IDENT-IO[nasal], MAX-IO) should both be applied in the tableau. They are helpful with the selection of the intended winner. It is worthy of mentioning the metaconstraint MAX-IO should be ranked higher than both of them.

Then the hierarchy of the constraints will be as such,

MAX-IO >> PREC(IDENT-IO[+r], MAX-IO), PREC(IDENT-IO[nasal], MAX-IO) >> IDENT-IO[nasal], IDENT-IO[+r]

After that, given the former analysis of the hierarchy of relevant constraints, the hierarchy of the constraints for the retroflex suffixation with a velar nasal ending will be as below,

\*V[əʳ], \*r/C, Parse-[+r], \*Voralŋ >> ALIGN(stem, R, σ, R) >> MAX-IO >> PREC(IDENT-IO[+r], MAX-IO), PREC(IDENT-IO[nasal], MAX-IO) >> IDENT-IO[nasal], IDENT-IO[+r]

Thus, we apply the hierarchy in the tableau,

/aŋ/ + /ə/ -----> /ã/							
Input: /aŋ/ + /ə/	*3μ	ALIGN(stem, R, σ, R)	MAX-IO	PREC(IDENT-IO[nasal], MAX-IO)	PREC(IDENT-IO[+r], MAX-IO)	IDENT-IO[+r]	IDENT-IO[nasal]
<aŋə> <>	*!	*					
<aŋə, əə> <MAX-IO@2>		*!	*	*	*		
<aŋə, əə, ə> <MAX-IO@2, MAX-IO@3>			**	*!	*		
<aŋə, əə, əə> <MAX-IO@2, IDENT-IO[+r]@1>		*!	*	*	*	*	
<aŋə, əə, əə, ə> <MAX-IO@2, IDENT-IO[+r]@1, MAX-IO@3>			**	*!		*	
<aŋə, ãŋə> <IDENT-IO[nasal]@1>	*!	*			*		*
<aŋə, ãŋə, ãə> <IDENT-IO[nasal]@1, MAX-IO@2>		*!	*		*		*
<aŋə, ãŋə, ãə, ã> <IDENT-IO[nasal]@1, MAX-IO@2, MAX-IO@3>			**		*!		*
<aŋə, ãŋə, ãə, ãə> <IDENT-IO[nasal]@1, MAX-IO@2, IDENT-IO[+r]@1>		*!	*		*	*	*
<aŋə, ãŋə, ãə, ã> <IDENT-IO[nasal]@1, MAX-IO@2, IDENT-IO[+r]@1, MAX-IO@3>			**			*	*

As we can see from the tableau, the first constraints rule out [aŋə] and [ãŋə]. Then the alignment constraints rule out the other candidates and leaves the three potential candidates and the intended winner. After that, the three potential candidates and the intended winner all violate the metaconstraint MAX-IO twice. Then the [a] and [ə] violate the PREC(IDENT-IO[nasal], MAX-IO), because the X doesn't contain a form that violates IDENT-IO[nasal]. Then the candidate [ã] violates the PREC(IDENT-IO[+r], MAX-IO), because the X doesn't contain a form that violates IDENT-IO[+r]. Therefore, the winner is the last one [ã]. The double opacity is solved in retroflex suffixation of the velar nasal. Therefore, the derivation of the retroflex suffixation has been analyzed so far.



### 4.3. Feature Analysis

There is a modified version of the retroflex suffix, since we take the retroflex suffix as a mid-central vowel plus a retroflex feature instead of an approximant consonant. When the retroflex vowel plus a retroflex feature is attached to the stem, the retroflex feature is attached to the nuclear vowel of the syllable and the retroflex vowel gets itself deleted. Here I propose that the retroflex feature co-articulates with the retroflex vowel. Considered of the tongue as an active articulator, the retroflex involves a retroflex action of the tip of the tongue approaching to the hard palatal zone which is specified as a [apical] feature in the coronal place and also the dorsum of the tongue approaching to the soft palatal as a [dorsal] feature. Here I take the [apical] feature as equal as [retro] feature. As we see, the PSM assumes a restrictive grammar in which representational economy plays an important role and that every segment composed of more than one feature in a given language implies the presence of minimally different segments with a subset of those features, including segments composed of single features (Islam Youssff, 2010). The structure is now as such,

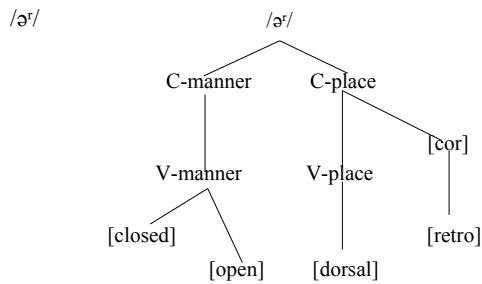

As we have indicated the vowels and the final consonants with a PSM feature specification, the tableau will be applied here as well,

			C-manner			V-manner		C-place		V-place	
			[closed]	[open]	[nasal]	[closed]	[open]	[cor]	[dor]	[cor]	[dor]
Stop	/n/	[n]	✓		✓			✓			
	/ŋ/	[ŋ]	✓		✓				✓		
approximant	/j/	[j]	✓			✓		✓			
	/w/	[w]	✓			✓			✓		
High vowel	/i/	[i][ɨ] [ɨ]				✓				✓	
	/y/	[y]				✓				✓	
	/u/	[u]				✓					✓
Mid vowel	[ə]	[e][ɛ] [ɤ][o] [ə]				✓	✓				
Low vowel	/a/	[a][ɑ]					✓				

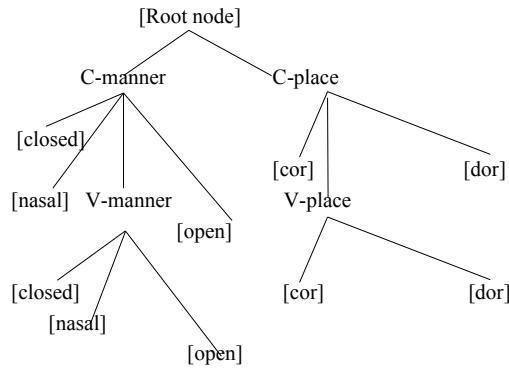

Here the first group of data is as below,

- /a/+/əʳ/ ----->[ɑʳ]
- /ə/+/əʳ/ ----->[əʳ]
- /u/+/əʳ/ ----->[uʳ]

Then we apply PSM feature geometry to see how the retroflex /əʳ/ fuses into the stem of a vowel ending,

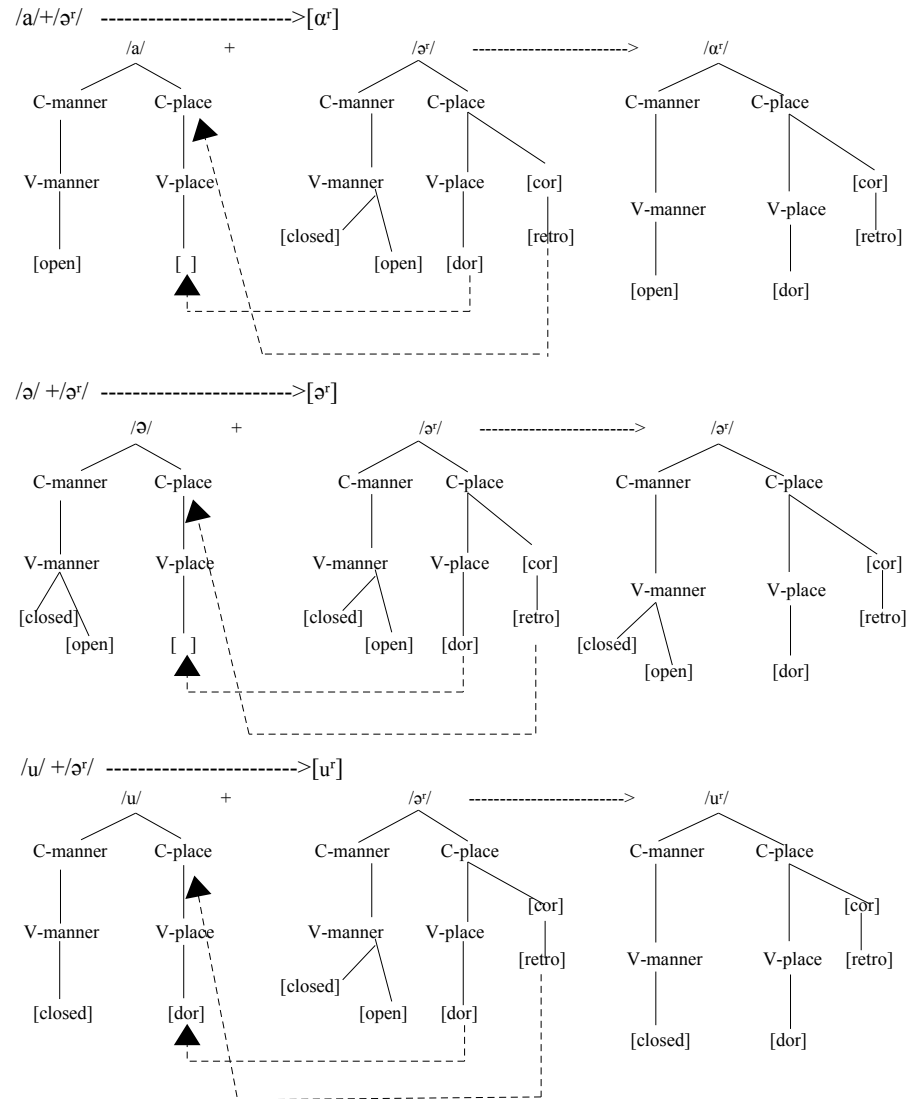

As we can see from the first group of data, the retroflex mid-central vowel first requires the nuclear vowel in the stem to have a dorsal feature and then it spreads its retroflex feature to the nuclear vowel in C-place. At last the retroflex vowel gets deleted by itself. The V-manners of the nuclear vowels are variable, however, they are irrelevant to our retroflex suffix attachment. If the vowel such as [u] has dorsal feature, it remains the same as before. If the vowel such as [a] doesn't have a dorsal feature, the retroflex suffix will spread its dorsal feature to the main vowel. The procedures of adding a retroflex suffix into different vowels in this group have a common that is the retroflex mid-vowel spreads its retroflex feature to the nuclear vowels in C-place.

Then we turn to the data which has a consonant ending in the stem,

- /əj/ + /əʳ/ -----> [əʳ]
- /ən/ + /əʳ/ -----> [əʳ]
- /əw/ + /əʳ/ -----> [əʳ]
- /an/ + /əʳ/ -----> [ɑʳ]
- /aj/ + /əʳ/ -----> [ɑʳ]

Here we apply PSM structure to indicate how the procedure is,

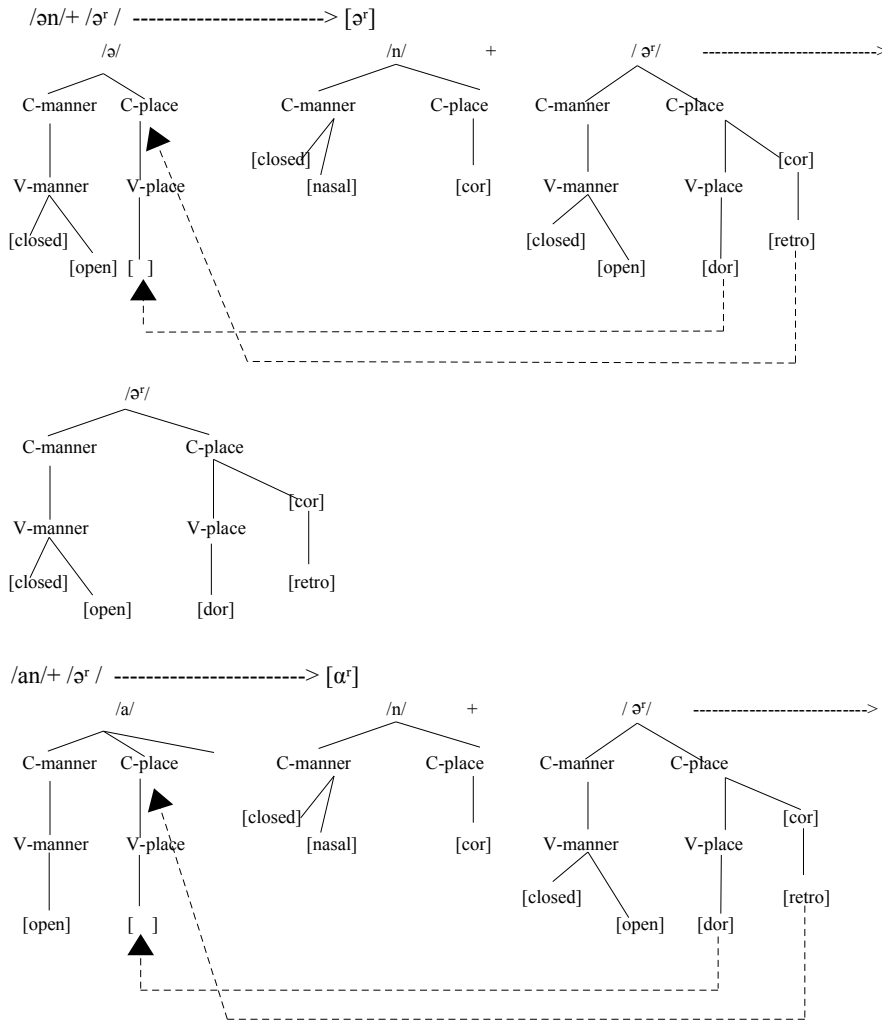

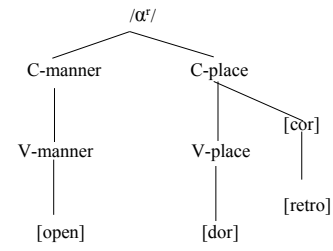

/əw/+ /əː/ -----> [əː]

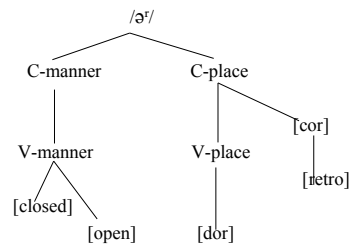
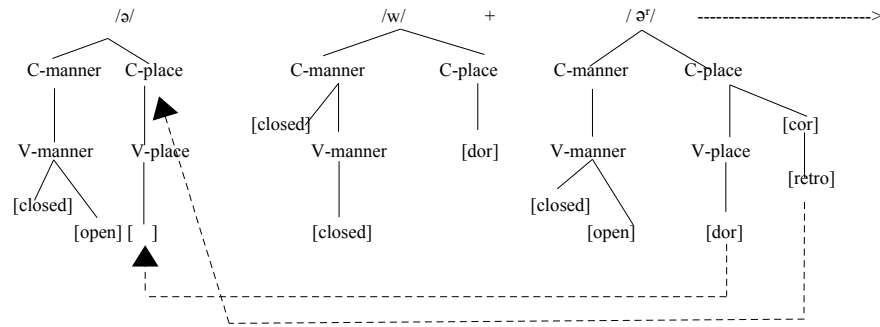

/aj/+ /əː/ -----> [ɑː]

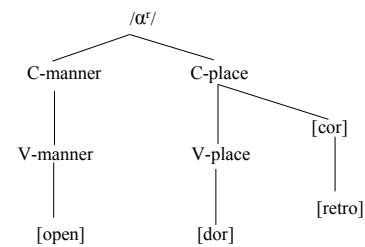
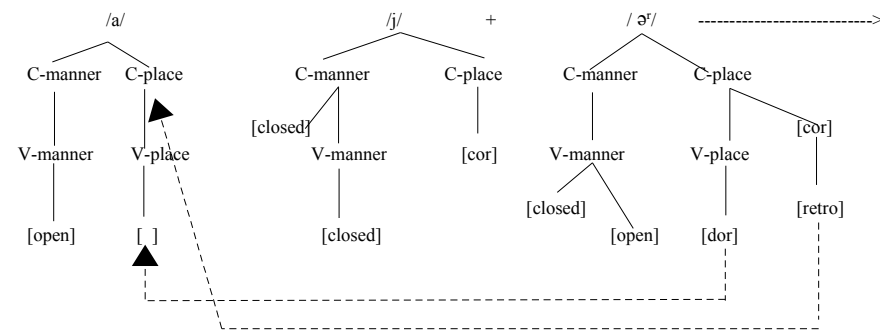

/əj/ + /əʳ/ -----> [əʳ]

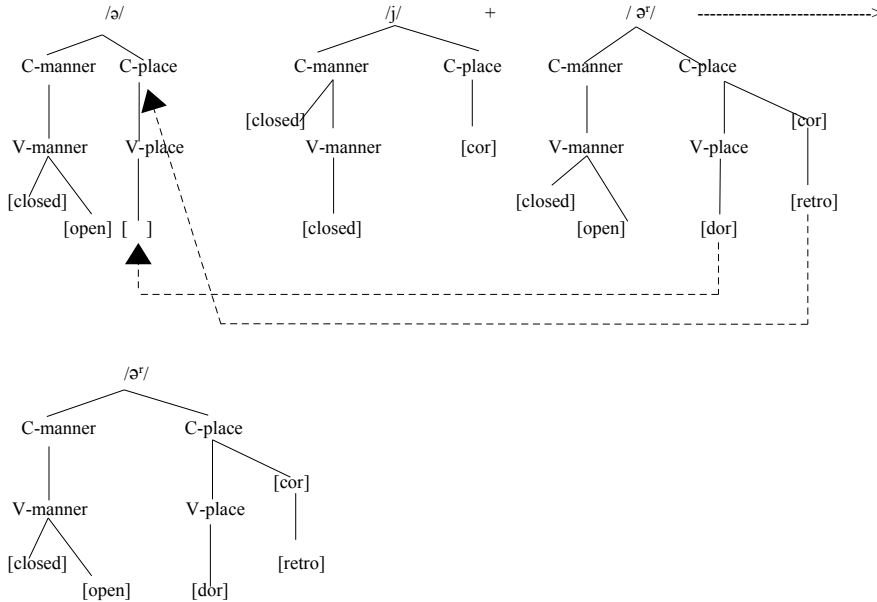

Among these structures, the retroflex vowel spreads its dorsal feature to the vowel [a] and [ə] which lack of specifying the dorsal feature. And the retroflex suffix also spreads its retroflex feature to the nuclear vowels across the consonants in C-place. The consonants in the finals are deleted.

Now the third group of data is as followed,

/aŋ/ + /əʳ/ -----> /ãʳ/  
 /əŋ/ + /əʳ/ -----> /ẽʳ/  
 /uŋ/ + /əʳ/ -----> /ũʳ/

The PSM structure will be applied to the data as well,

/aŋ/ + /əʳ/ -----> /ãʳ/

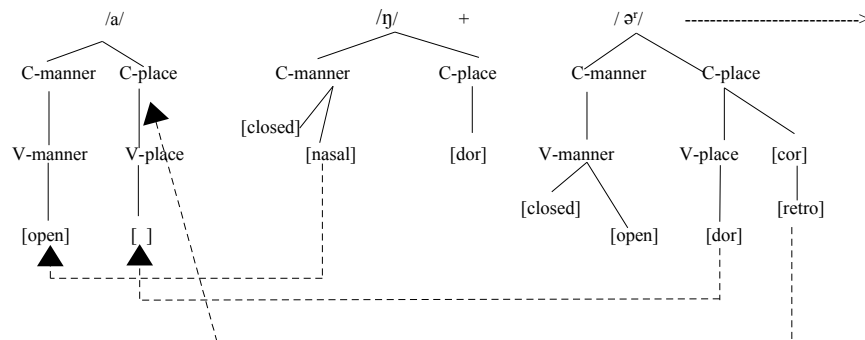

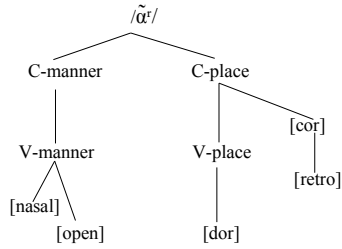

/əŋ/ + /əʀ/ -----> /ãr/

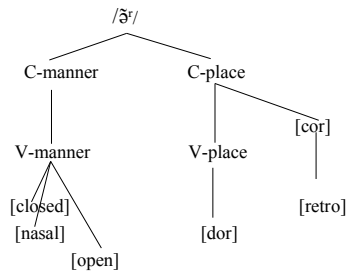
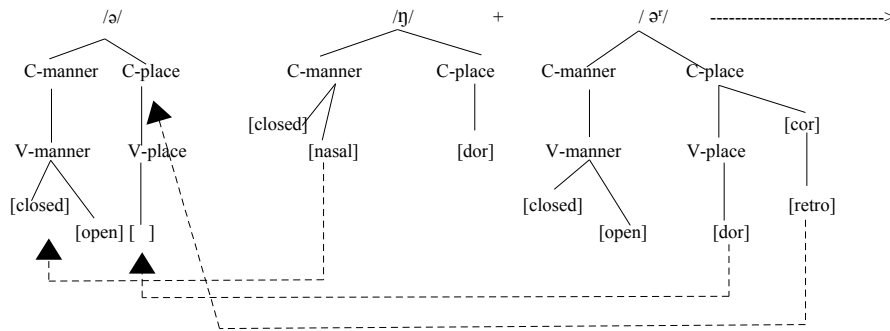

/uŋ/ + /əʀ/ -----> /ũr/

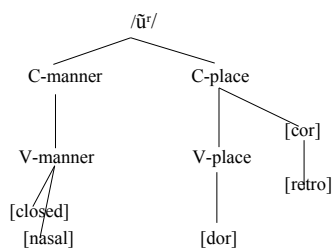
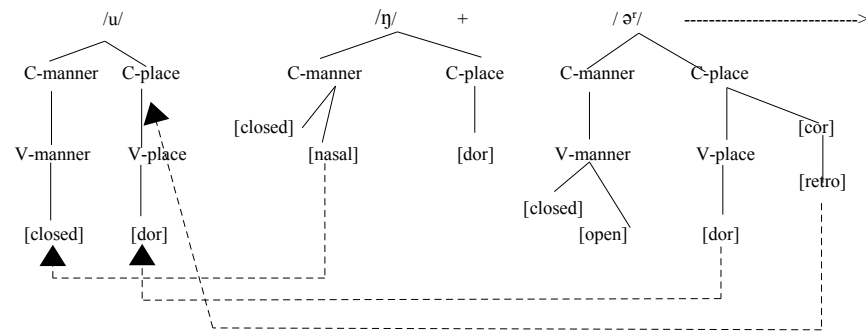

As we can see from the diagram, the retroflex vowel spreads its dorsal feature to the nuclear vowel and it spreads its retroflex feature as well. The different part from the last group is that the velar nasal spreads its nasal feature from C-manner to V-manner of the nuclear vowel. Recalling from the analysis when the retroflex suffix is an approximant consonant, I propose that the alveolar nasal [n] which has a coronal feature and a nasal feature will be deleted without spreading its nasal feature to the nuclear vowel, in contrast, the velar nasal which has a dorsal feature and a nasal feature will be deleted after it spreads its nasal feature to the nuclear vowel. The reason for this phenomenon is that I assume that the feature of the consonant with a dorsal feature is much more preserved than the one with a coronal feature. This proposal is due to the articulation and the perception of the consonants, however, there is no fix universal hierarchy about the two distinctive places of articulation. Therefore, this assumption is still debatable and needs further test.

The fourth group of the data is as below,

- /Ø/+ /əʳ/ -----> /əʳ/
- /y/ + /əʳ/ -----> /yəʳ/
- /yn/+ /əʳ/ -----> /yəʳ/
- /i/ + /əʳ/ -----> /jəʳ/
- /in/ + /əʳ/ -----> /jəʳ/
- /iŋ/ + /əʳ/ -----> /jəʳ/

a) /Ø/+ /əʳ/ -----> /əʳ/

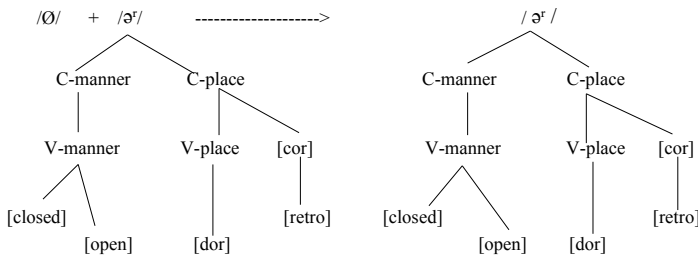

b) /y/ + /əʳ/ -----> /yəʳ/

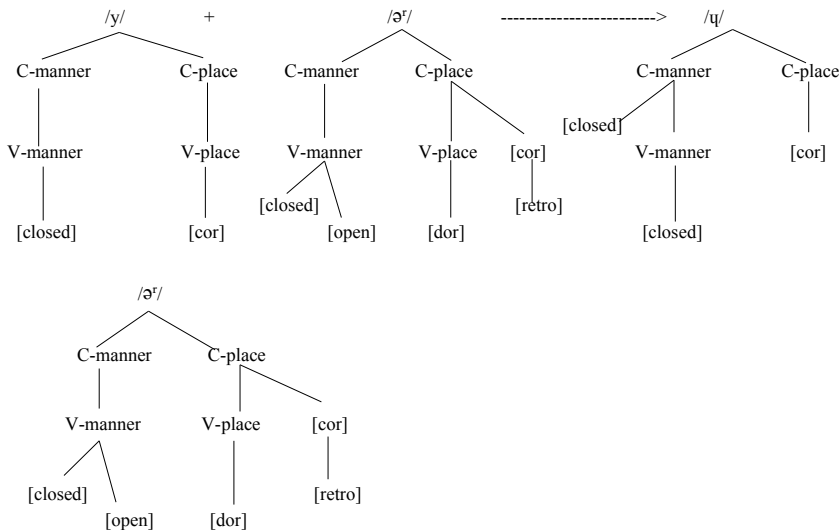

c) /yn/ + /əʔ/ -----> /yəʔ/

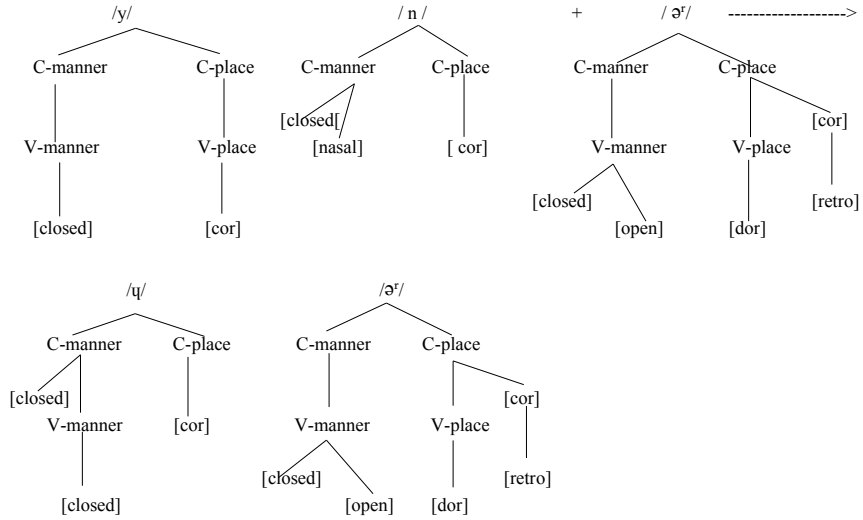

d) /i/ + /əʔ/ -----> /jəʔ/

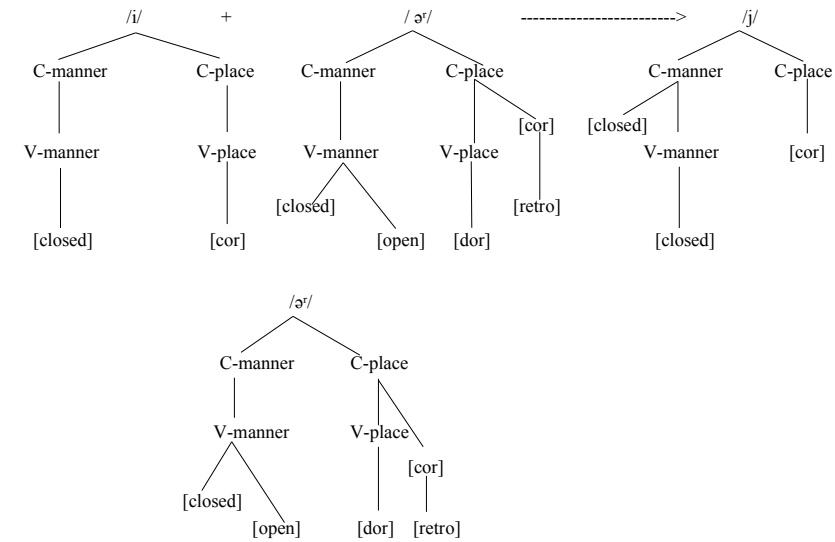

e) /in/ + /əʔ/ -----> /jəʔ/

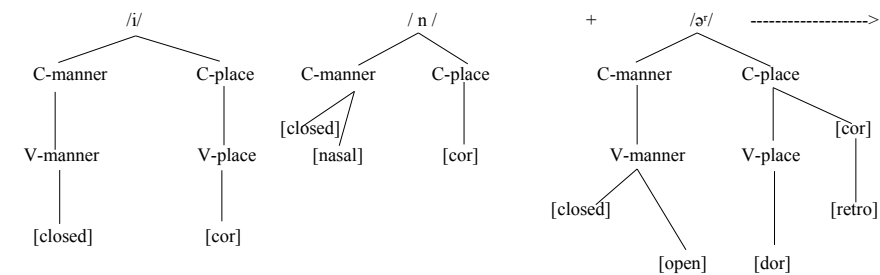



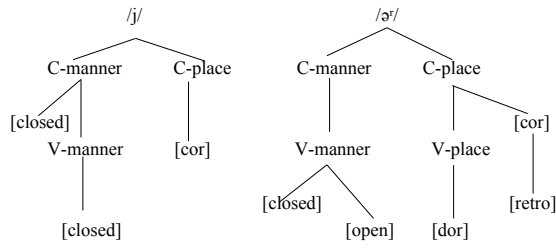

f) /iŋ/ + /ɤ/ -----> /jɤ/

I)

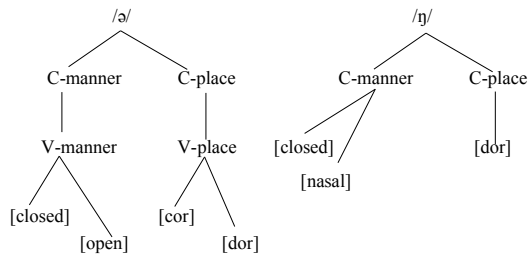
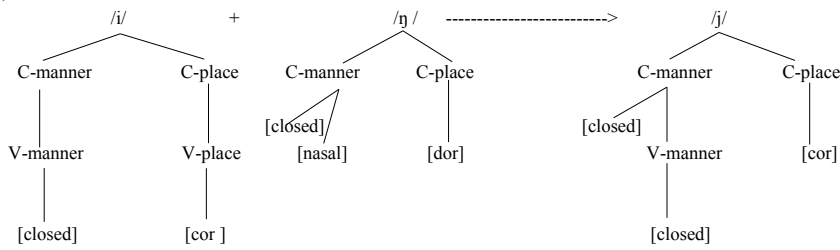

II)

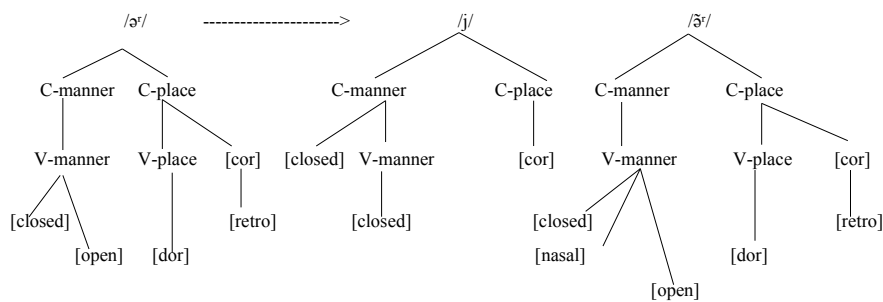
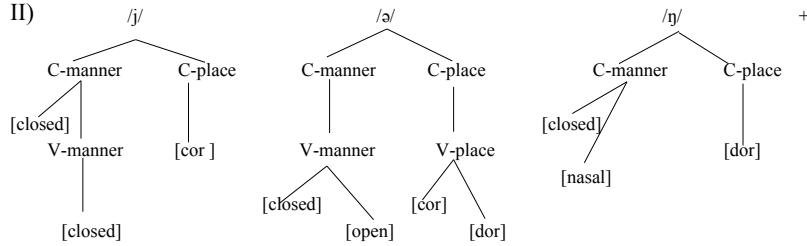

In the example (a), there is a vacancy in the vowel position and when the retroflex vowel with a retroflex feature is attached to the stem, the retroflex vowel with a retroflex vowel becomes a nuclear vowel. And in the examples (b) and (d), the high front vowel becomes a pre-nuclear glide, since it doesn't match the requirement to be retroflexed. Then in the examples (c) and (e), the final consonants are deleted and the high front vowel becomes a pre-nuclear glide. At the same time, the retroflex vowel with a retroflex feature becomes the nuclear vowel. This process contains an alveolar deletion. In the example (f), the procedure contains two steps, one of which is to alter itself as [jəŋ], and the other is to add a retroflex suffix in the stem. The first procedure is proposed by Wang (1963:22), who indicated that the [iŋ] is actually pronounced as [iəŋ]. Then the retroflex suffix spreads its retroflex feature to its nuclear vowel and the final velar nasal spreads its nasal feature to V-manner of the nuclear vowel. At last, the velar nasal and the retroflex suffix get deletion. Thus, when the vowel in the nuclear position is a high front vowel, the high front vowel becomes a pre-nuclear glide. And the retroflex vowel becomes a nuclear vowel with a retroflex feature. If there is an alveolar nasal in coda, the alveolar nasal gets itself deleted. If there is a velar nasal in coda, the velar nasal spreads its nasal feature to the nuclear vowel and then gets itself deleted.

Now we turn to the feature analysis of the phenomenon with Optimality Theory, in the first group of data,

/ø/+ /əʳ/ -----> /əʳ/  
 /y/ + /əʳ/ -----> /yəʳ/  
 /yn/+ /əʳ/ -----> /yəʳ/  
 /i/ + /əʳ/ -----> /jəʳ/  
 /in/ + /əʳ/ -----> /jəʳ/

The retroflex suffix becomes a nuclear vowel and the high front vowel becomes a pre-nuclear glide. Thus, the markedness constraint will be \*VV to avoid the diphthongs in one syllable. Here with a feature specification, the constraint will be modified as

\*V-mannerV-manner  
 Two V-manners are disallowed in one syllable.

And in contrast, the faithfulness constraint will be MAX-IOV-manner,

MAX-IOV-manner  
 There is no deletion of V-manner.

The tableau is as followed,

/i/ + /əʳ/ -----> /jəʳ/

Input:/i/+ /əʳ/	*V-mannerV-manner	MAX-IOV-manner
[iəʳ]	*!	
→ [jəʳ]		
[əʳ]		*!
[i]		*!

Then with a consideration of other candidates such as [iʳəʳ] and [iʳə], The tableau is as such,

/i/ + /əʳ/ -----> /jəʳ/

Input:/i/+ /əʳ/	*V-mannerV-manner	MAX-IOV-manner
[iəʳ]	*!	
→ [jəʳ]		
[əʳ]		*!
[iʳ]		*!
[iʳəʳ]	*!	
[iʳə]	*!	

In the tableau, the first constraint kicks out the first candidate, the fifth and the sixth, because of the violation of two V-manners together. In the end, the faithfulness constraint rules out the third and fourth candidates which delete their V-manners. The optimal candidate is the second one.

Then as we can see from the data, the candidate contains a final consonant in coda, such as /in/, [yn].

/in/ + /əʳ/ -----> /jəʳ/

/yn/+ /əʳ/ -----> /ɥəʳ/

Therefore, there will be

\*Consonant[+retro]

There must be no retroflex feature in consonants.

This constraint is modified according to the constraint \*r/C (Ma, 2001). The aim of the constraint is to prevent the retroflex feature to be attached to a consonant. And the faithfulness constraint is MAX-IOC-manner,

MAX-IOC-manner

There is no deletion of C-manner.

The hierarchy of two constraints is \*Consonant[+retro] >> MAX-IOC-manner, because the priority is to forbid the retroflex suffix to be attached to the consonants. And there should be another markedness constraint to rule out the candidate that has three moras [inəʳ]. The constraint will be

\*V-mannerC-mannerV-manner

There is no such three manners in one syllable.

Then we put the constraints to the tableau,

/in/ + /əʳ/ -----> /jəʳ/

Input:/in/+əʳ/	*V-manner V-manner	*Consonant [+retro]	*V-manner C-manner V-manner	MAX-IO V-manner	MAX-IO C-manner
[iəʳ]	*!				*
→ [jəʳ]					*
[əʳ]				*!	*
[i]				*!	*
[iʳəʳ]	*!				*
[iʳə]	*!				*
[inʳ]		*!		*	
[inəʳ]			*!		

In the tableau, the first constraint that forbids two manners kicks out the first candidate, the fifth and the sixth candidates. After that, the second constraint rules out the seventh candidate, because the retroflex feature can't be linked to a consonant. The last markedness constraint kicks out the candidate with V-mannerC-mannerV-manner together. As to the faithfulness constraint MAX-IOV-manner, it rules out the third and the fourth candidates which have deleted V-manners. In the end, the optimal candidate is the second, although it deletes one final consonant.

Now, we turn to the data,

/a/+əʳ/ ----->[aʳ]

/ə/+əʳ/ ----->[əʳ]

/u/+əʳ/ ----->[uʳ]

This procedure contains a single opacity as mentioned before. The the markedness constraint is

Vowel[+retro]

Vowels must have the retroflex feature.

And the faithfulness constraint is IDEN-IO[+retro],

IDENT-IO[+retro]

Segments have identical retroflex feature in the input and in the output.

This constraint should be ranked lower than the markedness constraint, since the vowel has to be retroflexed in the data. However, since it contains a single opacity, the Classic OT will have the limit to solve the problem. Instead of applying to the other methods, here I will analyze it step by step with a derivation account.

First of all, the rules are as below,

Feature spreading: V--->Vʳ / \_+əʳ

Retroflex vowel deletion: əʳ----> Ø / \_#

/a/+/əʳ/ -----&gt;[ɑʳ]

Input:/a/+/əʳ/	Vowel[+retro]	IDENT-IO[+retro]
→ [ɑʳəʳ]		*
[ɑəʳ]	*!	

Input:/ɑʳəʳ/	*V-mannerV-manner	MAX-IOV-manner
[ɑʳəʳ]	*!	
→ [ɑʳ]		*

In the first tableau, the first procedure is that the retroflex vowel spreads its retroflex feature to the stem vowel. Then as we can see that the optimal one is the first candidate. Then the retroflex vowel gets deletion, thus in the second tableau, the second candidate is the optimal one. Then given the data as below,

/əj/+/əʳ/ -----> [əʳ]  
 /ən/+/əʳ/ -----> [əʳ]  
 /əw/+/əʳ/ -----> [əʳ]  
 /an/+/əʳ/ -----> [ɑʳ]  
 /aw/+/əʳ/ -----> [ɑʳ]

I will take one example,

/an/+/əʳ/ -----&gt; [ɑʳ]

Input:/an/+/əʳ/	Vowel[+retro]	IDENT-IO[+retro]
→ [ɑʳnəʳ]		*
[ɑnəʳ]	*!	

Input:/ɑʳnəʳ/	*V-mannerC-mannerV-manner	MAX-IOC-manner
→ [ɑʳəʳ]		*
[ɑʳnəʳ]	*!	

Input:/ɑʳəʳ/	*V-mannerV-manner	MAX-IOV-manner
[ɑʳəʳ]		*
→ [ɑʳ]	*!	

Here the procedure contains three steps. The first one is the spreading of the retroflex feature to the stem vowel, then the second step is to eliminate the final consonant to avoid three moras in one syllable. In the last step, the retroflex vowel gets deletion itself. Then we turn to group of data which has a double opacity.

/aŋ/ + /əʳ / -----> /ãʳ/  
 /əŋ/ + /əʳ / -----> /ẽʳ/  
 /uŋ/ + /əʳ / -----> /ũʳ/

The rules are as below,

Nasalization: V---> Ñ/\_ŋ+əʳ  
 Feature spreading: V--->Vʳ / \_+əʳ  
 Retroflex vowel deletion: əʳ----> Ø / \_#

I will take /aŋ/ + /əʳ / -----> /ãʳ/ as the example,

The markedness constraint should be proposed that

V-manner[nasal]ŋ

There must be a nasal feature in V-manner in front of a velar nasal.

This constraint is modified by \*V<sub>oral</sub>ŋ, which requires the vowel in front of a nasal must not be oral. And the faithfulness constraint is IDENT-IO[nasal],

IDENT-IO[nasal]

Segments have identical nasal feature in the input and in the output.

The process is as such,

/aŋ/ + /əʳ / -----> /ãʳ/

Input:/aŋ/ + /əʳ /	V-manner[nasal]ŋ	IDENT-IO[nasal]
→ [ãŋəʳ]		*
[aŋəʳ]	*!	

Input:/ãŋəʳ/	*V-mannerC-mannerV-manner	MAX-IOC-manner
→ [ãəʳ]		*
[ãŋəʳ]	*!	

Input:/ãəʳ/	Vowel[+retro]	IDENT-IO[+retro]
→ [ãʳəʳ]		*
[ãəʳ]	*!	

Input:/ãʳəʳ/	*V-mannerV-manner	MAX-IOV-manner
[ãʳəʳ]		*
→ [ãʳ]	*!	

As we can see from the whole process, the first step is to nasalize the nuclear vowel. Then the second is to delete the final consonant. After that, the retroflex vowel spreads its retroflex feature to the nuclear vowel and the last step is that the retroflex vowel gets deletion of itself. The last example is with /iŋ/ + /ə/ -----> /jə̃/. Here the markedness constraint is modified as such,

V-place[dor]

There must be a dorsal feature in the V-place.

And the faithfulness constraint is DEP-IOV-place[dorsal],

DEP-IOV-place[dor]

The dorsal feature in V-place in the output has a correspondence in the input (no insertion).

The two constraints interact with each other in the tableau to help select the best candidate.

Input:/iŋ/ + /ə/	V-place[dor]	DEP-IOV-place[dor]
[iŋə̃]	*!	
→ [jə̃]		*

Input:/jə̃ə̃/	V-manner[nasal]ŋ	IDENT-IO[nasal]
→ [jə̃ə̃]		*
[[jə̃ə̃]	*!	

Input:/jə̃ə̃/	*V-mannerC-mannerV-manner	MAX-IOC-manner
→ [jə̃ə̃]		*
[jə̃ə̃]	*!	

Input:/jə̃ə̃/	Vowel[+retro]	IDENT-IO[+retro]
→ [jə̃ə̃]		*
[jə̃ə̃]	*!	

Input:/jə̃ə̃/	*V-mannerV-manner	MAX-IOV-manner
→ [jə̃ə̃]		*
[jə̃ə̃]	*!	

In this process, there is an insertion of the retroflex vowel in the syllable in addition. And then the other steps remain the same as in the last example. The vowel gets nasalization from the final velar consonant and then the velar nasal gets itself deleted. Moreover, the retroflex

vowel spreads its retroflex feature to the nuclear vowel and then gets deletion as well. The process involves the assimilation of the nuclear vowel and the velar nasal, also the assimilation of the retroflex vowel and the nuclear vowel. In general, the retroflex suffixation doesn't only involve a requirement of an assimilation of a dorsal feature in vowels, but also a requirement of an assimilation of the nasal feature between the vowels and the velar nasal finals.



## Chapter 5

# General Conclusion

In the paragraphs above, I have analyzed the retroflex suffixation in three different angles according to the underlying form of the retroflex suffix. The retroflex suffixation has been always an hot issue through decades. With the variable analysis, the debate falls into three parts, the underlying form of the vowels, the underlying form of the retroflex suffix and the process of the opacity. The aim of the paper is to discuss about the former studies and create a new idea about the retroflex suffixation, no matter what is the underlying form of the retroflex suffix. To be worthy of noticing, the first priority of this paper is to figure out what are the underlying forms of the vowels. To be distinguished from other analysis about the underlying form of the vowels, I propose a renovation of the diphthongs, which is that there is no diphthongs indeed in Mandarin. This proposal is depending on Duanmu's (1990a) about the underlying form of the diphthongs. And due to the behaviors of the vowels [i], [y], [u], they are more likely to be approximants underlyingly. Hence, the underlying forms of the diphthongs should be postulated as a nuclear vowel plus a pre-nuclear glide or a post-nuclear glide. Within the postulation, the first problem is solved. Then other than defying the definition of what the underlying form of the retroflex vowel, the hypothesis is to assume that the underlying form of the retroflex suffix can be a consonant, a floating feature and also a retroflex vowel with a retroflex feature. The analysis will be divided into three parts according to the different hypothesis about the underlying form of the retroflex suffix. First of all, I take the retroflex vowel as an approximant, then I apply the Parallel Structure of Feature Geometry (Morén, 2003) to analyze the feature of the final consonant and the vowels with a pair of features in manner and place. The Parallel Structure of Feature Geometry (Morén, 2003) is a modified theory of feature geometry and it contains economy and efficiency in analyzing features. With a comparison of two contrast features to indicate the differ of the vowels and the consonants, I list a tableau for the features of all the vowels and consonants and draw a skeleton of the PSM structure for retroflex suffixation. Given the data, I separate them as groups to analyze it step by step. As we can see from the data, the retroflex suffix causes a deletion because there is a consonantal cluster in the final endings. Then according to the structure, the dorsal feature is essential for vowels to be retroflexed. Thus, the high front vowels are not fit in this condition so that they become a pre-nuclear glide. In that case, there will be an insertion of the retroflex vowel in the syllable. And before the final consonants getting deletion of themselves, only the velar nasal spreads its nasal feature to the nuclear vowel. This procedure contains a nasalization of the vowels. Moreover, the whole process is concerning a single opacity. For analyzing this, I first apply to Local conjunction (Smolensky, 1997) to account for this phenomenon. It seems that the velar nasal with dorsal feature is more preferring to preserve nasal feature than the alveolar nasal with coronal feature. So with a PSM feature specification, I assume to bind the dorsal feature and the nasal feature together to analyze it. The local conjunction is appropriate for the binding of two features. It is only violated by violating both constraints. Here It helps to account for the retroflex suffixation when the retroflex suffix is an approximant.

With another hypothesis of the retroflex suffix as a floating feature, there is also a single opacity when the velar nasal spreads its nasal feature to the nuclear vowel. Here instead of applying for local conjunction, I adopt OT-CC (McCarthy, 2006&2007) to account for this phenomenon. Since the Classic OT is not containing an intermediate stage in analyzing the opacity and the Classic OT sometimes chooses the transparent candidate instead of the opaque one, the OT-CC is helpful with an intermediate stage in advance. With a traditional idea of that the candidates are infinite in GEN, the OT-CC candidate chains are advanced in selection of the potential candidate instead of listing the infinitive candidates. The candidate chains makes sure that the candidates are finite to be analyzed. Therefore, in the process, the order of two faithfulness constraints is the key to solve an opacity. The  $PREC(A, B)$  is the key for solving the problem. As to the last hypothesis of the retroflex suffix as a retroflex vowel, I apply the OT-CC as well to solve it out. Since the retroflex suffix is a vowel with a retroflex feature, here it doesn't only contain a single opacity, but also a double opacity. The rules are concerning about the retroflex feature spreading, the retroflex vowel deletion and the nasalization of the nuclear vowel. Thus, with a consideration of four potential competitive candidates, the double opacity will be solved by two  $PREC(A, B)$  constraints. After that, I adjust the PSM structure to analyze it. The retroflex vowel will have a retroflex feature in C-place. And with the consideration of the manner and place constraints, I list the derivation of the retroflex suffixation in tableaux to be clarified. To sum up, the retroflex suffixation contains an assimilation of spreading the retroflex feature in vowels and the nasalization of the nuclear vowels. The process contains the single opacity when the underlying form of the retroflex suffix is a consonant or a floating feature and also double opacity when the underlying form of the retroflex suffix is a retroflex vowel. With analyzing this issue, I hope the idea for retroflex suffixation in Mandarin will be extended to cover other issues in other dialects or other languages.

# Bibliography

- Blevins, J. 1995. The syllable in phonological theory. In Goldsmith John(eds). *The handbook of phonological theory*. Blackwell Publisher:206-244.
- Bye, Patrik A. 2002. *Virtual phonology: Rule Sandwiching and Multiple Opacity in North Sami*. Ph. D. Dissertation. University of Tromsø. [ available on ROA-498].
- Chao, Y.R. 1979. *Hanyu kouyu yufa*(A grammar of spoken Chinese). Beijing: Shangwuyinshu Guan.
- Cheng, Chin-Chuan. 1973. *A synchronic phonology of Mandarin Chinese*. The Hague: Mouton.
- Cheng, R.L. 1966. Mandarin phonological structure. *Journal of Linguistics* 2:135-158.
- Chomsky, Noam&Morris Halle. 1968. *The sound pattern of English*. New York:Harper&Row.
- Clements, G.N. 1985. The geometry of phonological features. *Phonology Yearbook*2.
- Clements, G.N. 1991a. Place of articulation in consonants and vowels: *A unified theory*. In *working papers of the Cornell Phonetics Laboratory, vol.5*. Ithaca: Cornell University.
- Clements, G.N. 1991a. Vowel height assimilation in Bantu languages. In *working papers of the Cornell Phonetics Laboratory, vol.5*. Ithaca: Cornell University.
- Clements, G. N. and E. V. Hume. 1995. The Internal Organization of Speech Sounds. In John A. Goldsmith (ed.). *The Handbook of Phonological Theory* (pp. 245-306). Cambridge: Blackwell.
- Cohn, A.1990. Phonetic and phonological rules of nasalization. *UCLA working papers in phonetics* 76. Department of Linguistics, UCLA.
- Duanmu, San. 1990a. *A formal study of syllables, tones, stress and domain in Chinese language*. Ph.D. Disertation. MIT.
- Emeneau, Murray B. 1939. The vowels of the Badaga Language. *Language* 15:4-43.
- Fu, Y.-C. 1980. The /-r/ suffixation and phonological structure of Mandarin finals. Wenshin Publishing Co. Taipei.
- Flemming, E. 1995. Auditory representation in phonology. Ph.D. Dissertation. *UCLA*. Published in 2002 by Routledge.

- Goldsmith, John. 1976. *Autosegmental phonology*. Ph.D. Dissertation. MIT.
- Kager, René. 1999. *Optimality Theory*. Cambridge University Press.
- Kenstowicz, M&C. Kisseberth. 1977. *Topics in phonological theory*. New York: Academic Press.
- Kiparsky, P. 1982. From cyclic phonology to lexical phonology. In H.van der Hulst and N.Smith(eds.). *The structure of phonological representations, voll.* Dordrecht:Foris.
- Lin, Yen-Hwei. 1989. *Autosegmental treatment of segmental process in Chinese phonology*. Ph. D. dissertation. The University of Texas at Austin.
- Ma, Lili. 1997. Mandarin diminutive formation: An optimality Analysis. *Working papers of the linguistics circle in Victoria*. vol 14:47-60.
- Ma, Qiuwu. 2001. Mandarin retroflex suffixation: an OT account. Beijing Normal University. Available on ROA-454.
- McCarthy, J. 1988. Feature geometry and dependency: A review. *Phonetics* 43:84-108.
- McCarthy, J.&A. Prince. 1993a. *Prosodic morphology I: Constraint interaction and satisfaction*. University of Massachusetts. Amherst and Rutgers University.
- McCarthy, J.&A. Prince. 1995. Faithfulness and reduplicative identity. *Papers in Optimality Theory*. Amherst: GLSA: 249-384.
- McCarthy, J. 1999. Sympathy and Phonological Opacity. *Phonology* 16:331-399.
- McCarthy, J. 2006. Candidates and Derivations in Optimality theory. University of Massachusetts, Amherst.
- McCarthy, J. 2007. Hidden Generalization-Phonological Opacity in Optimality Theory. Equinox Publishing Ltd, London.
- Morén, B. 2003a. The Parallel Structures Model of Feature Geometry. In *Working Papers of the Cornell Phonetics Laboratory*, vol. 15. Ithaca: Cornell University.
- Morén, B. 2003b. Featural and Representational Economy: The Parallel Structures Model of Feature Geometry. Presented at the Center for Advanced Study in Theoretical Linguistics (CASTL) Kick-off Conference. Tromsø, Norway.
- Morén, B. 2003c. The Parallel Structures Model of Feature Geometry: Some Manner/Major Class Feature Acquisition Predictions. Presented at the Center for Advanced Study in Theoretical Linguistics (CASTL) Language Acquisition Workshop. Tromsø, Norway.

- Morén, Bruce. 2007. The Division of Labor between Segment-internal Structure and Violable Constraints. In M. Krämer, P. Bye, and S. Blaho, eds., 'Freedom of Analysis?'
- Morén, Bruce. 2007. Minimalist/Substance-free Feature Theory: Case Studies and Implications. 1-week course at the Eastern European Generative Grammar summer school (EGG). Brno, the Czech Republic.
- Piggott, G. 1988. *The parameters of nasalization*. McGill University.
- Prince, Alan&Paul Smolensky. 1993. *Optimality Theory: Constraint Interaction in Generative Ms.*,Rutgers University and University of Colorado.
- Rubach, J&G.E. Booij. 1990. Syllable structure assignment in Polish. *Phonology*7:121-158.
- Sagey, E.1986. *The representation of features and relation in Nonlinear phonology*. Ph.D Dissertation. MIT.
- Steriade, D. 1993a. Closure release and nasal contours. In *M.Huffman and R.Krakow (eds.), Nasals, Nasalization and the Velum*. Academic Press, pp. 401-470
- Smolensky, P. 1997. Constraint interaction in generative grammar II: Local conjunction or random rules in Universal Grammar. *Paper presented at the Hopkins Optimality Theory Workshop/Maryland Mayfest '97*. Baltimore, Maryland.
- Wang, F.S. 1963. Beijinghua yunmu de jige wenti( A few problems on syllable finals in Beijing Dialect). *Zhongguo Yuwen* 2:115-124.
- Wang, L.J.1991. *Yinxixue jichu* (Phonological preliminaries). Beijing: Yuwen Chuban She.
- Wang, L.J.&N.J.He. 1985. Beijing Erhuayun de tingbaian shiyan he shengxue fenxi(Auditory discrimination experiments and acoustic analysis of Mandarin retroflex). *Beijing yuyin shiyan lu*. Beijing: Beijing University Press:27-72.
- Wang, Z.J. 1993. *The geometry of segmental features in Beijing Mandarin*. Ph.D. Dissertation. The University of Delaware Newmark.
- Wang, Z.J. 1997. “Erhuayin de tezhen jiagou”(Feature geometry of the retroflexed rhymes). *Zhongguo Yuwen*1:2-10.
- Yin, Yunmei. 1989. *Phonological aspects of word formation in Mandarin Chinese*. Ph.D. Dissertation. The University of Texas at Austin.
- Youssef, I. 2010. Laryngeal assimilation in Buchan Scots. *English Language and Linguistics* 14.3: 321–345. Cambridge University Press.

Zhu, D.X.1980. *Xiandai hanyu yufa yanjiu*(Research on modern Chinese grammar). Beijing: Shangwu Yinshu Guan.

Zhang, L. 2000. A phonetically-based OT account for the /n/-/ŋ/ asymmetry upon /r/-suffixation in Northern Chinese Dialects. *CSLI*. University of California.