

Multi-fluidic Simulation using Multiphysics tools: Case Study on a LNG Plant



H. Khawaja, T. Schive, K. Edvardsen
 Department of Engineering and Safety,
 The Arctic University of Norway, Tromsø, Norway

Abstract

The work focuses on “multi-fluidic simulation of an LNG Plant”. A pipeline quality LNG (Liquefied Natural Gas) contains minimum of 75 % methane (CH₄) with some heavier hydrocarbons and carbon dioxide. Natural gas of suitable quality is liquefied in order to reduce its volume and make it commercially viable for transport via sea vessels, transport vehicles, etc. In an LNG plant, gas undergoes various process steps before it is liquefied. The process steps required include: field operations, inlet compression, gas treatment, dehydration, hydrocarbon recovery, nitrogen rejection, liquefaction, storage and transportation. Field operations may include upstream analysis, free liquid separation, dehydration, acid gas removal and compression. Inlet compression is performed to ensure the needed pressure for further operations. The gas treatment process removes CO₂ and H₂S contents from the gas. It is essential to remove these components to reduce the possibility of corrosion in the pipes and process plant equipment. Gas dehydration is performed to remove water from the gas. Heavier hydrocarbon are separated from the gas in the hydrocarbon recovery operation. Nitrogen rejection process is used to separate nitrogen from the gas. Liquefaction is performed on the gas by cooling and compressing the gas in multi stage processes. Liquefied gas is stored at low pressures and temperatures. Possible cooling needed to maintain such conditions is achieved through the condensation of boil-off gas, which is re-circulated in the liquefaction process. In this work, HYSYS® (a software based on equation of state, laws of conservation of mass and energy) is employed to simulate above given processes. The achieved results are discussed and conclusions are drawn.

LNG Processing

Overview of LNG Processing

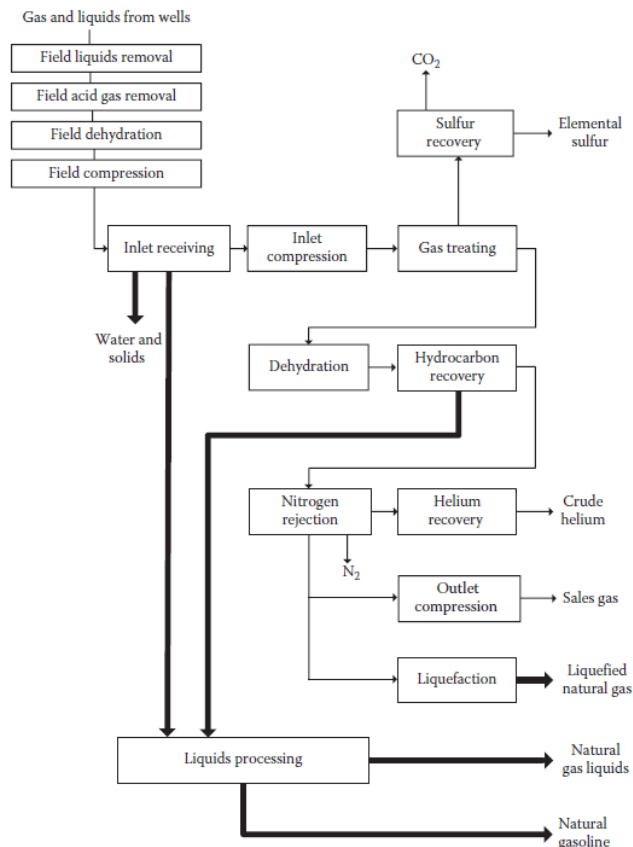

LNG Process Simulation (HYSYS®)

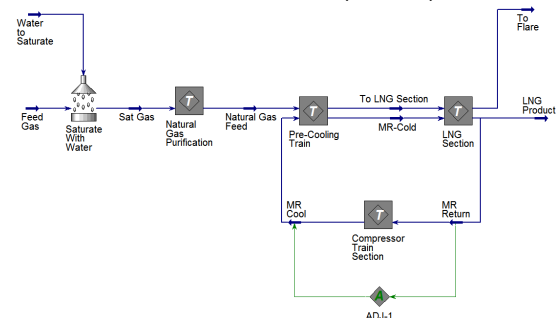

LNG Processing Plant (Melkøya, Norway)



LNG Transportation



Conclusion

Gas obtained from the wellhead goes through various processes such as gas treatment, dehydration, hydrocarbon recovery, nitrogen rejection, liquefaction before it is transported in form of LNG. These processes can be simulated in HYSYS® using multi-fluidic simulations.

Limitations

HYSYS® simulations are limited by the solution of equation of states (EOSs) and laws of conservation of energy & mass. Fluid problems require law of conservation of momentum can not be solved in HYSYS®.

Contact

H. Khawaja

Assoc. Professor,
 University of Tromsø,
 Tromsø, Norway

E-mail:
 hassan.a.khawaja@uit.no