

Faculty of Health Sciences.

# ***Clonal Diversity and multiresistance in Quinolone Resistant Escherichia coli.***

---

**Linda Strand**

*A dissertation for the degree of Philosophiae Doctor – october 2014*

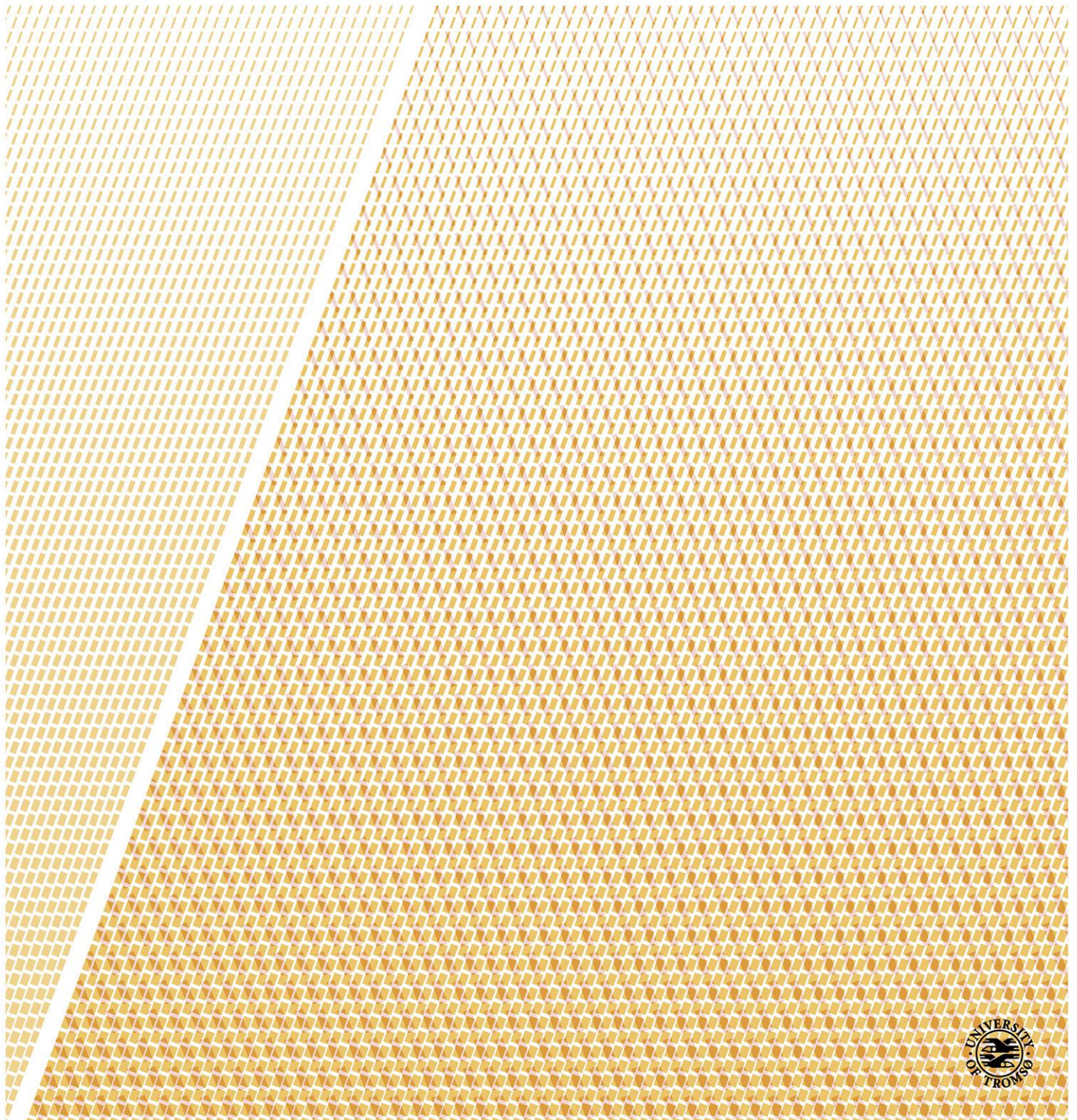



Clonal diversity and multiresistance in quinolone resistant *Escherichia coli*

**Linda Strand**

**University of Tromsø**

**2015**



Education is only a ladder to gather fruit from the tree of knowledge, not the fruit itself.

*Albert Einstein*

## Contents

1	Acknowledgements .....	5
2	Abberations .....	6
3	Introduction .....	7
3.1	<i>Escherichia coli</i> .....	9
3.1.1	Habitats of <i>E. coli</i> .....	9
3.1.2	Population structure .....	9
3.1.3	Uropathogenic clonal groups .....	11
3.2	Typing methods .....	12
3.2.1	Serotyping .....	13
3.2.2	Multilocus enzyme electrophoresis (MLEE) .....	13
3.2.3	Ribotyping .....	13
3.2.4	MLST (multilocus sequence typing) .....	13
3.2.5	Phylogenetic grouping by triplex PCR .....	14
3.2.6	PFGE (Pulse Field Gel electrophoresis) .....	14
3.2.7	Amplified Fragment Length Polymorphism (AFLP) .....	15
3.2.8	Antibiotic resistance pattern .....	15
3.3	Mobile Genetic elements .....	15
3.3.1	Plasmids .....	15
3.3.2	Transduction via bacteriophage .....	16
3.3.3	Transposons .....	16
3.3.4	Integron .....	17
3.3.5	Insertion Sequence Common Region Element (ISCR) .....	17
3.3.6	Genomic Islands .....	17
3.4	Antimicrobials: antibiotics, chemotherapeutic agents and drug resistance .....	18
3.5	Multiresistance .....	20
3.6	Quinolones; mechanism of action .....	20
3.7	Quinolone resistance mechanisms .....	21
3.7.1	TARGET-ENZYME RESISTANCE .....	21
3.7.2	INFLUX-EFFLUX RESISTANCE .....	22
3.7.3	PLASMID-MEDIATED RESISTANCE .....	22
3.7.4	Mutation rate and MPC .....	23
3.8	Multiresistant Fluoroquinolone resistant <i>E. coli</i> .....	23
3.8.1	SOS-driven evolution to antibiotic resistance .....	23

3.9	Virulence and virulence factors.....	24
4	The study.....	25
4.1	Aims.....	25
4.2	Hypothesis.....	25
4.3	List of papers.....	26
4.4	Summary of material and methods.....	27
4.5	The main results.....	29
4.6	<b>Discussion and conclusion.....</b>	<b>32</b>
4.7	<b>Main conclusions/further work.....</b>	<b>42</b>

## 1 Acknowledgements

The planning of this study and the laboratory work was done at A/S Telelab microbiological laboratory (later Unilabs Telelab as) in Skien. This work has been a part of Telelab's internally funded research program in addition to grants from the Scandinavian Society for Antimicrobial Chemotherapy and Norsk Overvåkingssystem for antibiotikaresistente mikrober (NORM) and tax relief via the Skattefunn system. The articles included in this study and this thesis was written at the section of medical genetics, Telemark Hospital.

I would like to express my sincere gratitude to everyone who helped me during my work with this thesis.

First and foremost I thank my principal supervisor professor Andrew Jenkins, my earlier superior at A/S Telelab and now professor at Telemark University College. You have encouraged me to keep on during all this years by hundreds of interesting discussions; from planning during the laboratory work to analysing, writing articles and thesis. Without your support I would not have been able to deliver this thesis.

I also thank my co-supervisors; Prof. dr. med Bjørn-Erik Kristiansen for being positive and supporting the study, dr. med Nils Grude for including me in his study and letting me take over after his thesis and Prof. dr. med Arnfinn Sundsfjord for constructive input during project planning and writing the thesis.

To all my supervisors: Your experience in the field has given me this opportunity.

A special thanks to the master students Nina Narmoe Egeberg, Beathe Kiland Langerud, Hilde Mykland and Ingrid H Henriksen for doing such a great job in the laboratory.

I am grateful to my colleagues, Anne-Gry Allum and Randi Kersten Aakre, who have provided excellent technical assistance and been an invaluable support for me both at Telelab and later as colleagues at Telemark Hospital.

Thanks to all colleagues at Telelab and Unit for Medical Genetics at Telemark Hospital for making a challenging, positive and cooperative environment. A special thanks to my superior Camilla Furu Skjelbred for facilitating my work at Telemark Hospital in a way that made it possible for me to complete my articles and thesis.

My greatest gratitude goes to my family for their love and support; my husband Knut Olav and our daughters Therese and Anette, my parents Arne and Sissel, my parents-in-law Agnar and Ragnhild and my brother Lasse with his family.

Porsgrunn, September 30<sup>th</sup>, 2014

Linda Strand

## 2 Abberations

AFLP	Amplified fragment length polymorphism
CgA	Clonal group A
DAEC	Diffusely adherent <i>E. coli</i>
<i>E. coli</i>	Escherichia coli
EAEC	Enteraggregative <i>E. coli</i>
ECOR	<i>E. coli</i> reference collection
EHEC	Enterohemorrhagic <i>E. coli</i>
EIEC	Enteroinvasive <i>E. coli</i>
EPEC	Enteropathogenic <i>E. coli</i>
ETEC	Enterotoxigenic <i>E. coli</i>
EUCAST	European committee on antimicrobial susceptibility testing
ExPEC	Extraintestinal <i>E. coli</i>
HGT	Horizontal gene transference
IR	Inverted repeats
IS	Insertion sequence
ISCR	Insertion sequence common region element
ISCR	Insertion sequence common region element
MIC	Minimum inhibitory concentration
MLEE	Multi locus enzyme electrophoresis
MLST	Multi locus sequence typing
MPC	Minimal prevention concentration
NMEC	Neonatal meningitis <i>E. coli</i>
PAI	Pathogenicity island
PCR	Polymerase chain reaction
PFGE	Pulsed field gel electrophoresis
PMQR	Plasmid mediated quinolone resistance genes
QRDR	Quinolone resistance determining region
R-plasmid	Plasmids carrying antibiotic resistance genes
SNP	Single-nucleotide polymorphism
ST	Sequence type
UPEC	Uropathogenic <i>E. coli</i>
UTI	Urinary tract infection
WGS	Whole genome sequencing



### 3 Introduction

Quinolones are synthetic bactericidal agents that bind DNA gyrase and topoisomerase IV and inhibit DNA replication[1]. The first quinolone, nalidixic acid, was introduced for treatment of uncomplicated urinary tract infections caused by enteric bacteria in the 1960s but resistance soon developed in a number of organisms. Fluoroquinolones were introduced in the 1970-1980s. These antibiotics differed from the first quinolones by exhibiting a broader spectrum of antibacterial activity and decreased selection of resistant bacteria. Resistance to first generation quinolones may be introduced by one chromosomal mutation in DNA gyrase or topoisomerase IV altering the drug target while clinical resistance to fluoroquinolones needs two or more mutations [2]. Other resistance mechanisms like altered permeability to the agents and enzymatic modifications are also described [3, 4].

Since the broad spectrum fluoroquinolone antibiotics were introduced in clinical practice, resistant *Escherichia coli* (*E. coli*) strains have been isolated with increasing frequency. In Norway, fluoroquinolone resistance in *E. coli* remains an emerging phenomenon, having increased from 1.9% in 2003 to 11,7% in 2012, while in many other European countries, such as Spain, it is now endemic, having increased from 21% in 2001 to 34.5% in 2011[5].

Urinary tract infections (UTI) are one of the most common bacterial infections in humans [6]. Symptomatic UTI is very common in women and 11 % of sexually active women aged 18 and older reported at least one presumed UTI during the last 12 months. The majority of cases occurred among women with recurrent UTI [7]. It has been estimated that 40-50 % of women will experience at least one episode of UTI during their lifetime [8-10]. Uncomplicated UTI is known as simple cystitis in an otherwise healthy patient where only the bladder is infected and pyelonephritis where the kidneys are infected. Most urinary tract infections (80-90%) are caused by *E. coli*.

Bacterial resistance to more conventional UTI therapeutics is increasing in Norway [11], and the use of fluoroquinolones to treat UTI may be expected to increase. Monitoring quinolone-resistance is given high priority by the NORM surveillance programme for antimicrobial resistance in human pathogens and the Norwegian Reference Group on Antibiotic Susceptibility Testing (AFA) [12].

Fluoroquinolone resistance among *E. coli* isolates is presumed to arise by selection of drug resistance in the resident intestinal flora during fluoroquinolone therapy. This provides a reservoir of fluoroquinolone resistant strains that may contribute to future infections [13].

Johnson suggested that the use of antimicrobial agents in food animals may make a greater contribution to such resistance than has previous been suggested [14].

In Norway the use of quinolones in veterinary medicine is limited but there is still some use in fish farms where the total use of antimicrobial agents was reported to be 1.591 kg in 2012 of which quinolones accounted for 88% [15]. In contrast to many other countries Norway does not use quinolones in the poultry production [16].

Quinolone resistance is principally due to chromosomal mutations. In gram negative bacteria mutations in the gene for DNA gyrase (*gyrA*) prevent binding of quinolone to the target enzyme, while other mutations affect intracellular quinolone concentrations by up-regulating transmembrane efflux pumps (for example *marOR/acrR* mutations, affecting the efflux pump AcrAB-TolC) or reducing uptake (for example *ompF* mutations) [17, 18]. While only a single *gyrA* mutation is required for high level nalidixic acid resistance, two mutations in *gyrA* are required for clinical levels of fluoroquinolone resistance. Resistance mutations accumulate in a stepwise fashion. Recent studies indicate that quinolone resistant *E. coli* isolates are hypermutable, and mutators can drive the evolution of fluoroquinolone resistant *E. coli* [2, 19].

Marcusson et al examined drug-susceptibility and fitness in isogenic strains carrying combinations of five commonly occurring mutations known to cause fluoroquinolone resistance including efflux mutations. They found that efflux mutations significantly decreased bacterial fitness while some additional mutations increased fitness. Their data suggests that natural selection for improved growth in bacteria with low- level resistance to fluoroquinolones could in some cases select for further increase in resistance. Thus increased resistance to fluoroquinolones could be selected even in the absence of further exposure to drug [20].

Quinolones induce the SOS-response, which generates changes that decrease porin-mediated influx and increase efflux [21-23]. The SOS response also leads to increased recombination and mutagenesis. It has been reported that the antibiotic induced SOS-response promotes the transposition activity of pathogenicity islands (not uncommonly leading to their loss) and the mobilization of integrating conjugative elements and plasmids[2, 19]. Thus, it seems possible

that quinolones may facilitate the development of quinolone resistance by stimulating mutagenesis and the mobilisation of other resistance determinants.

Low-level quinolone resistance may be mediated by transmissible factors. Plasmid mediated quinolone resistance elements encoding a protein protecting DNA gyrase from quinolone inhibition were first described by Luis Martinez-Martinez *et al.* in the late 1990s [24]. Several other transferable quinolone resistance elements were discovered while the present project was ongoing [3].

### **3.1 *Escherichia coli***

*Escherichia coli* belong to the Enterobacteriaceae family which belong to Gammaproteobacteria in the kingdom Eubacteria. *E. coli* is gram-negative, facultatively anaerobic and non-sporulating. The cells are rod-shaped and measure about 2 µm in length and up to 1 µm in diameter. *E. coli* exhibits a very high degree of phenotypic and genotypic diversity and their core genome represent averagely 2/5 of the total genome [25].

#### **3.1.1 Habitats of *E. coli***

The primary habitat of *Escherichia coli* is the lower intestinal tract of warm-blooded animals. The secondary habitat is soil and water where its half-life is just a few days [26]. *E. coli* is one of the most studied bacteria in the intestinal microflora although the facultative anaerobic bacteria such as *E. coli* and *enterococci* constitute only 0.1-1% of the intestinal bacterial population [27].

The normal intestinal microflora is a complex ecosystem arising after birth when exposed to maternal faecal flora [28] and flora from other individuals in their environment [29].

*E. coli* strains in the intestinal flora can be divided into resident strains which stay in the flora for an extended time and transient strains unable to colonize long term [30-32].

#### **3.1.2 Population structure**

The population structure of bacteria is more or less defined by the balance between recombination and mutation, shifting from a clonal structure when recombination is low and there is very strong linkage between alleles to a non-clonal structure when recombination is high with weaker linkage between alleles [33].

The population structure of *E. coli* is predominantly clonal [33] built up of a core genome of only about 2000 conserved genes shared by all strains. The rest of the genome represents accessory genes and the average *E. coli* genome contains a total of 4721 genes [25].

Multi locus enzyme electrophoresis (MLEE) using 38 enzymes identified four main phylogenetic groups (A, B1, B2 and D) [34, 35] and two accessory groups (C and E) [36, 37]. Multi locus sequencing technology (MLST) analysis based on 8 housekeeping genes (4095 nucleotides in total) recovered these groups with exception of group C. Sequencing 1878 genes of the *Escherichia* spp. core genome and the 2.6 million nucleotides of the chromosomal backbone recovered the five groups from MLST. The use of *Escherichia fergusonii*, the closest relative of *E. coli*, as the out-group allowed a robust phylogeny to be built; the first split in *E. coli* phylogenetic history leads to one branch containing B2 and a subgroup of D with another branch containing the remaining strains. The remaining strains of group D emerged from the second branch, followed by group E and at last A and B1 groups appear as sister groups (figure 1) [25, 38, 39]. The high genetic diversity among the B2 group indicates its early emergence and suggests that it has subspecies status [40].

Certain specific genes are found to be characteristic for the phylogroups and form the basis of PCR-based characterisation of phylogroup A, B1, B2 and D [41], see chapter 1.2.4.

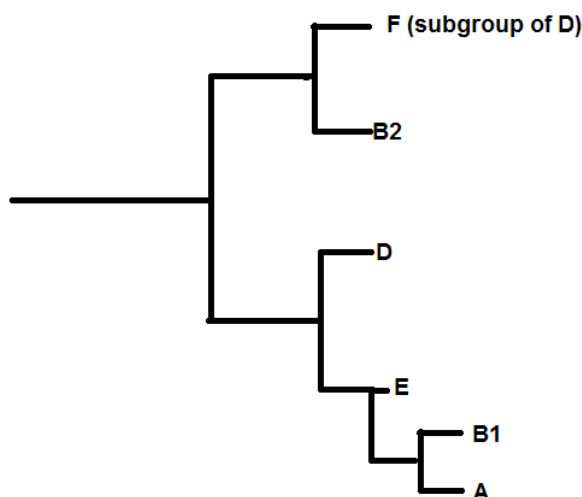

Figure 1: *E. coli* phylogeny based on sequences of 8 housekeeping genes (4095 nucleotides in total) in 72 strains from the *E. coli* reference collection (ECOR) rooted on *Escherichia fergusonii*.

### 3.1.3 Uropathogenic clonal groups

While phylogroup defines the ancestral relationship of the bacteria, typing of pathogenic bacteria often address the investigation of a local outbreak or a more long term or global epidemiology of pathogenic bacteria. Different types of molecular methods and methods to investigate epidemiology and phylogeny of *E. coli* are described in chapter 3.2.

Below the level of phylogenetic group a number of global and local “clonal groups” are recognized.

Two fluoroquinolone-resistant clonal groups, O15:K52:H1 (phylogenetic group D) and O25:H4 (ST131, phylogenetic group B2) in Europe have been reported to account for approximately one third of fluoroquinolone resistant uropathogenic *E. coli* [42]. A related clonal group, Clonal group A (CgA) (Phylogenetic group D) is uropathogenic and globally distributed [43, 44]. The methodological basis for defining these clonal groups varies.

O15:K52:H1 and CgA have been screened for by SNP-PCR while ST131 is defined by multi locus sequence typing.

#### **O15:K52:H1**

Although urinary tract infection was not usually thought of as a disease associated with community wide outbreaks, *E. coli* O15:K52:H1 caused an outbreak of community-acquired cystitis, pyelonephritis, and septicaemia in South London in 1987 and 1988 [45]. Later this uropathogenic multidrug-resistant clone was shown to be endemic and cause urinary tract infections worldwide [46]. O15:K52:H1 belongs to phylogenetic group D and clonal complex ST31 [47, 48].

#### **Clonal group A (CgA)**

CgA was first recognized in the 1990s and accounted for up to 50% of trimethoprim-sulfamethoxazole resistant UTI *Escherichia coli* in U.S. women with acute uncomplicated cystitis and pyelonephritis [45, 49, 50]. The clonal group exhibited a stereotypical virulence factor profile and a conserved multidrug antimicrobial resistance phenotype, i.e., to ampicillin, chloramphenicol, streptomycin, sulphonamides, tetracycline, and trimethoprim (ACSSuTTp), which was conjugally transferable on a large plasmid [45, 49]. This clonal group is globally distributed and belong to phylogenetic group D and clonal complex ST69 [43, 51-53].

## **ST131**

A single *E. coli* clonal group, ST131 (O25:H24) (phylogenetic group B2) disseminated rapidly among humans all over the world in the 2000s. This clone accounts for a large proportion of the antimicrobial resistance in *E. coli* and is known to exhibit extended-spectrum cephalosporin (ESC) resistance through the production of CTX-M-15, an extended-spectrum beta-lactamase [47, 54-57].

### **3.2 Typing methods**

*E. coli* was first typed based on the elements that can elicit an immune response in the host; the O-H-K-antigen system [58, 59]. This typing has since been supplemented or in part replaced by genetic methods.

Genetic typing methods may be classified according to whether they address the core genome or the entire genome and according to the resolution. Methods that address the core genome are likely to be more phylogenetically valid while methods addressing the entire genome have a greater resolution at strain level and therefore may be more epidemiologically informative.

Techniques used to study *E. coli* population genetics at core genome level include multi locus enzyme electrophoresis (MLEE), multi locus sequencing typing (MLST), ribotyping, and phylogenetic grouping by triplex-PCR.

Methods investigating genetic differences spanning the whole genome include Pulse field gel electrophoresis (PFGE) and Amplified Fragment Length Polymorphism (AFLP). Clonal analysis by PFGE and AFLP are therefore methods frequently used for outbreak investigation where there is interest in a high sensitivity to changes in the whole genome.

In the last decade methods to investigate the entire genome at a higher level of sensitivity have evolved. Microarray and next generation whole genome sequencing (WGS) techniques are now used to investigate the entire genome either by genome study or expression studies. These techniques are expected to give us a lot of new information about the population structure and epidemiology of the bacteria and WGS has already been used for characterisation of bacterial isolates in several large outbreaks, among others the large outbreaks of the German enteroaggregative *E. coli* outbreak strain [60].

### 3.2.1 Serotyping

Serotyping was developed in the 1940s by Kauffman [58] and Orskov [59]. Serotyping is based on the combinations of 173 O antigens, 80 K antigens and 56 H antigens and an extremely high number of serotypes have been described [61]. The O antigens are the repeating oligosaccharides of the lipopolysaccharides (LPS) on the outer membrane of the *E. coli* cell. The O antigen is encoded by the *rfb* gene cluster. The K antigens are acidic capsular polysaccharide (CPS) surrounding the bacterial cell in a thick, mucous-like, layer. The H antigens are the flagella on the outside of membrane and capsule allowing the cells to move [62].

Molecular alternatives based on PCR have now been developed, especially for the typing of O antigens [63].

### 3.2.2 Multilocus enzyme electrophoresis (MLEE)

In the 1980s multilocus enzyme electrophoresis (MLEE) for studying bacteria was developed. MLEE is the characterization of several water-soluble housekeeping cellular enzymes by their relative electrophoretic mobilities. Mobility variants of an enzyme can be equated with alleles at the corresponding locus [35] although a single electrophoretic allele may encompass many sequence variations at the DNA level. The combination of alleles at the various loci defines an electrophoretic type, and the relatedness of isolates can be visualized on a dendrogram produced from a matrix of pairwise comparisons between the electrophoretic types [39]. Analysis of MLEE data can also be used to assess the relative importance of recombination and mutation in bacterial evolution [33].

### 3.2.3 Ribotyping

Ribotyping identifies bacterial isolates by polymorphisms in the chromosomal regions of rRNA operons. Principally the whole chromosome is digested by restriction enzymes, fragments are separated by gel electrophoresis, blotted onto a membrane, denatured and hybridized with probes complimentary to rRNA operon (16S and 23S rRNA) [64-66].

### 3.2.4 MLST (multilocus sequence typing)

MLST is analogous to MLEE with DNA sequence alleles replacing electrophoretic alleles. In the late 1990s, multilocus sequence typing (MLST) emerged as a powerful tool for bacterial population genetics where the nucleotide sequence of several housekeeping genes was determined for each isolate. MLST distinguishes more alleles per locus than MLEE and gives

unambiguous results, thus allowing high levels of discrimination between isolates by using half of the loci that are typically required for MLEE. MLST results are directly comparable between laboratories without the need for normalization [67, 68].

### 3.2.5 Phylogenetic grouping by triplex PCR

Phylogrouping by triplex PCR allows strains to be assigned to one of the four main phylogenetic groups (A, B1, B2 and D) [41]. This is a simple and rapid method widely used since its introduction in 2000. The method uses a combination of three genes: *chuA*, an outer-membrane hemin receptor gene; *yjaA*, which encodes an uncharacterized protein; and a putative lipase esterase gene, *TspE4.C2*. The use of these three markers as a method to assign the strains to their correct MLST-based phylogroup is good with an accuracy of 80-85% [69]. Table 1 shows the decision matrix to determine the phylogenetic groups.

	<i>chuA</i>	<i>yjaA</i>	<i>TspE4.C2</i>
Phylogroup A	-	-/+	-
Phylogroup B1	-	-/+	+
Phylogroup B2	+	+	-/+
Phylogroup D	+	-	-/+

Table 1: Decision matrix to determine phylogenetic groups by triplex PCR [41].

### 3.2.6 PFGE (Pulse Field Gel electrophoresis)

PFGE is restriction analysis of the entire genome using restriction enzymes that cut rarely and generate very large fragments. To keep the genomic DNA from sheering, the bacteria are moulded in agarose gel before lysis and restriction digestion. Slices of agarosegel containing the chromosomal DNA fragments are inserted into the wells of an agarose gel and fragments are resolved into a pattern of discrete bands in the gel by an apparatus that switches the direction of the current. Separation is based on the time DNA fragments of different size take to reorientate themselves in an alternating electric field [70-72]. The DNA restriction patterns of the isolates are then compared with one another to determine their relatedness. PFGE is expected to be sensitive to large scale changes in chromosome structure and the loss or gain of genomic elements that would not be detectable by methods such as MLST. Tenover presented rules for interpretation of PFGE-patterns in outbreak investigations in 1995 [73].



### **3.2.7 Amplified Fragment Length Polymorphism (AFLP)**

Amplified Fragment Length Polymorphism (AFLP) is another method where bacteria are differentiated by cutting genomic DNA using restriction enzymes followed by ligation of oligonucleotide adapters and amplification of fragments using the adapter and restriction site sequence as target site for primers. The fragments are separated in polyacrylamide gels and the resulting band patterns are compared [74].

### **3.2.8 Antibiotic resistance pattern**

Antibiotic resistance pattern in *E. coli* is often used to describe different outbreak strains. Horizontal transfer of antibiotic resistance genes and resistance mutations may rapidly change these patterns. Antibiotic resistance in *E. coli* is described in chapter 3.4. Antibiotic resistance patterns are clinically relevant but phylogenetic uninformative.

## **3.3 Mobile Genetic elements**

Although sexual reproduction does not occur in bacteria, genetic exchange between cells does occur. This is referred to as horizontal gene transfer (HGT). Horizontal gene transfer is a highly significant phenomenon and among single-celled organisms perhaps the dominant form of genetic transfer [75, 76]. HGT is the primary reason for the spread of antibiotic resistance in bacteria and transmission of virulence.

Horizontal gene transfer happens through transformation, transduction and conjugation.

Transformation is the genetic alteration of a cell resulting from active uptake and incorporation of exogenous DNA from its surroundings through the cell membrane [77]. This process does not occur naturally in *E. coli*. Conjugation is the transfer of genetic material between bacterial cells by direct cell-to-cell contact via a bridge-like connection between two cells [78, 79]. Transduction is transfer of bacterial DNA from one bacterium to another by a virus [80]. Conjugation and transduction occur in *E. coli*.

### **3.3.1 Plasmids**

Plasmids are major agents of horizontal gene transfer. They are very frequent, diverse and widespread in all species of bacteria. Plasmids are (usually) circular genetic elements able to replicate independently of the chromosome. Plasmids vary in size from 1 to over 1000 kilobase-pairs and in copy number from one to several hundred per cell [81]. When two plasmids are able to replicate together in one cell, they are compatible. Plasmids which belong to the same compatibility group cannot replicate together in the same cell [82].

Plasmids may also be classified by their ability to transfer to other bacteria. Conjugative plasmids harbour genes encoding proteins involved in DNA transfer and others that function in mating pair formation (*tra region*). Some conjugative plasmids can integrate into the chromosome and mobilize the transfer of chromosomal DNA from one cell to another [81]. Mobilizable plasmids lack genes to initiate transfer but these plasmids may be transferred with conjugative plasmid present in the same cell [83].

An enormous range of genetic functions including nutritional factors, heavy metal resistance, virulence factors and antibiotic resistance is carried on plasmids. Plasmids carrying antibiotic resistance genes are known as R-plasmids. Plasmids may acquire new genetic elements through the action of transposons, insertion sequences, integrons and insertion sequence common region elements [81].

### 3.3.2 Transduction via bacteriophage

Bacteriophages are viruses that infect bacteria and use the replication, transcription and translation machinery of the bacteria to produce new viruses (lytic cycle). The virus may also integrate into the chromosomal DNA of the host or form plasmids in the host (lysogenic cycle). Bacteriophages capable of both cycles are called temperate phages. Generalized transduction is the process when bacterial DNA is packed in some of the virus particles and transferred to a new bacteria while specialised transduction is when temperate virus excise imprecisely from the bacterial genome and bring some of the adjacent bacterial genes into the virus particles. Generalized transduction allows low frequency transfer of all chromosomal genes while specialized transduction can be extremely effective for a very small number of genes [81].

### 3.3.3 Transposons

Transposons, also known as "jumping genes," are DNA sequences that actively move from one location in the genome to another and may include accessory genes coding for antibiotic resistance, pathogenic factors or other traits. Transposition is a rare event occurring  $10^{-5}$ - $10^{-7}$  times per generation [81].

Transposons without additional genes are known as insertion sequences (IS). Insertion sequences (~1000 base pairs) code for transposases which catalyses the enzymatic reaction allowing the IS to move and regulatory proteins which either stimulate or inhibit the transposition activity. The coding region in an insertion sequence is usually flanked by inverted repeats (IR) [81].

Horizontal exchange of transposons may occur either by plasmid-conjugation or transduction. Some transposons are able to mediate their own transfer (Conjugative transposons) [84].

*E. coli* harbour a wide range of transposons conferring resistance to antibiotics and virulence factors [85]. The transposons may harbour integrons capable of picking up new genes [86].

### **3.3.4 Integron**

Integrons are genetic elements that capture genes. They are built up of three components; the gene capture by integrase (*intI*) and recombination site (*attI*) and a gene cassette. The gene cassette was initially discovered in relation to genes coding for antibiotic resistance. Integrons may be found in plasmids, chromosomes and transposons and they are subject to horizontal gene transfer [87].

### **3.3.5 Insertion Sequence Common Region Element (ISCR)**

ISCR elements differ from IS elements by lacking terminal inverted repeats and are thought to be transposed by a mechanism defined as rolling-circle transposition [88]. ISCR elements, as a novel gene capturing system, are capable of mobilizing any piece of adjacent DNA [89]. Nineteen members of the ISCR family have been discovered until now in many Gram-negative pathogens. The majority of these elements are found to be closely associated with antimicrobial resistance genes [90]. ISCR elements are now recognized gene capture and movement systems that also possess the ability to construct extended clusters of antibiotic resistance genes on plasmids as well as on chromosomes [91].

### **3.3.6 Genomic Islands**

Genomic islands are large (10 to 200kb) genomic regions encoding different genes associated with various functions of bacteria. Genomic islands harbouring large clusters of virulence genes are called pathogenicity islands (PAIs). PAIs are associated with transposons, integrons and phage genes participating in horizontal gene transfer of the islands [92, 93].

### 3.4 Antimicrobials: antibiotics, chemotherapeutic agents and drug resistance

Antimicrobials are agents that kill or inhibit the growth of microorganisms. The term antibiotic was first used by Waksman et al in 1942 and defines antibiotics as substances that are produced by microorganisms and are antagonistic to other microorganisms. The definition does not include antimicrobials that are synthetic substances. The term chemotherapeutic agents refers to synthetic antimicrobials [81]. In modern practice it is common to refer to both as antibiotics.

The basic parameter of susceptibility testing is minimum inhibitory concentration (MIC) defined as the lowest concentration of an antimicrobial that will inhibit the visible growth of a microorganism after overnight incubation [94]. Clinical MIC breakpoints are for use in clinical laboratories to advice on patient therapy. European Committee on Antimicrobial Susceptibility Testing (EUCAST) [95] distribute lists breakpoints as sensitive (S), intermediate (I) and resistant (R) and update the lists ones a year. EUCAST do have a procedure for harmonizing and defining breakpoints in Europe.

Antimicrobials mainly target the bacterial cell envelope, DNA replication and protein synthesis, see Table 2.

The first sulphonamide and first commercially available synthetic antimicrobial agent was introduced in 1937 and resistance was reported shortly after. Penicillin (a  $\beta$ -lactam) was introduced as a therapeutic agent several years later. Isolates capable of inactivating the drug had been identified even before the introduction of  $\beta$ -lactams this lead to the production of synthetic variants of the drug resistant to cleavage by  $\beta$ -lactamases. Use of streptomycin (introduced in 1944) was followed by isolation of mutant strains of *Mycobacterium tuberculosis* resistant to therapeutic concentrations in patients after treatment. As other antibiotics have been discovered and introduced into clinical practice, a similar course of events has ensued, see table 2 [81]. The discovery of genetically transferable antibiotic resistance in 1950s was unexpected and introduced the concept of spread of antibiotic resistance genes by bacterial conjugation [96].

Antibiotic class	Introduced to market	Example(s)	Target	Mode(s) of resistance
Penicillins (B-lactam)	1942	(benzylpenicillin)	Peptidoglycan biosynthesis	Hydrolysis, efflux, altered target
amphenicols	1949	Chloramphenicol	Translation	Acetylation, influx/efflux, altered target
Macrolides	1952	Erythromycin	Translation	Hydrolysis, glycosylation, phosphorylation, efflux, altered target
Glycopeptides	1955	Vancomycin	Peptidoglycan biosynthesis	Reprogramming peptidoglycan synthesis
Tetracyclines	1955	Chlortetracycline	Translation	Monoxygenation, efflux, altered target
Cationic peptides	1958	Colistin	Cell membrane	Altered target, efflux
Nitrofurans	~1960	Nitrofurantoin	Inhibition of DNA, RNA, protein and cell wall synthesis	Inhibition of nitrofuran reductase
Pyrimidines	1961	Thrimethoprim	Folat synthesis	Efflux, altered target
Sulfonamides	1961	Sulfamethoxazole	Folat synthesis	Efflux, altered target
Cephalosporins (B-lactam)	1964	(cefalotin)	Peptidoglycan biosynthesis	Hydrolysis, efflux, altered target
Aminoglycosides	1964	Gentamicin, Kanamycin	Translation	Phosphorylation, acetylation, nucleotidylation, efflux, altered target
Rifamycins	1967	Rifampin	Transcription	ADP-ribosylation, efflux, altered target
Quinolones	1967 1987	Nalidixic acid Ciprofloxacin	DNA replication	Acetylation, influx/efflux, altered target
Lincosamides	1968	Clindamycin	Translation	Nucleotidylation, efflux, altered target
Carbapenems (B-lactam)	1985	(imipenem)	Peptidoglycan biosynthesis	Hydrolysis, efflux, altered target
Oxazolidinones	2000	Linezolid	Translation	Efflux, altered target
Monobactams (B-lactam)		(aztreonam)	Peptidoglycan biosynthesis	Hydrolysis, efflux, altered target
Streptogramins		Synercid	Translation	C-O lyase, acetylation, efflux, altered target
Lipopeptides	2003	Daptomycin	Cell membrane	Altered target

Table 2: Discovery, modes of action and resistance mechanisms for the major classes of antibiotics.

Antimicrobial agents for UTI treatment should ideally have primary excretion routes through the urinary tract. Sulphonamides were introduced in the 1940s as the first antimicrobials used in the oral management of acute, uncomplicated UTI. In the 1970s, new therapeutic agents were included: nitrofurantoin, nalidixic acid, cephalexin, trimethoprim-sulfamethoxazole and

amoxicillin. More recently fosfomycin, mecillinam and second generation fluoroquinolones were included to the oral management of UTI.

Resistance towards these antibiotics has emerged to different degrees; Sulphonamide is no longer recommended as single treatment because high level of resistance [97]. Trimethoprim-sulfamethoxazole has been an option for treatment of UTI in 25 years with a significant increase of resistance, mecillinam have been used especially in Nordic countries and there have been little evidence of resistance development while resistance to cephalosporin which not is considered first line therapy for treatment of UTI is increasing. Nitrofurantoin has been an option for treatment of UTI for more than 50 years with a continued low rate of resistance [98]. Aminoglycosides may be used in treatment of *E. coli* and resistance is still low.

Second generation fluoroquinolones have been available in Norway since 1984 and resistance is increasing.

### **3.5 Multiresistance**

Bacteria that are resistant to one member of class of antibiotics are often resistant to other members of the same class. This is referred to as cross resistance. Bacteria may also be resistant to more than one class of antibiotics. This is referred to as multiresistance, although the term is usually reserved for resistance to a substantial number of different antibiotic classes. In this study we have defined bacteria resistant to more than five antibiotic groups as multiresistant [99].

### **3.6 Quinolones; mechanism of action**

The quinolones inhibit bacterial DNA synthesis by interfering with the action of two essential bacterial enzymes, DNA gyrase and topoisomerase IV. Quinolones bind the DNA-enzyme complex of topoisomerase and the resulting drug-complex is trapped at the DNA cleavage stage thereby preventing strand re-joining [100]. In gram positive bacteria topoisomerase IV is the primary target while topoisomerase II (DNA gyrase) is the primary target in gram negative bacteria [100].

There are several proposed mechanisms of quinolone action. Drlica et al propose chromosome fragmentation as a cause of rapid death: Quinolone lethality can be described as a two-step process in which the first step is reversible (bacteriostatic) formation of cleaved complexes. This step blocks bacterial DNA replication, induces the SOS response, and leads to cell

filamentation. Although these events do not appear to be rapidly lethal, their involvement in slow death has not been ruled out. In a second, lethal step that requires higher quinolone concentrations, DNA breaks are released from constraint by at least two processes. The relative contribution of each pathway to cell death depends on quinolone structure, with the older quinolones requiring protein synthesis and some new fluoroquinolones functioning without it [101]. Toxin-antitoxin modules have also been proposed to contribute to quinolone lethality [101].

### **3.7 Quinolone resistance mechanisms**

Quinolone resistance is mainly due to chromosomal mutations altering the drug targets or reducing the drug accumulation in the cell by up regulating efflux or down regulating influx. Resistance arise in a stepwise manner and multiple mutations are often required to generate clinical resistance [102].

Plasmids harbouring genes coding for quinolone resistance have been known since the 1990s [24].

#### **3.7.1 TARGET-ENZYME RESISTANCE**

The quinolone binding region in the target enzymes DNA-gyrase and topoisomerase IV is termed the “quinolone-resistance-determining region” (QRDR). Mutations in this region may lead to decreased binding of quinolones or impair target enzyme function reducing the formation of enzyme-DNA complex [103].

In *E. coli* DNA-gyrase is more susceptible to quinolones than Topoisomerase IV and resistance mutations arise first in the GyrA subunit of DNA-gyrase between amino acid positions 51 and 106 with hotspots at amino acid position 83 and 87. The resistance builds up in a stepwise manner. Once a first-step mutation has reduced the susceptibility to quinolone, additional mutations in GyrA, GyrB (subunit of gyrase) and ParC (subunit of topoisomerase IV) have been shown to further increase the minimal inhibitory concentration (MIC) of quinolones. In *E. coli*, single mutations in *gyrA* hardly increase the MICs of fluoroquinolones and clinical level of resistance appears with a second mutation in *gyrA* or a mutation in *parC*. In general, the more resistant a clinical isolates, the more quinolone resistance-associated mutations it contains [103].

### 3.7.2 INFLUX-EFFLUX RESISTANCE

Resistance towards quinolones may be caused by increased efflux or decreased influx, resulting in lower intracellular quinolone concentrations. *E. coli* can regulate membrane permeability by altering expression of the passive diffusion proteins of the outer membrane proteins (OmpF). Meanwhile the AcrAB-TolC efflux pump plays a major role in quinolone efflux. This efflux pump has multiple controls and mutations in genes coding for these controls may increase pump activity. Such mutations may simultaneously decrease translation of OmpF and passive diffusion [103].

### 3.7.3 PLASMID-MEDIATED RESISTANCE

Low-level quinolone resistance may also be mediated by Plasmid-mediated quinolone resistance genes (PMQR). Plasmid mediated quinolone resistance was first described by Luis Martinez-Martinez et al. in the late 1990s. Three classes of genes, *qnr*, *aac* and *qep* are recognized [104].

#### **Qnr:**

Plasmids carrying *qnr* genes vary widely in size and associated resistances but almost all carry multiple resistance determinants. The *qnr* genes (*qnrA*, *B*, *C*, *D*, and *S*) code for pentapeptide-repeat family proteins a large protein family whose functions are poorly understood [104]. On the plasmids that have been studied, *qnr* has been mapped in an integron or integron-like structure near an element called “*orf513*.” Orf513 is believed to be a recombinase involved in site-specific acquisition of resistance genes [103].

The *qnr* genes by themselves provide only a low level of resistance to quinolones. However, the presence of *qnr* genes widens the mutant selection window by increasing the minimal prevention concentration (MPC) of ciprofloxacin by 10-fold (see 3.7.4), thus facilitating the selection of additional resistance mutations [103].

#### **Aminoglycosidase acetyltransferase (aac):**

The *aac* genes code for aminoglycosidase acetyltransferase. The *aac(6')-Ib-cr* gene encodes a variant aminoglycosidase acetyltransferase that inactivates hydrophilic quinolones such as ciprofloxacin in addition to aminoglycosides [105, 106].

#### **QepA:**

QepA is a plasmid-mediated fluoroquinolone efflux pump found in *E. coli* [107].



### 3.7.4 Mutation rate and MPC

Minimal prevention concentration (MPC) is the concentration that allows no mutants to emerge. During antibiotic therapy resistant mutants may develop using antibiotic concentration between the MIC and MPC named the mutant selection window by Zhao and Drlica in 2001[108].

Bacteria harbouring mutations leading to elevated MIC but no clinical resistance will have an elevated minimal prevention concentration (MPC) thereby making the acquisition of higher-level resistance easier. Hence, prior quinolone use is a risk factor for the later development of clinically significant resistance, and repeated use of the same agent increases the likelihood of therapeutic failure.

## 3.8 Multiresistant Fluoroquinolone resistant *E. coli*

Fluoroquinolone resistance in *E. coli* is associated with multiresistance [47, 99, 109-111]. The reason for this association is not completely investigated. Johnson et al conclude in their study from 2009 that resistance to tetracycline and fluoroquinolone has a prominent clonal component, with the O15:K52:H1 clonal group and especially *E. coli* ST131 being the major contributors. These clonal groups appear to be more virulent than comparably resistant isolates, possibly contributing to their success as emerging multi-drug-resistant pathogens [47]. In Australia, a large proportion (42%) of fluoroquinolone-resistant extra-intestinal *E. coli* isolates from humans are represented by three major globally disseminated clonal groups, predominantly ST131 and the majority of the isolates were multiresistant [111]. In Italy heterogeneity of MLST types was observed, with ST131 strongly predominant in human ciprofloxacin-resistant strains (58/135, 43.0%) [110].

In this study we found a strong correlation between quinolone resistance and multiresistance among *E. coli* from UTI. This association were found to be primarily non-clonal phenomena and the tendency to multiresistance applies also to quinolone resistant isolates that are not ciprofloxacin resistant [99].

### 3.8.1 SOS-driven evolution to antibiotic resistance

The SOS-response was discovered and named by Miroslav Radman in 1975 [112] and involves an error prone DNA-repair mechanism in bacteria in reaction to DNA damage. SOS-response leads to cell cycle arrest and DNA repair. The SOS-response is induced by

accumulation of ssDNA leading to *recA* activation by formation of filaments around the ssDNA and cleavage of LexA, the repressor of the SOS operon [113].

The regulation of integrase genes (*IntI*) involves the SOS response and SOS induction controls the rates of cassette recombination. Under normal conditions, repression of *intI* maintains integron cassettes in a steady state. Induction of the SOS response increases the exchange and recombination of gene cassettes.

Antibiotics known to induce the SOS response, such as trimethoprim, quinolones, and  $\beta$ -lactams, promote integrase expression and horizontal dissemination of antibiotic resistance genes [114, 115]. It has also been shown that ciprofloxacin, as one of the known antimicrobials that trigger the SOS-response, increase the frequency of mutations and thereby the chance for mutants resistant to ciprofloxacin [116].

A study by Da Re et al has demonstrated that ciprofloxacin induces expression of plasmid-borne quinolone resistant (*qnr*) genes in the Enterobacteriaceae via the SOS-response [117].

### 3.9 Virulence and virulence factors

Although *E. coli* is normally harmless, it is often diagnosed to be the cause of infection in patients suffering from diarrhoea, urinary tract infections, gastroenteritis and neonatal meningitis/sepsis. Pathogenic *E. coli* can be grouped into eight different pathovars broadly classified as either diarrhoeagenic or extraintestinal *E. coli* (*ExPEC*). Diarrhoeagenic; enteropathogenic (EPEC), enterohaemorrhagic (EHEC), enterotoxigenic (ETEC), enteroinvasive (EIEC), enteroaggregative (EAEC) and diffusely adherent (DAEC). Extraintestinal; uropathogenic (UPEC) and neonatal meningitis (NMEC). Other pathovars not as well studied have been described [118].

Pathogenic *E. coli* harbours certain factors associated with disease described as virulence factors. Each of the pathovars has its own mechanisms for attaching and overcoming the host defences and thereby causing disease. Adhesion to host cells is required in all infections caused by *E. coli* except EIEC. Adhesion is often achieved by appendages called fimbria or pili. Pathogenic *E. coli* also express certain traits to subvert host cell processes by secretion of proteins [119, 120].

## 4 The study

### 4.1 Aims

The primary aims of the following study are as follows:

- Survey clonal composition of quinolone resistant *Escherichia coli*
- Survey the nature of resistance mechanisms in quinolone resistant *Escherichia coli*
- Investigate the relationship between development of quinolone resistance and multiresistance in *Escherichia coli*
- Evaluate various methods for typing of *Escherichia coli*

### 4.2 Hypothesis

The following hypotheses have been tested:

- Quinolone resistant *Escherichia coli* are more clonal than quinolone sensitive isolates.
- Quinolone resistant *Escherichia coli* are more multiresistant than quinolone sensitive isolates.
- Multiresistance in quinolone resistant *Escherichia coli* is driven by linkage to plasmid mediated quinolone resistance.
- Multiresistance can be explained by multidrug resistant efflux mutations.
- Multiresistance in quinolone resistant *Escherichia coli* is associated with horizontal gene transfer.
- Multiresistance in quinolone resistant *Escherichia coli* can be explained by clonal spread of multiresistant strains.

### 4.3 List of papers

**Article 1:** Grude N, Potaturkina-Nesterova NI, Jenkins A, Strand L, Nowrouzian FL, Nyhus J, Kristiansen BE: **A comparison of phylogenetic group, virulence factors and antibiotic resistance in Russian and Norwegian isolates of Escherichia coli from urinary tract infection.** *Clinical microbiology and infection : the official publication of the European Society of Clinical Microbiology and Infectious Diseases* 2007, **13**(2):208-211.

**Article 2:** Grude N, Strand L, Mykland H, Nowrouzian FL, Nyhus J, Jenkins A, Kristiansen BE: **Fluoroquinolone-resistant uropathogenic Escherichia coli in Norway: evidence of clonal spread.** *Clinical microbiology and infection : the official publication of the European Society of Clinical Microbiology and Infectious Diseases* 2008, **14**(5):498-500.

**Article 3:** Strand L, Jenkins A, Grude N, Allum AG, Mykland HC, Nowrouzian FL, Kristiansen BE: **Emergence of fluoroquinolone-resistant clonal group A: clonal analysis of Norwegian and Russian E. coli isolates.** *APMIS : acta pathologica, microbiologica, et immunologica Scandinavica* 2010, **118**(8):571-577.

**Article 4:** Strand L, Jenkins A, Henriksen IH, Allum AG, Grude N, Kristiansen BE: **High levels of multiresistance in quinolone resistant urinary tract isolates of Escherichia coli from Norway; a non clonal phenomenon?** *BMC research notes* 2014, 7:376.

**Article 5:** Linda Strand, Andrew Jenkins, Nina Narmoe, Beate Kiland Langerud , Anne Gry Allum, Nils Grude, Bjørn Erik Kristiansen: **Resistance Mechanisms in multiresistant fluoroquinolone resistant Escherichia coli at an early stage of the emergence of ciprofloxacin resistance in Norway.** (Manuscript ready for submission).

**Report:** Amplified Fragments Length Polymorphism (Annex 1).

Article 2-5 are extensively based on the MS-thesis of Nina Narmoe Egeberg [121], Beathe Kiland Langerud [122] and Hilde Mykland [123].

Article 1 and 2 are also a part of PhD thesis Urinary tract infections with emphasize on bacterial etiology, sensitivity, virulence and clonal distribution by Nils Grude [124].

## 4.4 Summary of material and methods

Table 3: Summary of materials and methods in this study.

Materials	Clonal affinity					Virulence	MIC		Resistance mechanisms			
	AFLP	PFGE	Ribo	Phylo	CgA		E-test	Agar	QRDR	PMQR	Efflux	Transfer
Russian UTI <i>E. coli</i> 2001 (N=31)		X	X	X	X*	X	X					
Norwegian UTI <i>E. coli</i> 2001 (N=31)		X	X	X	X*	X	X					
Intestinal <i>E. coli</i> 2001 (N=138)		X	20**	20**	X*	20**	20**					
ciproR UTI <i>E. coli</i> 2003 (N=35)	X	X	X	X	X*	X	X		X	X	X	X
NalS UTI <i>E. coli</i> 2005 (N=43)		X		X	X*		X	X		X	20***	
NalR UTI <i>E. coli</i> 2005 (N=150)		X		X	X*		X	X		X	40***	

X, all isolates, X\*, All phylo D, 20\*\*, 20 different clones identified by unique PFGE patterns, 20\*\*\*, mic cipro 0.016-0.032, 40\*\*\*, 20 mic cipro 0.25-1.0 and 20 mic cipro 16-250 mg/L

### Materials:

1. *Russian UTI E. coli*: 31 Russian *E. coli* from uncomplicated urinary tract infections; isolated in 2001.
2. *Norwegian UTI E. coli*: 31 Norwegian *E. coli* from uncomplicated urinary tract infections; isolated in 2001.
3. *Intestinal E. coli*: 138 intestinal isolates from ten healthy women collected during colonoscopy screening; isolates in 2001.
4. *CiproR UTI E. coli*: 35 Norwegian ciprofloxacin resistant *E. coli* from uncomplicated urinary tract infections; isolates in 2003.
5. *NalS UTI E. coli*: 43 Norwegian nalidixic acid sensitive *E. coli* from uncomplicated urinary tract infections (MIC Nal < 16 mg/L); isolated in 2005.
6. *NalR UTI E. coli*: 150 Norwegian nalidixic acid resistant *E. coli* from uncomplicated urinary tract infections (MIC Nal ≥ 16 mg/L); isolated in 2005.
7. *Other strains/Control strains*  
- qnrA positive strain, J53 pMG252 (Jacoby) [125].

- *qnrB/S* positive strain (L. Poirel and P. Nordmann, Cattoir et al 2007) [126].
- *aac(6')*-*lb-cr* positive strain (L. Poirel and P. Nordmann, Cattoir et al 2007) [126].
- *E. coli* reference ATCC 25922 for quality control MIC.

## Methods:

### 1) Clonal affinity

- a) AFLP (Amplified fragments Length Polymorphism) [74].
- b) PFGE (Pulse Field Gel electrophoresis): *Xba*I restriction patterns were compared using GelCompar II software (Applied Maths) [72].
- c) Ribo (Ribotyping): *EcoRI* ribotype patterns were compared using GelCompar II software [66].
- d) Phylogenetic group: triplex PCR (*chuA*, *yjaA*, and *TSPE4.C2*) [41].
- e) CgA (Clonal group A): *fumC* C288T detection by PCR [127].

### 2) Virulence

Type 1 fimbria, P fimbriae, Dr Heamagglutinin, S fimbriae, K1 capsule, K5 capsule, aerobactin and haemolysin detection by multiplex PCR [128].

### 3) Minimal inhibition concentration (MIC)

- a) E-test (AB Biodisk, Solna, Sweden): The sensitivity to mecillinam, trimethoprim, nitrofurantoin, ampicillin, sulphonamide, ciprofloxacin, nalidixic acid, chloramphenicol, tetracycline and gentamicin/kanamycin agent was tested.
- b) Agar (Agar dilution): The sensitivity to mecillinam, trimethoprim, nitrofurantoin, ampicillin, sulphonamide, ciprofloxacin, nalidixic acid, chloramphenicol, tetracycline and gentamicin/kanamycin agents were tested on iso-sensitest medium (Oxoid, Basingstoke, England).

### 4) Resistance mechanisms

- a) Quinolone resistance determining regions (QRDR): *gyrA* mutation detection by Sanger sequencing [129].
- b) Plasmid mediated quinolone resistance genes (PMQR): *qnrA/B/S* and *aac(6')*-*lb-cr* were detected by PCR [130, 131].
- c) Increased efflux: upregulated AcrAB-TolC efflux pump was assessed by organic solvent tolerance [132].

- d) Transferable resistance (transfer): Cross-streak mating was used as a measure of resistance- plasmid transferability [122].

## 4.5 The main results

### Antibiotic resistance in *Escherichia coli*:

- Norwegian UTI *E. coli* were frequently resistant to ampicillin, tetracycline and sulphonamide but otherwise mostly sensitive to antibiotics [133].
- UTI isolates were more resistant to ampicillin, tetracycline, sulphonamide and ciprofloxacin than intestinal isolates[133].
- Ciprofloxacin MIC followed a trimodal distribution peaking at 0.032 mg/L (nalidixic acid sensitive isolates), 0.5 mg/L and 64 mg/L (nalidixic acid resistant isolates) [99].
- Quinolone resistant isolates were much more resistant to other antibiotics than quinolone sensitive isolates [99, 134].
- Strains were much more multiresistant than quinolone sensitive isolates [99, 134].
- Isolates expressing upregulated multidrug resistant efflux were not significantly more multiresistant [135].
- There was no apparent association between clonal affinity and resistance patterns [99].

### Phylogenetic distribution:

- UTI *E. coli* belonged mainly to phylogroup B2 and D, whereas intestinal strains predominantly belonged to group A and B1[133].
- Quinolone resistance was positively correlated with phylogroup D and negatively correlated with Phylogroup B2 [99].

### Clonal relationship detected by PFGE:

- UTI *E. coli* were genetically heterogeneous with 125 unrelated PFGE patterns found among 183 isolates (nalidixic acid sensitive and resistant isolates from 2005) [99].
- 43% (78/183) of these isolates were associated with a clonal group defined by PFGE [99].
  - The two largest clonal groups contained 12 isolates each.
  - One of these clonal groups belonged to phylogroup D and was identified as CgA.

- The other group belonged to phylogroup B2 and included four isolates from a suspected outbreak at a home for elderly.
- PFGE group correlated 100% to the phylogroups.
- Five clonal groups persisted from 2003 to 2005. The two largest clonal groups from 2005 were among the persistent clonal groups [99, 136].
- Some clonal groups were associated with quinolone resistance [99].
- Some clonal groups were associated with quinolone sensitivity [99].
- No clonal groups encompassed highly ciprofloxacin resistant isolates and quinolone sensitive isolates [99].
- Quinolone resistance was not preferentially associated with clonal isolates [99].
- Quinolone resistant isolates were not more clonal than quinolone sensitive isolates [99].

#### **Clonal group A:**

- The globally distributed urovirulent clonal group A (CgA) was detected for the first time in Norway [134].
- 19% (N=31) of Norwegian *E. coli* UTI from year 2001 were CgA; none were resistant to quinolones [134].
- The first reported quinolone resistant CgA isolates worldwide were found among ciprofloxacin resistant UTI isolates from 2003 [134].
- Some CgA isolates were multiresistant [99, 134].
- CgA isolates shifted from 100% quinolone sensitive in 2001 to 100% quinolone resistant in 2005 [99].

#### **Ribotyping [134]:**

- Ribotyping was performed on 117 isolates (Russian UTI and Norwegian UTI and intestinal isolates).
- The 46 ribotypes could be grouped into seven clusters (ribogroups). Four groups (A, B, C and G) dominated.
- Phylogroup was strongly but not absolutely correlated with ribotype and ribogroup.
- CgA isolates were found in three of the four main ribogroups, mainly ribogroup G.
- One of the dominant ribogroups (ribogroup C) carried significantly more virulence factors than the other groups and most of these isolates belonged to phylogroup B2.



- No dominant resistance pattern could be seen within the various ribogroups.
- Norwegian UTI isolates were preferentially ribogroup C, Russian UTI ribogroup B and ciprofloxacin resistant UTI ribogroup A. Intestinal isolates were more evenly distributed between the ribogroups.

#### **AFLP (Annex 1):**

- AFLP profiles contained 50 to 85 fragments in the size range 35 to 450 base pairs.
- All but two of the 35 profiles were different.
- Profiles clustered into 29 groups at a 95% similarity level.
- Isolates with similar AFLP patterns had similar PFGE patterns. Some isolates had similar PFGE patterns but dissimilar AFLP patterns.

#### **Quinolone resistance mechanisms [135]:**

- Sequencing of *gyrA* revealed the recognized resistance mutations 83 Ser and 87 Leu in all the 35 ciprofloxacin resistant isolates from 2003.
- Plasmid mediated quinolone resistance was uncommon.
  - *aac(6')-Ib-cr* was found in three of thirty five ciprofloxacin resistant isolates from 2003.
  - *qnrS* was found in one of one hundred and fifty nalidixic acid resistant isolates from 2005.
- 27% of the ciprofloxacin resistant UTI isolates showed organic solvent tolerance consistent with upregulated efflux activity.
- Only ciprofloxacin resistant isolates showed organic solvent tolerance.

#### **Transferable resistance [135]:**

Transferable resistance was detected at a high rate (15/55) among ciprofloxacin resistant isolates.

## 4.6 Discussion and conclusion

**Selection of materials:** The materials in this study are primarily from urinary tract isolates. Urinary tract infections are common and *E. coli* is the most frequent cause. However, UTI isolates have been less intensively studied than enteropathogenic and invasive isolates. Most of the isolates are from females with the most prevalent group of patients with urinary tract infections [8-10].

The selection of strains in this study is local, from a single county in Norway; and collection periods were during a five years period from 2001 to 2005. The prevalence of fluoroquinolone resistance among invasive isolates in Norway during this period was very low compared to southern European countries [5]. This is thus a study of fluoroquinolone resistance in its emerging phase. However, its direct relevance to the present-day situation may be questioned. Most others have investigated fluoroquinolone resistant *E. coli* from a wider area and the prevalence of fluoroquinolone resistance has been high.

As isolates were collected locally and consecutively this study is optimised for finding local outbreaks. This increases the likelihood of detecting clones.

The largest collected material from 2005 included isolates sensitive to nalidixic acid, resistant to nalidixic acid but sensitive to ciprofloxacin and isolates resistant to ciprofloxacin to make it possible to investigate if fluoroquinolone resistant isolates were more clonal and multiresistant and to make statements about the quinolone resistant mechanisms.

The reference group of intestinal isolates was collected in connection with colonoscopy of healthy women. Many samples yielded little or no *E. coli* colonies, which suggest that only a selected subset of the *E. coli* population survive preparations for colonoscopy.

The Russian isolates were from younger women and from patients with a broader range of clinical conditions compared to the Norwegian and may not be strictly comparable [133].

### **Antibiotic resistance:**

Fluoroquinolone resistance in *E. coli* is highly prevalent in many European countries while in Norway it remains an emerging phenomenon [5].

We investigated resistance to classes of antibiotics:  $\beta$ -lactams (ampicillin and mecillinam), tetracyclines (tetracycline), sulphonamide (sulfamethoxazole), trimethoprim, amphenicols (chloramphenicol), aminoglycoside (gentamicin or kanamycin) and nitrofurantoin in addition to the quinolone nalidixic acid and fluoroquinolone ciprofloxacin. These antibiotics were

investigated either because they are used in treatment of *E. coli* infections or because they are frequently associated with genetic elements encoding multiresistance. MIC (minimum inhibitory concentration) was measured by E-test and agar dilution. E-test is a commercial test easy and fast but greater precision may be achieved by using agar dilution which is further one of the method of reference. For larger collections of isolates agar dilution may also be a more effective method to measure MIC.

We found that intestinal isolates are less resistant than UTI isolates. An explanation for this might be that the UTI isolates, being pathogenic, are more likely to have been previously exposed to antibiotics.

The high sensitivity to antimicrobials in Norwegian *E. coli* UTI compared to countries in southern Europe [5] may be explained by the low consumption of antibiotics, controlled use and limited use as growth promoters in agriculture resulting in low selection pressure.

Underlying diseases, quality of hospital care, immunization rates and social factors may also explain the difference in rates of resistance [5]. Consumption of antibiotics in Norway have increased but still remains low compared to countries in southern Europe [137].

We observed a trimodal distribution of ciprofloxacin resistance with an intermediate peak ranging from 0,125 to 4 mg/L including isolates sensitive, intermediate and resistant to ciprofloxacin and nalidixic acid resistant. Thus, isolates with ciprofloxacin MICs as low as 0.125 are nalidixic acid resistant and, according to the stepwise model of ciprofloxacin resistance [103, 138], have the potential to evolve to full resistance. A similar pattern has been reported for *Salmonella* isolates [139]. EUCAST guidelines mention poor treatment response for invasive infections for *Salmonella* isolates with ciprofloxacin MICs  $\geq 0.125$  and that such isolates should be regarded as potentially ciprofloxacin resistant [95]. Our results suggest the same may apply to *E. coli*. A study by Marcusson et al in 2009 suggests that mutant *E. coli* with low level of fluoroquinolone resistance may evolve to high level resistant isolates by natural selection for improved growth rate without further exposure to fluoroquinolones [20].

#### **Phylogenetic distribution:**

*E. coli* has six recognized phylogroups of which A, B1, B2 and D are the most common and these are the phylogroups investigated in this study.

Virulent extra-intestinal strains of *E. coli* belong mainly to phylogroups B2 or D, whereas commensal strains belong predominantly to groups A and B1 [44, 127]. Norwegian UTI isolates conformed to this pattern [136].

As in other studies, we find a significant correlation between quinolone resistance and phylogenetic group, with phylogenetic group D being positively correlated with quinolone resistance, as previously observed by Johnson et al [140, 141] and phylogenetic group B2 being negatively correlated, as observed in all previous comparisons [140-142]. However, in contrast to the other studies we do not find a significant positive correlation with phylogenetic group A. In view of the moderate magnitude of the correlations observed and the moderate sample sizes, differences between studies are not unexpected. We find that correlation between ciprofloxacin resistance and phylogroup is confined to non-clonal isolates, which implies phylogroup-specific differences in propensity to acquire ciprofloxacin resistance, rather than an effect of clonal spread, as previously suggested [42, 136].

The phylogenetic typing used in this project is based on three single loci used as surrogate markers for phylogenetic relationship [41]. This is a fast and easy way to investigate phylogenetic background of the isolates but MLST involving sequencing of seven housekeeping genes or whole genome sequencing would have been more accurate methods. MLST provides a large amount of highly comparable information (sequence of about 500 basepairs in seven housekeeping genes) giving the method greater phylogenetic depth and higher power of discrimination [68, 143].

### **Typing methods:**

**Ribotyping** is a restriction fragment length polymorphisms analysis (RFLP) of the highly conserved ribosomal RNA genes and their flanking DNA. Bouchet et al argue that that ribotyping is a good typing method for investigating phylogenetic relationship because the flanking genes are typically neutrally evolving housekeeping genes [144]. Different ribotypes are assumed to evolve through random point mutations in the genes flanking the ribosomal operons and thereby resulting in gain or loss of restriction sites [144]. *E. coli* is known to harbour seven operons of ribosomal genes and ribotyping patterns will therefore reflect the position of restriction sites in the various flanking genes [144].

In this study we have used an automated version of Ribotyping (Riboprinting) [66] where *E. coli* isolates showed 10 to 15 bands ranging from 1 to 50 kbases per isolate. Norwegian and Russian UTI *E. coli*, ciprofloxacin resistant *E. coli* and intestinal *E. coli* isolates grouped into

four dominating ribogroups (95% internal similarities) comprising 82% of the isolates. One group was dominated by Norwegian UTI, one by Russian UTI, one by ciprofloxacin resistant isolates and one by isolates belonging to the globally distributed clonal group A. This indicates that Russian UTI isolates are phylogenetically distinct from the Norwegian isolates and that ciprofloxacin resistant isolates have evolved from strains phylogenetically distinct from sensitive UTI isolates in Norway. This is also indicated by our clonal analysis by PFGE where no clones were shared by nalidixic acid sensitive and ciprofloxacin resistant isolates [99]. Intestinal isolates were more phylogenetically diverse distributed among ribogroup A, B and C.

The four main ribogroups were compared to the four phylogenetic groups A, B1, B2 and D; Ribogroup A contained 48% phylogroup B2, ribogroup B 91% phylogroup A, ribogroup C 61% phylogroup B2 and ribogroup G 85% phylogroup D.

73% (8/11) of the CgA isolates belonged in ribogroup G but unexpectedly some CgA grouped in other ribogroups.

Exactly identical ribotypes may belong to different phylogenetic groups. This phenomenon indicates either that ribotyping is not well suited for detecting phylogenetic genetic relatedness or that triplex PCR used for phylogrouping is not as specific as earlier validations have estimated [41]. In contrast to ribotyping every PFGE class was entirely homogeneous with respect to phylogroup, even though more isolates were analysed by PFGE. This indicates that ribotyping is less well suited for analysing genetic relatedness. Furthermore, ribotyping does not discriminate as well as PFGE. All CgA isolates belonged to the same PFGE clonal group; this was not the case for ribotyping.

Methods such as identification of CgA by the *fumC* C288T are single locus methods and it is thus natural to suspect their reliability. However, Johnson et al reported 100% sensitivity and specificity for detection of CgA using *fumC* C288T detection compared to ERIC2 PCR and random amplified polymorphic DNA (RAPD) analysis of 138 diverse clinical and reference *E. coli* isolates [127]. The triplex PCR for phylogenetic grouping was evaluated by testing 230 strains that had already been grouped by using reference methods and obtained an accuracy of more than 99% compared to the reference method [41]. This seems to be borne out by our PFGE results.

**AFLP** separates isolates based on differences in distribution of close pairs of restriction enzyme sites over the total genome modulated by selective primer sets for amplification by PCR. The restriction enzymes we used (*MseI*, four cutter and *EcoRI*, six cutter) were pre optimised for *E. coli* by others [145].

Typing of 35 ciprofloxacin resistant isolates by AFLP resulted in amplification of 50 to 85 bands per isolate with good resolution of band patterns. AFLP gave the highest discriminating power of the techniques we used and only two of the isolates shared identical band patterns. AFLP have been reported as highly reproducible and a typing method with high discriminating power by others [74, 145].

We found the large number of bands and the appearance of uncertain band made the analytic work relative complicated and time consuming. Decreasing the number of bands can be done by adding bases to the selective primers [145]. The reasons for uncertain bands might possible be due to poor DNA quality leading to partial cutting by the restriction enzymes, unspecific amplification or variable amplification efficiency.

**PFGE** differs from conventional agarose gel electrophoresis in the use of periodic switching of the electric field during electrophoresis which allows separation of large fragments of DNA. The whole genome was cut with restriction enzyme with low frequency cut sites using *XbaI* which have been evaluated for *E. coli* by others to give about 20 bands ranging from 10 to 700 kbases [73].

We defined a clonal group as all the isolates differing by six bands or less from the first band pattern investigated in the group [73]. This way of including isolates in clonal groups may exclude some single members or lead to separation of two clonal groups which in nature are in closely related.

A drawback of PFGE was that not all isolates were typable. 30% of the 35 isolates resistant to ciprofloxacin in 2003 were degraded and could not be typed by PFGE. This phenomenon has been reported in other studies as well [145-147] and studies by Silbert et al 2001 [146] report that adding thiourea in the buffer during electrophoresis increase the typing ability. According to Ray et al [148] the increased typability by adding thiourea indicate that the degradation of DNA is because of degradation by tris radicals during electrophoresis and not by proteinase K resistant DNases or other proteins involved in the DNA-stability. Ten isolates were non-typable by PFGE despite adding thiourea during electrophoresis [99].

## Clonal relationship

We tested two typing methods for clonal analysis; PFGE and AFLP. PFGE was the method we choose to use for clonal analysis as it gave more, larger clonal groups and was easier to analyse. Our goal was to look for related isolates rather than exactly identical ones.

Doing outbreak investigation would call for typing methods separating down to identical isolates and exact clones. AFLP separated the isolates best and would then be the preferred method.

We have previously proposed that fluoroquinolone resistant isolates are more clonal than sensitive isolates on the basis of a clonal analysis of ciprofloxacin sensitive UTI isolates from 2001 and 35 isolates resistant to ciprofloxacin from 2003 [136]. Analysis of the material from 2005 using a more comparable control group of quinolone sensitive isolates showed that the degree of clonality among quinolone resistant and sensitive isolates was equal. There were some clonal groups associated with quinolone resistance even though quinolone resistance was not preferentially associated with clonal isolates.

The four largest clonal groups among quinolone resistant isolates, clones 1, 2 (CgA), 3 and 5 belonged to the uropathogenic phylogenetic groups B2 and D and comprised 25% of the isolates. The clonal groups did not display uniform resistance patterns, although 100% of clone 3 and 66% of clone 2 (CgA) isolates were trimethoprim-sulphonamide resistant. Cagnacci et al. assigned 34% of 148 ciprofloxacin resistant isolates to two clonal groups using multilocus sequence typing (MLST) [42]. This is apparently a higher degree of clonality than we observe despite their collection being trans-European and collected over a four year period. MLST can however detect lower levels of clonal similarity than PFGE.

In our material, CgA comprised 19% (6/31) of ciprofloxacin sensitive UTI isolates from 2001, which suggests that it may be a significant cause of urinary tract infections in our locality. In contrast, just one of forty-eight Swedish *E. coli* isolates from 2001 belonged to CgA, although the proportion of UTI isolates in that material was not reported [44]. In 2003 we found two CgA isolates among ciprofloxacin resistant UTI *E.coli* and both were highly multiresistant. The change to quinolone resistant CgA isolates was further confirmed by investigating isolates from 2005 where all the CgA isolates were resistant to quinolones. Most of the isolates belonging to CgA showed intermediate resistance to ciprofloxacin, making them possible candidates for natural selection for improved fitness and thereby increased resistance towards fluoroquinolones as described by Marcusson et al [20].

CgA was one of the most prevalent of the clonal groups associated with quinolone resistance in our material. The CgA group has primarily not been described as resistant to quinolones. This study is the first to demonstrate the shift from quinolone sensitive to quinolone resistance that Johnson anticipated by analogy with the closely related 015:K52:H1 clonal group [44]. A quinolone resistant CgA isolate is also described in a table by Johnson et al in 2009 although this is not remarked in the text [47].

Interestingly the isolates non-typable by PFGE despite adding thiourea were all ciprofloxacin resistant, phylogroup D, and lactose non-fermenting; they are thus phenotypically similar to isolates of the 015:K52:H1 clonal group described by Cagnacci et al [42].

Some of the globally distributed clonal groups have been associated with specific resistance patterns, but there are few of these clones associated with quinolone resistance, except detection of clonal groups associated with fluoroquinolone and multidrug resistance in Italy by Giufre et al [110]. In our material some of the most abundant clones were associated with quinolone resistance. However, the efficiency of detecting clones is expected to increase with the number of isolates, so we cannot exclude the possibility that this is a statistical artefact resulting from more quinolone resistant than quinolone sensitive isolates being investigated.

Resistance to other antibiotics did not correlate with the clonal groups and this may be explained by the fact that isolates of the clones we have detected have been separated some time ago and loss and gain of genetic elements and possible mutations have taken place after their separation. Resistance patterns are often reported to be related to certain clonal groups [45] but this may partly be due to the fact that projects often look for clonality in specific groups of isolates with resistance towards these specific resistance patterns.

### **Existence of clones:**

Certain clonal groups are more abundant than others indicating that these are well adapted to the environment where we have isolated them and that they are capable of spreading between individuals harbouring them. The specific factors and routes for spreading are not known but transmission through animals, wastewater and humans has been proposed [14, 43, 110, 149-152]. We [99, 136] and others have reported evidence of clonal outbreaks of UTI among humans [13, 43, 44, 46, 47, 50, 111]. Abundant clonal groups isolated from UTI would be expected to harbour certain virulence factors making them capable of moving up the urinary tract and staying there.



Five of the quinolone resistant PFGE clones persisted from 2003 to 2005. CgA was not surprisingly one of the most abundant and persistent clones in our material because this clone is known to be global distributed and found among UTI isolates since 1990[43]. Persistence of UTI clones indicate that there are some “well suited” clones that may be spread and cause infection in different individuals. It may be suggested that these well adapted clones will frequently experience exposure to antibiotics. Bacteria undergoing mutations leading to resistance would be selected and eventually multi-resistant isolates would arise.

### **Quinolone resistance mechanisms:**

Fluoroquinolone resistance develops in a stepwise matter where mutations of DNA-gyrase is supposed to be the first step [102]. The sequence of the quinolone resistance determining region (QRDR) of *gyrA* confirmed the presence of commonly formed substitutions S83L and D87N in 32/35 ciprofloxacin resistant isolates. The remaining three ciprofloxacin resistant isolates had S83L accompanied by D87G, D87Y and D87H respectively [4, 153, 154]. Membrane permeability may also contribute to fluoroquinolone resistance. *E. coli* regulate membrane permeability by altering expression of passive diffusion proteins in the outer membrane or increasing efflux by upregulating the AcrAB-TolC efflux pump. Mutations in the control region for expression of these genes may increase efflux. Increased efflux by AcrAB-TolC leads to increased tolerance to cyclohexane [4, 103]. We measured tolerance for cyclohexane in isolates sensitive to quinolones, intermediate resistant and highly resistant to ciprofloxacin. Increased efflux was found among 27% (15/55) of the isolates highly resistant to ciprofloxacin and not among other isolates. This observation is in accordance with earlier reports that mutations which affect the regulation of influx/efflux happen after the initial mutations in DNA-gyrase/topoisomerase IV [103]. Up-regulated efflux pumps carry significant fitness costs and further mutations may increase both fitness and ciprofloxacin resistance without antibiotic pressure [20]. Our results showed that all the isolates with up-regulated efflux also had two mutations in *gyrA*. And insofar as the results of Marcusson et al [20] may be considered to apply to all strains of *E. coli*, we might expect a fourth or fifth mutation giving rise to even higher fluoroquinolone resistance and improved fitness.

A similar argument applies to our strains with intermediate resistant to ciprofloxacin which might be expected to evolve higher degree of resistance through fitness compensation without further selection pressure.

Plasmid mediated quinolone resistance (PMQR) was discovered in the late 1990s and is known to provide a low level of resistance to quinolones which widens the mutant selection windows and facilitating selection of additional resistance mutations. We screened for plasmid mediated *qnrA*, *B* and *S* in addition to the aminoglycosidase acetyltransferase gene coding for a variant that inactivate hydrophilic quinolones (*aac(6)-Ib-cr*) and found a very low abundance. Thus plasmid mediated quinolone resistance in the Norwegian quinolone resistant isolates cannot account for the increasing quinolone resistance in UTI isolates in Norway. The low abundance of PMQR in Norwegian isolates was confirmed by Karah et al [155]. In other countries where quinolone resistant *E. coli* is endemic, the abundance of these plasmids is much higher [3, 104, 156, 157]. The low abundance of PMQR in Norway may narrow the population based mutation window and partially explain the low prevalence of clinical quinolone resistance.

### **Multiresistance:**

This study confirms earlier reports [47, 109, 110, 136, 158, 159] of an association between ciprofloxacin resistance and resistance to other antibiotics, frequently in the form of multiresistance. We explicitly addressed this phenomenon in this project. We have also investigated the multiresistance among isolates with intermediate resistance to ciprofloxacin or other fluoroquinolones.

Association was found with resistance to ampicillin, tetracycline, sulphonamide, trimethoprim and chloramphenicol. This applies not only to ciprofloxacin resistant isolates but also to nalidixic acid resistant isolates with low ciprofloxacin resistance levels. This indicates that multiresistance arises at an early stage in the stepwise development of ciprofloxacin resistance. As far as we are aware, association between nalidixic acid resistance and multiresistance has not previously been reported [99].

Multiresistance may result from elevated efflux by the AcrAB-TolC multidrug efflux pump. 27% of isolates highly resistant to ciprofloxacin showed organic solvent tolerance indicating elevated efflux. However isolates showing intermediate resistance did not show elevated efflux. Multiresistance among the latter isolates cannot be explained by elevated efflux and up-regulated efflux therefore seems to be a late event in the development of fluoroquinolone resistance. Elevated efflux was not significantly correlated with multiresistance [135].

Plasmid mediated quinolone resistance have been coupled to plasmids harbouring other resistance genes [104, 160]. These plasmids could therefore explain why quinolone resistant

isolates are multiresistant. The low abundance of plasmid mediated quinolone resistance in our isolates indicates that these plasmids cannot explain the multiresistance among our isolates.

Genes coding for resistance are often located on plasmids and these plasmids can be transferred from one bacterium to another [81]. We investigated the prevalence of transferable plasmids in isolates resistant to ciprofloxacin by cross streak mating and found that 40% of the isolates harboured transferable resistance-plasmids. The high prevalence of transferable resistance indicates that this mechanism is important in development of multiresistance in quinolone resistant isolates. We have not yet investigated the rate of transferable resistance among the isolates intermediate resistant to ciprofloxacin which would be of great interest to know in view of the fact that multiresistance is an early event in building up resistance towards quinolones.

The most prevalent multiresistance pattern displayed (ampicillin, tetracycline, sulphonamide, trimethoprim and chloramphenicol) is typically associated with transposable elements suggesting an association between quinolone resistance and transposable elements. This association lends credence to the idea that multiresistance arises by the mobilisation of transposable elements caused by induction of the SOS response during quinolone therapy, an effect that has been suggested by Walsh [161].

The predominant multiresistance phenotype resembles the resistance pattern described in outbreak strains of O15:K52:H1 and CgA. The resistance genes giving the dominant resistance phenotype have been located in a chromosomal integration hot spot in CgA by Lescat and coworkers [162]. Three of 12 CgA isolates in this study exhibited this phenotype. Other authors also have reported resistance against streptomycin as one of the dominant resistances [45, 49, 162]. We have not tested for this antimicrobial agent.

CgA isolates are known to be typically multiresistant [45, 49, 162], and fluoroquinolone resistance is also associated with multiresistance, which makes the question of the potential for super resistance in fluoroquinolone-resistant CgA pertinent. The quinolone resistant CgA isolates in our material were not more multi-resistant than other quinolone resistant isolates although two isolates from 2003 were in fact superresistant, and one was fully resistant to all antimicrobials tested except mecillinam, to which it was only intermediately susceptible. Should such isolates become widespread they may cause serious problems for the treatment of urinary tract infections [134]. Superresistant CgA was also found in 2005 in one isolate [99].

## 4.7 Main conclusions/further work

### The following hypotheses were confirmed:

- Quinolone resistant *Escherichia coli* are more multiresistant than quinolone sensitive isolates
- Multiresistance in quinolone resistant *Escherichia coli* is associated with horizontal gene transfer

### The following hypotheses were rejected:

- Quinolone resistant isolates are more clonal than quinolone sensitive isolates
- Multiresistance in quinolone resistant *Escherichia coli* is driven by linkage to plasmid mediated quinolone resistance
- Multiresistance in quinolone resistant *Escherichia coli* can be explained by clonal spread of multiresistant strains
- Multiresistance can be explained by multidrug resistant efflux mutations

### Conclusion:

#### Phylogroup:

- Quinolone resistance was positively correlated with phylogroup D and negative correlated with phylogroup B2.
- Ribotype was not closely correlated with phylogroup; Ribotyping separated the isolates into four main ribogroups representing:
  1. Russian UTI isolates mostly phylogroup A
  2. Norwegian UTI isolates, mostly phylogroup B2
  3. Ciprofloxacin resistant UTI isolates, belonging to diverse phylogroups
  4. CgA, mostly phylogroup D.

#### Clonality:

- AFLP discriminated more than PFGE but PFGE enable better grouping of clonal related isolates.
- Clonal analysis by PFGE revealed some abundant clones coupled to quinolone resistance, one of which was the globally distributed CgA.
- CgA in our materials has evolved from nalidixic acid sensitive in 2001 to resistant in 2005.

### **Quinolone resistance mechanisms:**

- Two genomic mutations in *gyrase* previously shown to give clinical resistant phenotypes were found in isolates resistant to ciprofloxacin.
- Increased efflux was detected among 27% of the ciprofloxacin resistant isolates.
- No increased efflux was found among the isolates intermediate resistant to ciprofloxacin.
- Plasmid mediated quinolone resistance was not abundant.

### **Multiresistance in quinolone resistant isolates:**

- Arises in isolates resistant to nalidixic acid before the isolates become resistant to ciprofloxacin.
- Is not explained by multiresistant clonal groups.
- Is not explained by multiresistance plasmids harbouring quinolone resistance.
- Is not explained by increased efflux.
- May be explained by the high degree of transferable resistance.

### **Further work:**

#### **Surveillance of quinolone resistance**

This study was done using isolates from 2001 to 2005 where the prevalence of fluoroquinolone resistant *E. coli* isolates were lower than today. The prevalence has increased from 1,3% in 2001 to 11,3 % in 2012 in Norway [5]. It is important to follow up with prevalence studies of quinolone resistant isolates like the one done by European Centre for Disease Prevention and Control (ECDC) [5]. It would also be of great interest to survey the prevalence of plasmids harbouring quinolone resistance genes (PMQR), spread of clonal groups and multiresistance among pathogenic *E. coli* in Norwegian isolates today.

#### **Clonal spread**

We showed that the international clonal group A (CgA) were one of the most prevalent clonal groups in Norway. Using MLST, recently a more standardized typing method, might help us to identify more known pathogenic clonal groups found in Europe and rest of the world [42, 43, 47, 52].

## **Plasmid characterization**

The fact that quinolone resistant isolates were much more resistant to other antibiotics is an important finding. The reason for this was investigated in our study but we did not resolve the question fully. We found that multiresistance arose at an early stage in the development of quinolone resistance and that the isolates showing a high degree of fluoroquinolone resistance harboured significantly more transferable resistance plasmids than sensitive commensals. Our results would be more complete if we knew the degree of transferable resistance in pathogenic isolates sensitive or intermediate resistant to fluoroquinolones and further investigated the plasmids found among the multiresistant isolates.

Investigation of the plasmids in quinolone resistant isolates by incompatibility typing or plasmid-sequencing would give an opportunity to further understand why the isolates are multiresistant.

## **Mobilization of resistance plasmids**

We found that plasmids were transferred between *E. coli* isolates by selection of other antibiotics than quinolones, but investigate plasmid mobilization by quinolone treatment would tell us even more. Quinolone is one of the antibiotics known to trigger the SOS response [22]. The SOS response leads to increased horizontal gene transfer and it would be of great interest to do in vivo investigation of horizontal gene transfer during treatment with ciprofloxacin.

## **CgA as prototype for development of quinolone resistance and multiresistance**

CgA were prevalent among *E. coli* from UTI in Norway in 2001. All the isolates were sensitive to quinolones and not multiresistant. In 2003 and 2005 CgA were only found among quinolone resistant isolates and showed increasing resistance to other antibiotics. This gives us a unique opportunity to compare these two different groups of CgA to investigate resistance mechanisms, plasmids and transfer mechanisms. Comparing sequences of genome and plasmids from isolates belonging to the two CgA groups to look for the differences would most likely be possible when belonging to the same clonal group.

## References

1. Drlica K, Zhao X: **DNA gyrase, topoisomerase IV, and the 4-quinolones.** *Microbiology and molecular biology reviews : MMBR* 1997, **61**(3):377-392.
2. Komp Lindgren P, Karlsson A, Hughes D: **Mutation rate and evolution of fluoroquinolone resistance in Escherichia coli isolates from patients with urinary tract infections.** *Antimicrob Agents Chemother* 2003, **47**(10):3222-3232.
3. Rodriguez-Martinez JM, Cano ME, Velasco C, Martinez-Martinez L, Pascual A: **Plasmid-mediated quinolone resistance: an update.** *Journal of infection and chemotherapy : official journal of the Japan Society of Chemotherapy* 2011, **17**(2):149-182.
4. Piddock LJ: **Mechanisms of fluoroquinolone resistance: an update 1994-1998.** *Drugs* 1999, **58 Suppl 2**:11-18.
5. **European Centre for Disease Prevention and Control (ECDC) 2005 - 2014** [<http://www.ecdc.europa.eu/en/activities/surveillance/Pages/index.aspx>]
6. Foxman B: **Epidemiology of urinary tract infections: incidence, morbidity, and economic costs.** *The American journal of medicine* 2002, **113 Suppl 1A**:5S-13S.
7. Foxman B, Gillespie B, Koopman J, Zhang L, Palin K, Tallman P, Marsh JV, Spear S, Sobel JD, Marty MJ *et al*: **Risk factors for second urinary tract infection among college women.** *American journal of epidemiology* 2000, **151**(12):1194-1205.
8. Carlson KJ, Mulley AG: **Management of acute dysuria. A decision-analysis model of alternative strategies.** *Annals of internal medicine* 1985, **102**(2):244-249.
9. Kunin CM: **Urinary tract infections in females.** *Clinical infectious diseases : an official publication of the Infectious Diseases Society of America* 1994, **18**(1):1-10; quiz 11-12.
10. Engel JD, Schaeffer AJ: **Evaluation of and antimicrobial therapy for recurrent urinary tract infections in women.** *The Urologic clinics of North America* 1998, **25**(4):685-701, x.
11. Grude N, Tveten Y, Jenkins A, Kristiansen BE: **Uncomplicated urinary tract infections. Bacterial findings and efficacy of empirical antibacterial treatment.** *Scandinavian journal of primary health care* 2005, **23**(2):115-119.
12. **Arbeidsgruppen for antibiotikaspørsmål** [<http://www.unn.no/afa/category10274.html>]
13. Guyot A, Barrett SP, Threlfall EJ, Hampton MD, Cheasty T: **Molecular epidemiology of multi-resistant Escherichia coli.** *The Journal of hospital infection* 1999, **43**(1):39-48.
14. Johnson JR, Kuskowski MA, Menard M, Gajewski A, Xercavins M, Garau J: **Similarity between human and chicken Escherichia coli isolates in relation to ciprofloxacin resistance status.** *The Journal of infectious diseases* 2006, **194**(1):71-78.
15. **Norm-Vetrappporten** [<http://www.unn.no/rappporter/category10270.html>]
16. Sundsfjord A SM: **Antibiotika til dyr og resistens hos bakterier fra dyr – betydning for menneskers helse.** *Tidsskrift for den norske legeforening* 2008, **61**.
17. Alekshun MN, Levy SB: **Regulation of chromosomally mediated multiple antibiotic resistance: the mar regulon.** *Antimicrob Agents Chemother* 1997, **41**(10):2067-2075.
18. Alekshun MN, Levy SB: **The mar regulon: multiple resistance to antibiotics and other toxic chemicals.** *Trends in microbiology* 1999, **7**(10):410-413.
19. Orlen H, Hughes D: **Weak mutators can drive the evolution of fluoroquinolone resistance in Escherichia coli.** *Antimicrob Agents Chemother* 2006, **50**(10):3454-3456.
20. Marcusson LL, Frimodt-Moller N, Hughes D: **Interplay in the selection of fluoroquinolone resistance and bacterial fitness.** *PLoS pathogens* 2009, **5**(8):e1000541.
21. Giuliadori AM, Gualerzi CO, Soto S, Vila J, Tavio MM: **Review on bacterial stress topics.** *Annals of the New York Academy of Sciences* 2007, **1113**:95-104.
22. Lopez E, Elez M, Matic I, Blazquez J: **Antibiotic-mediated recombination: ciprofloxacin stimulates SOS-independent recombination of divergent sequences in Escherichia coli.** *Molecular microbiology* 2007, **64**(1):83-93.

23. Soto SM, Jimenez de Anta MT, Vila J: **Quinolones induce partial or total loss of pathogenicity islands in uropathogenic Escherichia coli by SOS-dependent or -independent pathways, respectively.** *Antimicrob Agents Chemother* 2006, **50**(2):649-653.
24. Martinez-Martinez L, Pascual A, Jacoby GA: **Quinolone resistance from a transferable plasmid.** *Lancet* 1998, **351**(9105):797-799.
25. Touchon M, Hoede C, Tenaillon O, Barbe V, Baeriswyl S, Bidet P, Bingen E, Bonacorsi S, Bouchier C, Bouvet O *et al*: **Organised genome dynamics in the Escherichia coli species results in highly diverse adaptive paths.** *PLoS genetics* 2009, **5**(1):e1000344.
26. Hartl DL, Dykhuizen DE: **The population genetics of Escherichia coli.** *Annual review of genetics* 1984, **18**:31-68.
27. Finegold SM SV, Mathisen GE: **Normal indigenous intestinal flora:** Acad. Press; 1983.
28. Bettelheim KA, Breadon A, Faiers MC, O'Farrell SM, Shooter RA: **The origin of O serotypes of Escherichia coli in babies after normal delivery.** *The Journal of hygiene* 1974, **72**(1):67-70.
29. Fryklund B, Tullus K, Berglund B, Burman LG: **Importance of the environment and the faecal flora of infants, nursing staff and parents as sources of gram-negative bacteria colonizing newborns in three neonatal wards.** *Infection* 1992, **20**(5):253-257.
30. Sears HJ, Brownlee I: **Further observations on the persistence of individual strains of Escherichia coli in the intestinal tract of man.** *Journal of bacteriology* 1952, **63**(1):47-57.
31. Sears HJ, Brownlee I, Uchiyama JK: **Persistence of individual strains of Escherichia coli in the intestinal tract of man.** *Journal of bacteriology* 1950, **59**(2):293-301.
32. Sears HJ, Janes H, Saloum R, Brownlee I, Lamoreaux LF: **Persistence of individual strains of Escherichia coli in man and dog under varying conditions.** *Journal of bacteriology* 1956, **71**(3):370-372.
33. Smith JM, Smith NH, O'Rourke M, Spratt BG: **How clonal are bacteria?** *Proceedings of the National Academy of Sciences of the United States of America* 1993, **90**(10):4384-4388.
34. Gouillet P, Picard B: **Comparative electrophoretic polymorphism of esterases and other enzymes in Escherichia coli.** *Journal of general microbiology* 1989, **135**(1):135-143.
35. Selander RK, Caugant DA, Ochman H, Musser JM, Gilmour MN, Whittam TS: **Methods of multilocus enzyme electrophoresis for bacterial population genetics and systematics.** *Applied and environmental microbiology* 1986, **51**(5):873-884.
36. Herzer PJ, Inouye S, Inouye M, Whittam TS: **Phylogenetic distribution of branched RNA-linked multicopy single-stranded DNA among natural isolates of Escherichia coli.** *Journal of bacteriology* 1990, **172**(11):6175-6181.
37. Selander R. K. CDA, Whittam T. S. : **Genetic structure and variation in natural populations of Escherichia coli:** American Society for Microbiology; 1987.
38. Jaureguy F, Landraud L, Passet V, Diancourt L, Frapy E, Guigon G, Carbonnelle E, Lortholary O, Clermont O, Denamur E *et al*: **Phylogenetic and genomic diversity of human bacteremic Escherichia coli strains.** *BMC genomics* 2008, **9**:560.
39. Tenaillon O, Skurnik D, Picard B, Denamur E: **The population genetics of commensal Escherichia coli.** *Nature reviews Microbiology* 2010, **8**(3):207-217.
40. Lescat M, Hoede C, Clermont O, Garry L, Darlu P, Tuffery P, Denamur E, Picard B: **aes, the gene encoding the esterase B in Escherichia coli, is a powerful phylogenetic marker of the species.** *BMC microbiology* 2009, **9**:273.
41. Clermont O, Bonacorsi S, Bingen E: **Rapid and simple determination of the Escherichia coli phylogenetic group.** *Applied and environmental microbiology* 2000, **66**(10):4555-4558.
42. Cagnacci S, Gualco L, Debbia E, Schito GC, Marchese A: **European emergence of ciprofloxacin-resistant Escherichia coli clonal groups O25:H4-ST 131 and O15:K52:H1 causing community-acquired uncomplicated cystitis.** *J Clin Microbiol* 2008, **46**(8):2605-2612.
43. Johnson JR, Menard Me Fau - Lauderdale T-L, Lauderdale TI Fau - Kosmidis C, Kosmidis C Fau - Gordon D, Gordon D Fau - Collignon P, Collignon P Fau - Maslow JN, Maslow Jn Fau - Andrasevic AT, Andrasevic At Fau - Kuskowski MA, Kuskowski MA: **Global distribution and**



- epidemiologic associations of Escherichia coli clonal group A, 1998-2007.** 2011(1080-6059 (Electronic)).
44. Johnson JR, Murray AC, Kuskowski MA, Schubert S, Prere MF, Picard B, Colodner R, Raz R, Trans-Global Initiative for Antimicrobial Resistance Initiative I: **Distribution and characteristics of Escherichia coli clonal group A.** *Emerging infectious diseases* 2005, **11**(1):141-145.
  45. Manges AR, Johnson JR, Foxman B, O'Bryan TT, Fullerton KE, Riley LW: **Widespread distribution of urinary tract infections caused by a multidrug-resistant Escherichia coli clonal group.** *The New England journal of medicine* 2001, **345**(14):1007-1013.
  46. Johnson JR, Stell AL, O'Bryan TT, Kuskowski M, Nowicki B, Johnson C, Maslow JN, Kaul A, Kavle J, Prats G: **Global molecular epidemiology of the O15:K52:H1 extraintestinal pathogenic Escherichia coli clonal group: evidence of distribution beyond Europe.** *J Clin Microbiol* 2002, **40**(6):1913-1923.
  47. Johnson JR, Menard M, Johnston B, Kuskowski MA, Nichol K, Zhanel GG: **Epidemic Clonal Groups of Escherichia coli as a Cause of Antimicrobial-Resistant Urinary Tract Infections in Canada, 2002 to 2004.** *Antimicrobial Agents and Chemotherapy* 2009, **53**(7):2733-2739.
  48. Olesen B, Scheutz F, Menard M, Skov MN, Kolmos HJ, Kuskowski MA, Johnson JR: **Three-Decade Epidemiological Analysis of Escherichia coli O15:K52:H1.** *Journal of Clinical Microbiology* 2009, **47**(6):1857-1862.
  49. Johnson JR, Manges AR, O'Bryan TT, Riley LW: **A disseminated multidrug-resistant clonal group of uropathogenic Escherichia coli in pyelonephritis.** *Lancet* 2002, **359**(9325):2249-2251.
  50. Manges AR, Dietrich PS, Riley LW: **Multidrug-resistant Escherichia coli clonal groups causing community-acquired pyelonephritis.** *Clinical infectious diseases : an official publication of the Infectious Diseases Society of America* 2004, **38**(3):329-334.
  51. Johnson JR, Owens KL, Clabots CR, Weissman SJ, Cannon SB: **Phylogenetic relationships among clonal groups of extraintestinal pathogenic Escherichia coli as assessed by multi-locus sequence analysis.** *Microbes and infection / Institut Pasteur* 2006, **8**(7):1702-1713.
  52. Tartof SY, Solberg OD, Manges AR, Riley LW: **Analysis of a uropathogenic Escherichia coli clonal group by multilocus sequence typing.** *J Clin Microbiol* 2005, **43**(12):5860-5864.
  53. Stamm WE: **An epidemic of urinary tract infections?** *The New England journal of medicine* 2001, **345**(14):1055-1057.
  54. Clermont O, Lavollay M, Vimont S, Deschamps C, Forestier C, Branger C, Denamur E, Arlet G: **The CTX-M-15-producing Escherichia coli diffusing clone belongs to a highly virulent B2 phylogenetic subgroup.** *The Journal of antimicrobial chemotherapy* 2008, **61**(5):1024-1028.
  55. Coque TM, Novais A, Carattoli A, Poirel L, Pitout J, Peixe L, Baquero F, Canton R, Nordmann P: **Dissemination of clonally related Escherichia coli strains expressing extended-spectrum beta-lactamase CTX-M-15.** *Emerging infectious diseases* 2008, **14**(2):195-200.
  56. Nicolas-Chanoine MH, Blanco J, Leflon-Guibout V, Demarty R, Alonso MP, Canica MM, Park YJ, Lavigne JP, Pitout J, Johnson JR: **Intercontinental emergence of Escherichia coli clone O25:H4-ST131 producing CTX-M-15.** *The Journal of antimicrobial chemotherapy* 2008, **61**(2):273-281.
  57. Rogers BA, Sidjabat HE, Paterson DL: **Escherichia coli O25b-ST131: a pandemic, multiresistant, community-associated strain.** *The Journal of antimicrobial chemotherapy* 2011, **66**(1):1-14.
  58. Kauffmann F: **The serology of the coli group.** *Journal of immunology* 1947, **57**(1):71-100.
  59. Orskov I, Orskov F, Rowe B: **Six new E. coli O groups: O165, O166, O167, O168, O169 and O170.** *Acta pathologica, microbiologica, et immunologica Scandinavica Section B, Microbiology* 1984, **92**(4):189-193.
  60. Rasko DA, Webster DR, Sahl JW, Bashir A, Boisen N, Scheutz F, Paxinos EE, Sebra R, Chin CS, Iliopoulos D *et al*: **Origins of the E. coli strain causing an outbreak of hemolytic-uremic syndrome in Germany.** *The New England journal of medicine* 2011, **365**(8):709-717.

61. Orskov F, Orskov I: **Escherichia coli serotyping and disease in man and animals.** *Canadian journal of microbiology* 1992, **38**(7):699-704.
62. **Medical microbiology. Chapter 2, Structure** [<http://www.ncbi.nlm.nih.gov/books/NBK8477/>]
63. Clermont O, Johnson JR, Menard M, Denamur E: **Determination of Escherichia coli O types by allele-specific polymerase chain reaction: application to the O types involved in human septicemia.** *Diagnostic microbiology and infectious disease* 2007, **57**(2):129-136.
64. Grimont F, Grimont PA: **Ribosomal ribonucleic acid gene restriction patterns as potential taxonomic tools.** *Annales de l'Institut Pasteur Microbiology* 1986, **137B**(2):165-175.
65. Stull TL, LiPuma JJ, Edlind TD: **A broad-spectrum probe for molecular epidemiology of bacteria: ribosomal RNA.** *The Journal of infectious diseases* 1988, **157**(2):280-286.
66. Clermont O, Cordevant C, Bonacorsi S, Marecat A, Lange M, Bingen E: **Automated ribotyping provides rapid phylogenetic subgroup affiliation of clinical extraintestinal pathogenic Escherichia coli strains.** *J Clin Microbiol* 2001, **39**(12):4549-4553.
67. Maiden MCJ, van Rensburg MJJ, Bray JE, Earle SG, Ford SA, Jolley KA, McCarthy ND: **MLST revisited: the gene-by-gene approach to bacterial genomics.** *Nat Rev Micro* 2013, **11**(10):728-736.
68. Maiden MC, Bygraves JA, Feil E, Morelli G, Russell JE, Urwin R, Zhang Q, Zhou J, Zurth K, Caugant DA *et al*: **Multilocus sequence typing: a portable approach to the identification of clones within populations of pathogenic microorganisms.** *Proceedings of the National Academy of Sciences of the United States of America* 1998, **95**(6):3140-3145.
69. Gordon DM, Clermont O, Tolley H, Denamur E: **Assigning Escherichia coli strains to phylogenetic groups: multi-locus sequence typing versus the PCR triplex method.** *Environmental microbiology* 2008, **10**(10):2484-2496.
70. Smith CL, Cantor CR: **Approaches to physical mapping of the human genome.** *Cold Spring Harbor symposia on quantitative biology* 1986, **51 Pt 1**:115-122.
71. Smith CL, Cantor CR: **Purification, specific fragmentation, and separation of large DNA molecules.** *Methods in enzymology* 1987, **155**:449-467.
72. Smith CL, Econome JG, Schutt A, Klco S, Cantor CR: **A physical map of the Escherichia coli K12 genome.** *Science* 1987, **236**(4807):1448-1453.
73. Tenover FC, Arbeit RD, Goering RV, Mickelsen PA, Murray BE, Persing DH, Swaminathan B: **Interpreting chromosomal DNA restriction patterns produced by pulsed-field gel electrophoresis: criteria for bacterial strain typing.** *J Clin Microbiol* 1995, **33**(9):2233-2239.
74. Vos P, Hogers R, Bleeker M, Reijans M, van de Lee T, Hornes M, Frijters A, Pot J, Peleman J, Kuiper M *et al*: **AFLP: a new technique for DNA fingerprinting.** *Nucleic acids research* 1995, **23**(21):4407-4414.
75. Nakamura Y, Itoh T, Matsuda H, Gojobori T: **Biased biological functions of horizontally transferred genes in prokaryotic genomes.** *Nature genetics* 2004, **36**(7):760-766.
76. Thomas CM, Nielsen KM: **Mechanisms of, and barriers to, horizontal gene transfer between bacteria.** *Nature reviews Microbiology* 2005, **3**(9):711-721.
77. Avery OT, MacLeod CM, McCarty M: **Studies on the chemical nature of the substance inducing transformation of pneumococcal types. Induction of transformation by a desoxyribonucleic acid fraction isolated from Pneumococcus type III. 1944.** *Molecular medicine* 1995, **1**(4):344-365.
78. Lederberg J, Tatum EL: **Gene recombination in Escherichia coli.** *Nature* 1946, **158**(4016):558.
79. Tatum EL, Lederberg J: **Gene Recombination in the Bacterium Escherichia coli.** *Journal of bacteriology* 1947, **53**(6):673-684.
80. Zinder ND, Lederberg J: **Genetic exchange in Salmonella.** *Journal of bacteriology* 1952, **64**(5):679-699.
81. John M. Martinko DAS, Michael T. Madigan: **Brock Biology of Microorganisms**, 13. edn: Pearson Education; 2012.
82. Novick RP: **Plasmid incompatibility.** *Microbiological reviews* 1987, **51**(4):381-395.

83. Smillie C, Garcillan-Barcia MP, Francia MV, Rocha EP, de la Cruz F: **Mobility of plasmids.** *Microbiology and molecular biology reviews : MMBR* 2010, **74**(3):434-452.
84. Salyers AA, Shoemaker NB, Stevens AM, Li LY: **Conjugative transposons: an unusual and diverse set of integrated gene transfer elements.** *Microbiological reviews* 1995, **59**(4):579-590.
85. Collis CM, Hall RM: **Expression of antibiotic resistance genes in the integrated cassettes of integrons.** *Antimicrob Agents Chemother* 1995, **39**(1):155-162.
86. Bennett PM: **Genome plasticity: insertion sequence elements, transposons and integrons, and DNA rearrangement.** *Methods in molecular biology* 2004, **266**:71-113.
87. Hall RM, Collis CM: **Mobile gene cassettes and integrons: capture and spread of genes by site-specific recombination.** *Molecular microbiology* 1995, **15**(4):593-600.
88. Toleman MA, Bennett PM, Walsh TR: **ISCR elements: novel gene-capturing systems of the 21st century?** *Microbiology and molecular biology reviews : MMBR* 2006, **70**(2):296-316.
89. Toleman MA, Bennett PM, Walsh TR: **Common regions e.g. orf513 and antibiotic resistance: IS91-like elements evolving complex class 1 integrons.** *The Journal of antimicrobial chemotherapy* 2006, **58**(1):1-6.
90. Call DR, Singer RS, Meng D, Broschat SL, Orfe LH, Anderson JM, Herndon DR, Kappmeyer LS, Daniels JB, Besser TE: **bla<sub>CMY-2</sub>-positive IncA/C plasmids from Escherichia coli and Salmonella enterica are a distinct component of a larger lineage of plasmids.** *Antimicrob Agents Chemother* 2010, **54**(2):590-596.
91. Toleman MA, Walsh TR: **ISCR elements are key players in IncA/C plasmid evolution.** *Antimicrob Agents Chemother* 2010, **54**(8):3534; author reply 3534.
92. Gal-Mor O, Finlay BB: **Pathogenicity islands: a molecular toolbox for bacterial virulence.** *Cellular microbiology* 2006, **8**(11):1707-1719.
93. Schmidt H, Hensel M: **Pathogenicity islands in bacterial pathogenesis.** *Clinical microbiology reviews* 2004, **17**(1):14-56.
94. Andrews JM: **Determination of minimum inhibitory concentrations.** *The Journal of antimicrobial chemotherapy* 2001, **48 Suppl 1**:5-16.
95. **EUCAST**  
[http://www.eucast.org/antimicrobial\\_susceptibility\\_testing/previous\\_versions\\_of\\_tables/](http://www.eucast.org/antimicrobial_susceptibility_testing/previous_versions_of_tables/)
96. Davies J, Davies D: **Origins and evolution of antibiotic resistance.** *Microbiology and molecular biology reviews : MMBR* 2010, **74**(3):417-433.
97. Kristiansen BE: **Patogenic bacteria in the urinary tract. Incidence and resistance behaviour.** *tidsskrift norske legeförening* 1983, **24**:1684-1686.
98. Hooton TM, Stamm WE: **Diagnosis and treatment of uncomplicated urinary tract infection.** *Infectious disease clinics of North America* 1997, **11**(3):551-581.
99. Strand L, Jenkins A, Henriksen IH, Allum AG, Grude N, Kristiansen BE: **High levels of multiresistance in quinolone resistant urinary tract isolates of Escherichia coli from Norway; a non clonal phenomenon?** *BMC research notes* 2014, **7**:376.
100. Kohanski MA, Dwyer DJ, Collins JJ: **How antibiotics kill bacteria: from targets to networks.** *Nat Rev Micro* 2010, **8**(6):423-435.
101. Drlica K, Malik M, Kerns RJ, Zhao X: **Quinolone-mediated bacterial death.** *Antimicrob Agents Chemother* 2008, **52**(2):385-392.
102. Hooper DC: **Emerging mechanisms of fluoroquinolone resistance.** *Emerging infectious diseases* 2001, **7**(2):337-341.
103. Jacoby GA: **Mechanisms of resistance to quinolones.** *Clinical infectious diseases : an official publication of the Infectious Diseases Society of America* 2005, **41 Suppl 2**:S120-126.
104. Strahilevitz J, Jacoby GA, Hooper DC, Robicsek A: **Plasmid-mediated quinolone resistance: a multifaceted threat.** *Clinical microbiology reviews* 2009, **22**(4):664-689.
105. Robicsek A, Strahilevitz J, Jacoby GA, Macielag M, Abbanat D, Park CH, Bush K, Hooper DC: **Fluoroquinolone-modifying enzyme: a new adaptation of a common aminoglycoside acetyltransferase.** *Nature medicine* 2006, **12**(1):83-88.

106. Perichon B, Courvalin P, Galimand M: **Transferable resistance to aminoglycosides by methylation of G1405 in 16S rRNA and to hydrophilic fluoroquinolones by QepA-mediated efflux in Escherichia coli.** *Antimicrob Agents Chemother* 2007, **51**(7):2464-2469.
107. Yamane K, Wachino J, Suzuki S, Kimura K, Shibata N, Kato H, Shibayama K, Konda T, Arakawa Y: **New plasmid-mediated fluoroquinolone efflux pump, QepA, found in an Escherichia coli clinical isolate.** *Antimicrob Agents Chemother* 2007, **51**(9):3354-3360.
108. Zhao X, Drlica K: **Restricting the selection of antibiotic-resistant mutants: a general strategy derived from fluoroquinolone studies.** *Clinical infectious diseases : an official publication of the Infectious Diseases Society of America* 2001, **33 Suppl 3**:S147-156.
109. Karlowsky JA, Hoban DJ, Decorby MR, Laing NM, Zhanel GG: **Fluoroquinolone-resistant urinary isolates of Escherichia coli from outpatients are frequently multidrug resistant: results from the North American Urinary Tract Infection Collaborative Alliance-Quinolone Resistance study.** *Antimicrob Agents Chemother* 2006, **50**(6):2251-2254.
110. Giufre M, Graziani C, Accogli M, Luzzi I, Busani L, Cerquetti M, Escherichia coli Study G: **Escherichia coli of human and avian origin: detection of clonal groups associated with fluoroquinolone and multidrug resistance in Italy.** *The Journal of antimicrobial chemotherapy* 2012, **67**(4):860-867.
111. Platell JL, Cobbold RN, Johnson JR, Trott DJ: **Clonal group distribution of fluoroquinolone-resistant Escherichia coli among humans and companion animals in Australia.** *The Journal of antimicrobial chemotherapy* 2010, **65**(9):1936-1938.
112. Radman M: **SOS repair hypothesis: phenomenology of an inducible DNA repair which is accompanied by mutagenesis.** *Basic life sciences* 1975, **5A**:355-367.
113. Michel B: **After 30 years of study, the bacterial SOS response still surprises us.** *PLoS biology* 2005, **3**(7):e255.
114. Beaber JW, Hochhut B, Waldor MK: **SOS response promotes horizontal dissemination of antibiotic resistance genes.** *Nature* 2004, **427**(6969):72-74.
115. Guerin E, Cambray G, Sanchez-Alberola N, Campoy S, Erill I, Da Re S, Gonzalez-Zorn B, Barbe J, Ploy MC, Mazel D: **The SOS response controls integron recombination.** *Science* 2009, **324**(5930):1034.
116. Cirz RT, Chin JK, Andes DR, de Crecy-Lagard V, Craig WA, Romesberg FE: **Inhibition of mutation and combating the evolution of antibiotic resistance.** *PLoS biology* 2005, **3**(6):e176.
117. Da Re S, Garnier F, Guerin E, Campoy S, Denis F, Ploy MC: **The SOS response promotes qnrB quinolone-resistance determinant expression.** *EMBO reports* 2009, **10**(8):929-933.
118. Croxen MA, Finlay BB: **Molecular mechanisms of Escherichia coli pathogenicity.** *Nature reviews Microbiology* 2010, **8**(1):26-38.
119. Johnson JR: **Virulence factors in Escherichia coli urinary tract infection.** *Clinical microbiology reviews* 1991, **4**(1):80-128.
120. Agarwal J, Srivastava S, Singh M: **Pathogenomics of uropathogenic Escherichia coli.** *Indian journal of medical microbiology* 2012, **30**(2):141-149.
121. Egeberg NN: **"Kinolonresistente E. coli i urinveisolater; Resistensmekanismer".** *MSc thesis, Telemark college* 2009.
122. Langerud BK: **"Overførbar antibiotikaresistens hos Escherichia coli".** *MSc thesis, Telemark college* 2008.
123. Mykland HK: **"Fluorokinolonresistente E. coli i Telemark; Genetisk typing og resistensforhold".** *MSc thesis, Telemark college* 2006.
124. N. G: **Urinary tract infections with emphasize on bacterial etiology, sensitivity, virulence and clonal distribution.** University of Tromsø; 2006.
125. Jacoby GA, Chow N, Waites KB: **Prevalence of plasmid-mediated quinolone resistance.** *Antimicrob Agents Chemother* 2003, **47**(2):559-562.

126. Poirel L, Cattoir V, Soares A, Soussy CJ, Nordmann P: **Novel Ambler class A beta-lactamase LAP-1 and its association with the plasmid-mediated quinolone resistance determinant QnrS1.** *Antimicrob Agents Chemother* 2007, **51**(2):631-637.
127. Johnson JR, Owens K, Manges AR, Riley LW: **Rapid and specific detection of Escherichia coli clonal group A by gene-specific PCR.** *J Clin Microbiol* 2004, **42**(6):2618-2622.
128. Nowrouzian F, Adlerberth I, Wold AE: **P fimbriae, capsule and aerobactin characterize colonic resident Escherichia coli.** *Epidemiology and infection* 2001, **126**(1):11-18.
129. Weigel LM, Steward CD, Tenover FC: **gyrA mutations associated with fluoroquinolone resistance in eight species of Enterobacteriaceae.** *Antimicrob Agents Chemother* 1998, **42**(10):2661-2667.
130. Park CH, Robicsek A, Jacoby GA, Sahm D, Hooper DC: **Prevalence in the United States of aac(6')-Ib-cr encoding a ciprofloxacin-modifying enzyme.** *Antimicrob Agents Chemother* 2006, **50**(11):3953-3955.
131. Robicsek A, Strahilevitz J, Sahm DF, Jacoby GA, Hooper DC: **qnr prevalence in ceftazidime-resistant Enterobacteriaceae isolates from the United States.** *Antimicrob Agents Chemother* 2006, **50**(8):2872-2874.
132. Asako H, Nakajima H, Kobayashi K, Kobayashi M, Aono R: **Organic solvent tolerance and antibiotic resistance increased by overexpression of marA in Escherichia coli.** *Applied and environmental microbiology* 1997, **63**(4):1428-1433.
133. Grude N, Potaturkina-Nesterova NI, Jenkins A, Strand L, Nowrouzian FL, Nyhus J, Kristiansen BE: **A comparison of phylogenetic group, virulence factors and antibiotic resistance in Russian and Norwegian isolates of Escherichia coli from urinary tract infection.** *Clinical microbiology and infection : the official publication of the European Society of Clinical Microbiology and Infectious Diseases* 2007, **13**(2):208-211.
134. Strand L, Jenkins A, Grude N, Allum AG, Mykland HC, Nowrouzian FL, Kristiansen BE: **Emergence of fluoroquinolone-resistant clonal group A: clonal analysis of Norwegian and Russian E. coli isolates.** *APMIS : acta pathologica, microbiologica, et immunologica Scandinavica* 2010, **118**(8):571-577.
135. Strand Linda JA, Narmoe Nina, Langerud Kiland Beate, Allum Anne-Gry, Grude Nils, Kristiansen Bjørn Erik: **Resistance Mechanisms in multiresistant fluoroquinolone resistant Escherichia coli at an early stage of the emergence of ciprofloxacin resistance in Norway.** . *Manuscript ready for submission* 2014.
136. Grude N, Strand L, Mykland H, Nowrouzian FL, Nyhus J, Jenkins A, Kristiansen BE: **Fluoroquinolone-resistant uropathogenic Escherichia coli in Norway: evidence of clonal spread.** *Clinical microbiology and infection : the official publication of the European Society of Clinical Microbiology and Infectious Diseases* 2008, **14**(5):498-500.
137. Litlekare I BHS, Rønning M: **Antibiotic use in Norway.** *Tidsskr Nor Legeforen* 2008, **20** (128):5.
138. Hopkins S, Coleman C, Kelleher M, Keating S, Clarke S, O'Connell B, Mulcahy F, Bergin C: **Increasing resistance to ciprofloxacin among isolates of Neisseria gonorrhoea in Dublin.** *Irish medical journal* 2005, **98**(7):208-209.
139. Hakanen A, Kotilainen P, Jalava J, Siitonen A, Huovinen P: **Detection of decreased fluoroquinolone susceptibility in Salmonellas and validation of nalidixic acid screening test.** *J Clin Microbiol* 1999, **37**(11):3572-3577.
140. Johnson JR, van der Schee C, Kuskowski MA, Goessens W, van Belkum A: **Phylogenetic background and virulence profiles of fluoroquinolone-resistant clinical Escherichia coli isolates from the Netherlands.** *The Journal of infectious diseases* 2002, **186**(12):1852-1856.
141. Johnson JR, Kuskowski MA, O'Bryan T T, Colodner R, Raz R: **Virulence genotype and phylogenetic origin in relation to antibiotic resistance profile among Escherichia coli urine sample isolates from Israeli women with acute uncomplicated cystitis.** *Antimicrob Agents Chemother* 2005, **49**(1):26-31.

142. Moreno E, Prats G, Sabate M, Perez T, Johnson JR, Andreu A: **Quinolone, fluoroquinolone and trimethoprim/sulfamethoxazole resistance in relation to virulence determinants and phylogenetic background among uropathogenic Escherichia coli.** *The Journal of antimicrobial chemotherapy* 2006, **57**(2):204-211.
143. Chaudhuri RR, Henderson IR: **The evolution of the Escherichia coli phylogeny.** *Infection, genetics and evolution : journal of molecular epidemiology and evolutionary genetics in infectious diseases* 2012, **12**(2):214-226.
144. Bouchet V, Huot H, Goldstein R: **Molecular genetic basis of ribotyping.** *Clinical microbiology reviews* 2008, **21**(2):262-273, table of contents.
145. Zhao S, Mitchell SE, Meng J, Kresovich S, Doyle MP, Dean RE, Casa AM, Weller JW: **Genomic typing of Escherichia coli O157:H7 by semi-automated fluorescent AFLP analysis.** *Microbes and infection / Institut Pasteur* 2000, **2**(2):107-113.
146. Silbert S, Boyken L, Hollis RJ, Pfaller MA: **Improving typeability of multiple bacterial species using pulsed-field gel electrophoresis and thiourea.** *Diagnostic microbiology and infectious disease* 2003, **47**(4):619-621.
147. Hollis RJ, Bruce JL, Fritschel SJ, Pfaller MA: **Comparative evaluation of an automated ribotyping instrument versus pulsed-field gel electrophoresis for epidemiological investigation of clinical isolates of bacteria.** *Diagnostic microbiology and infectious disease* 1999, **34**(4):263-268.
148. Ray T, Weaden J, Dyson P: **Tris-dependent site-specific cleavage of Streptomyces lividans DNA.** *FEMS microbiology letters* 1992, **75**(2-3):247-252.
149. Martinez JL: **Antibiotics and antibiotic resistance genes in natural environments.** *Science* 2008, **321**(5887):365-367.
150. Alekshun MN, Levy SB: **Commensals upon us.** *Biochemical pharmacology* 2006, **71**(7):893-900.
151. Bonnie M. Marshall DJO, and Stuart B. Levy: **Commensals: Underappreciated Reservoir of Antibiotic Resistance.** *Microbe* 2009, **4**(5):8.
152. Boczek LA, Rice EW, Johnston B, Johnson JR: **Occurrence of antibiotic-resistant uropathogenic Escherichia coli clonal group A in wastewater effluents.** *Applied and environmental microbiology* 2007, **73**(13):4180-4184.
153. Everett MJ, Jin YF, Ricci V, Piddock LJ: **Contributions of individual mechanisms to fluoroquinolone resistance in 36 Escherichia coli strains isolated from humans and animals.** *Antimicrob Agents Chemother* 1996, **40**(10):2380-2386.
154. Yoshida H, Kojima T, Yamagishi J, Nakamura S: **Quinolone-resistant mutations of the gyrA gene of Escherichia coli.** *Molecular & general genetics : MGG* 1988, **211**(1):1-7.
155. Karah N, Poirel L, Bengtsson S, Sundqvist M, Kahlmeter G, Nordmann P, Sundsfjord A, Samuelsen O, Norwegian Study Group on P: **Plasmid-mediated quinolone resistance determinants qnr and aac(6')-Ib-cr in Escherichia coli and Klebsiella spp. from Norway and Sweden.** *Diagnostic microbiology and infectious disease* 2010, **66**(4):425-431.
156. Yang T, Zeng Z, Rao L, Chen X, He D, Lv L, Wang J, Zeng L, Feng M, Liu JH: **The association between occurrence of plasmid-mediated quinolone resistance and ciprofloxacin resistance in Escherichia coli isolates of different origins.** *Veterinary microbiology* 2014, **170**(1-2):89-96.
157. Pasom W, Chanawong A, Lulitanond A, Wilailuckana C, Kenprom S, Puang-Ngern P: **Plasmid-mediated quinolone resistance genes, aac(6')-Ib-cr, qnrS, qnrB, and qnrA, in urinary isolates of Escherichia coli and Klebsiella pneumoniae at a teaching hospital, Thailand.** *Japanese journal of infectious diseases* 2013, **66**(5):428-432.
158. Ruiz del Castillo B, Vinue L, Roman EJ, Guerra B, Carattoli A, Torres C, Martinez-Martinez L: **Molecular characterization of multiresistant Escherichia coli producing or not extended-spectrum beta-lactamases.** *BMC microbiology* 2013, **13**:84.

159. Platell JL, Johnson JR, Cobbold RN, Trott DJ: **Multidrug-resistant extraintestinal pathogenic Escherichia coli of sequence type ST131 in animals and foods.** *Veterinary microbiology* 2011, **153**(1-2):99-108.
160. Ode T, Saito R, Kumita W, Sato K, Okugawa S, Moriya K, Koike K, Okamura N: **Analysis of plasmid-mediated multidrug resistance in Escherichia coli and Klebsiella oxytoca isolates from clinical specimens in Japan.** *International journal of antimicrobial agents* 2009, **34**(4):347-350.
161. Walsh TR: **Combinatorial genetic evolution of multiresistance.** *Current opinion in microbiology* 2006, **9**(5):476-482.
162. Lescat M, Calteau A, Hoede C, Barbe V, Touchon M, Rocha E, Tenaillon O, Medigue C, Johnson JR, Denamur E: **A module located at a chromosomal integration hot spot is responsible for the multidrug resistance of a reference strain from Escherichia coli clonal group A.** *Antimicrob Agents Chemother* 2009, **53**(6):2283-2288.

**Enclosed**  
Appendix 1  
Articles Paper 1-5



# Appendix 1



## Appendix 1

### Molecular typing of *Escherichia coli* by amplified length fragment polymorphism

Amplified length fragment polymorphism (AFLP) is a PCR based typing method where two different restriction enzymes are used to cut the entire genome into hundreds of fragments. Adapters are ligated to the fragments and these function as annealing sites for PCR primers. During selective amplification the forward and reverse primer anneals to each of the cut sites respectively leading to amplification of the fragments with different cut sites in each end. Primers with one or more nucleotide in extension of the 3-prime end will selectively decrease the number of fragments amplified. The fragments are separated on a polyacrylamide gel and can be detected via fluorescence marked primers using ABI PRISM 310 Genetic Analyser a capillary electrophoresis system.

This typing method was first used for plant genomes [1] but later used for molecular typing of bacteria among other *E. coli* [2-5].

The aim of this study was to validate the use of AFLP as a typing method to investigate the clonal relationship among uropathogen *E. coli* resistant to ciprofloxacin.

#### Material and method

##### Material:

35 Norwegian uropathogen *E. coli* isolates from patient with uncomplicated urinary tract infection (UTI) resistant to ciprofloxacin. The isolates were picked from blood/CLED agar and defined by Hajna [6].

##### Method:

The whole protocol from point 1-5 below was according to the AFLP™ Microbial fingerprinting protocol (Applied Biosystems 2002) [3].

1. Colonies picked from overnight cultures were inoculated in salt water to  $10^6$  cells/ml ( $OD_{600} = 0.5$ ). Genomic DNA was extracted by QIAmp DNA Mini Kit (Qiagen, Hilden, Germany).

2. Restriction digestion by 5U EcoRI (Promega Madison WL, USA) and MseI (Promega Madison WL, USA) and ligation of adaptors with 1U T4 DNA Ligase (Promega Madison WL, USA) were incubated overnight using 10 ng of genomic DNA (A260nm/A280nm between 1.7 and 2.2).
3. The restriction and ligation mix was diluted 1:20 in 1xTE-buffer before pre amplification with EcoRI and MseI primers. The pre amplified products were diluted 1:20 before selective amplification with primers EcoRI+A (adenine) and MseI+C (cytosine). The EcoRI+A primer was marked with FAM (5-carboxyfluorescein).
4. The fragments were separated on a 4% POP 4-polymer (Applied Biosystems, Warrington, USA) using 10x Thermophilic DNA polymer EDTA buffer (Promega Madison WL, USA) on ABI PRISM™ 310 Genetic analyser (Applied Biosystems, Foster City, CA). 1 µl of the amplified product was loaded on the gel together with 24 µl of formamide and 1 µl GeneScan-500 size standard. The product was denaturated at 95°C for five minutes and held on ice before loading.
5. Diagrams were produced using GeneScan Collection Software (PE Biosystems).
6. The diagrams were converted to bands by CrvConv (Bionumerics) and the fingerprint from each isolate was normalized using the bands in the internal size standard GeneScan-500.
7. The bandpatterns were analysed using UPGMA cluster analyses and Dice coefficient in GelCompar (Bionumerics).

## Results

All the isolates were typable by AFLP and the bandpatterns of each isolate contained from 50 to 85 bands in size range 35-450 base pairs. Figure 1 shows the result from GelCompar. Two isolates had identical band patterns; the band patterns of the remaining isolates were unique. The 35 isolates grouped into 29 AFLP classes at the 95% similarity level. 26 of the AFLP classes were singletons while the other three classes contained four, three and two isolates respectively.

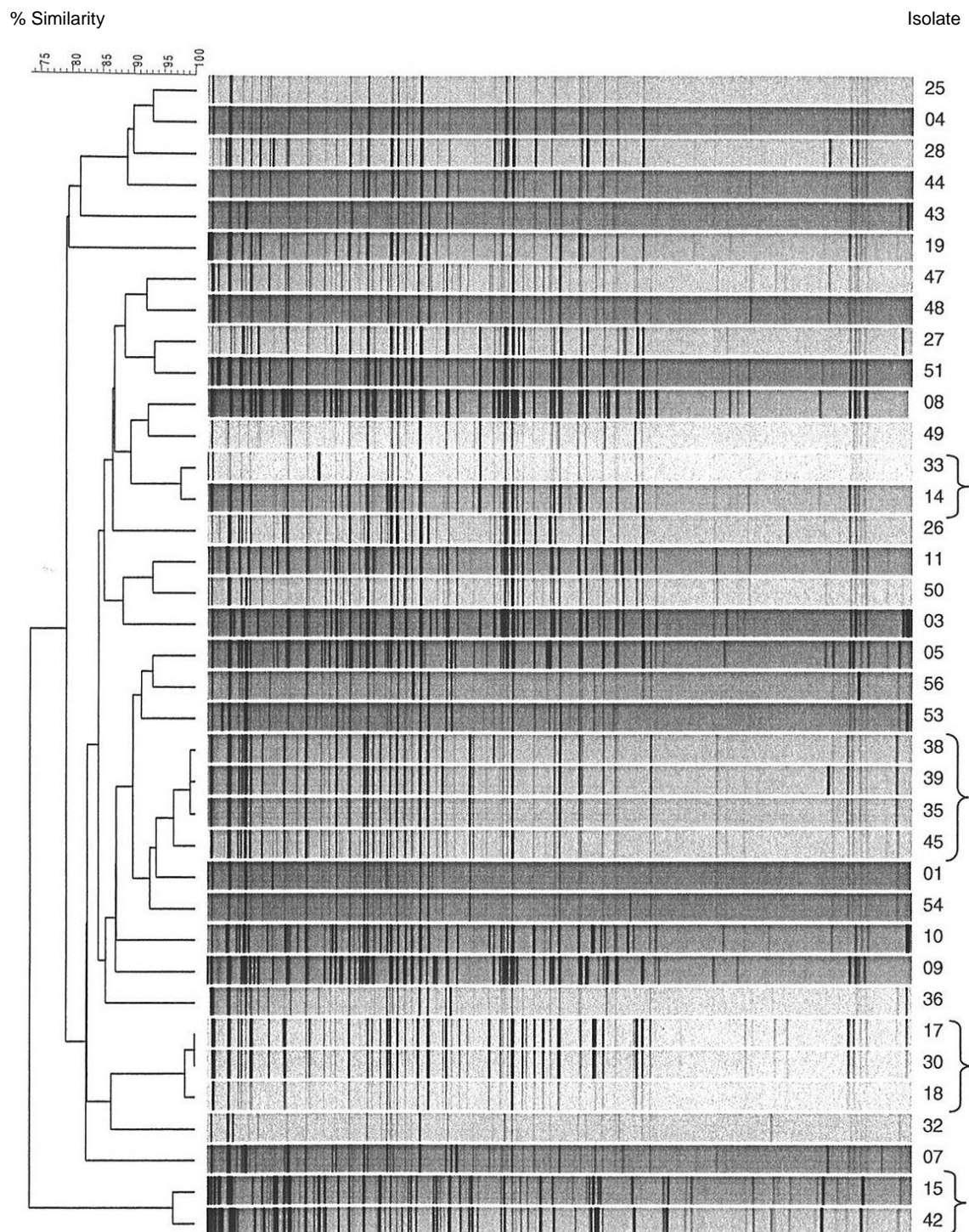

Figure 1: Dendrogram of the AFLP band profiles of 35 ciprofloxacin resistant *E. coli* using Gelcompar II analyse program (Bionumerics, Belgium). The two fingerprints representing isolate 15 and 42 (outlier group) represent *Citerobacter freundii*.

## Discussion and conclusion

AFLP is known to be a molecular typing method with high discrimination power [1-5]. We used the two restriction enzymes EcoRI (six basepair recognitions sequence) and MseI (four basepair recognition sequence) and selective PCR primers annealing to each of the restriction enzymes sites with one extra nucleotide 3-prime (EcoRI+A and MseI+C) which gave 50 to 85 fragments in size range 35-450 base pairs after separation on 4% polyacrylamide gel using ABI PRISM™ 310 Genetic analyser (Applied Biosystems, Foster City, CA). We found the method to discriminate all but two of the ciprofloxacin resistant isolates and the clones including isolates with 95% similarity correlated with the PFGE clones except that two further clones were identified using PFGE. We wanted identify related isolates and PFGE was therefore the typing method that we preferred for further studies. In addition AFLP was rather time consuming and not as well established in our laboratory.

## References:

1. Lin JJ, Kuo J, Ma J: **A PCR-based DNA fingerprinting technique: AFLP for molecular typing of bacteria.** *Nucleic acids research* 1996, **24**(18):3649-3650.
2. Zhao S, Mitchell SE, Meng J, Kresovich S, Doyle MP, Dean RE, Casa AM, Weller JW: **Genomic typing of Escherichia coli O157:H7 by semi-automated fluorescent AFLP analysis.** *Microbes and infection / Institut Pasteur* 2000, **2**(2):107-113.
3. Biosystems A: **AFLP™ Microbial fingerprinting protocol** In. Edited by Biosystems A: Applied Biosystems; 2002.
4. Hahm BK, Maldonado Y, Schreiber E, Bhunia AK, Nakatsu CH: **Subtyping of foodborne and environmental isolates of Escherichia coli by multiplex-PCR, rep-PCR, PFGE, ribotyping and AFLP.** *Journal of microbiological methods* 2003, **53**(3):387-399.
5. Iyoda S, Wada A, Weller J, Flood SJ, Schreiber E, Tucker B, Watanabe H: **Evaluation of AFLP, a high-resolution DNA fingerprinting method, as a tool for molecular subtyping of enterohemorrhagic Escherichia coli O157:H7 isolates.** *Microbiology and immunology* 1999, **43**(8):803-806.
6. Lassen J: **Rapid identification of gram-negative rods using a three-tube method combined with a dichotomic key.** *Acta pathologica et microbiologica Scandinavica Supplement* 1975, **83**(6):525-533.